

6. Wiring Diagram

A: POWER SUPPLY ROUTING

1. LHD MODEL

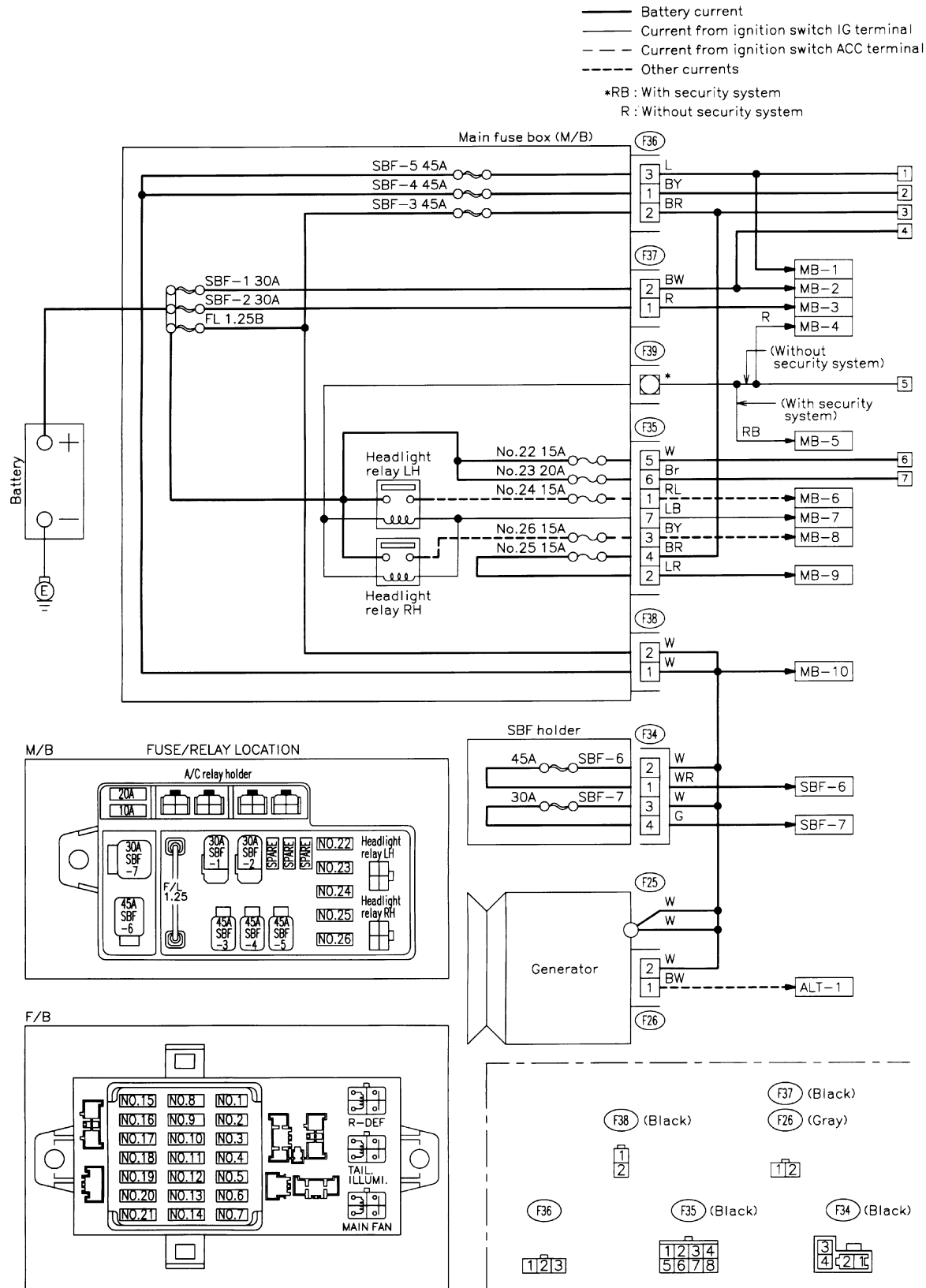

BU01-03A

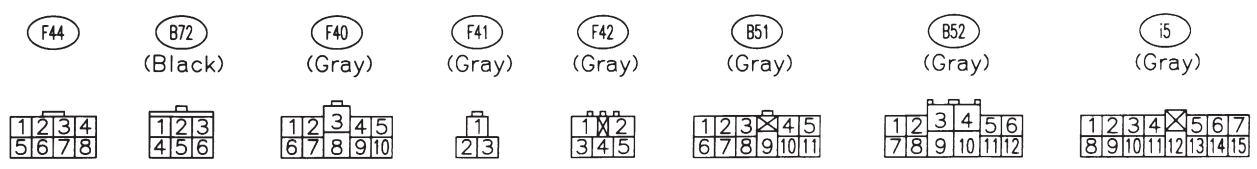
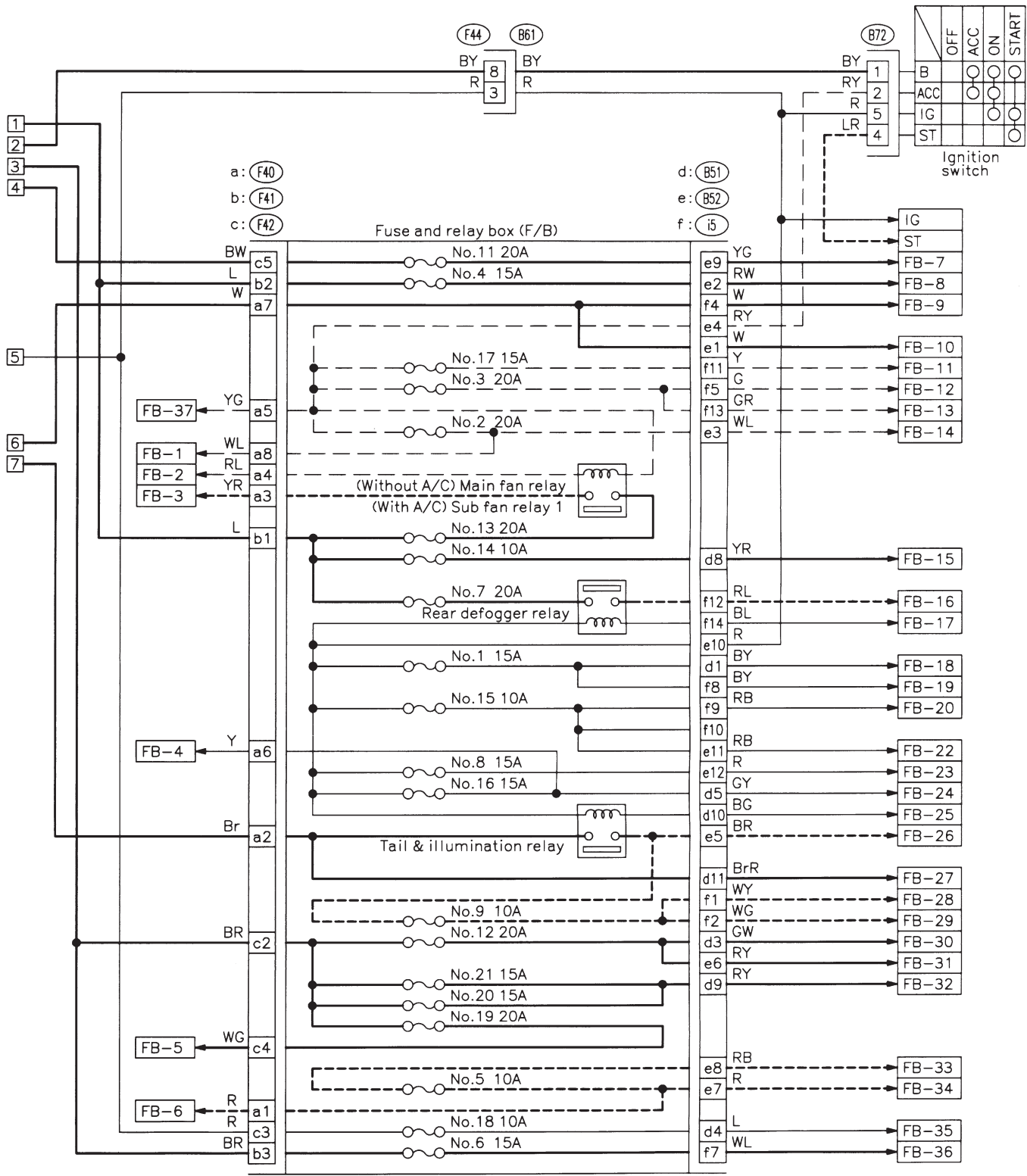

6. Wiring Diagram

No.	Load
MB-1	Fuse holder (Rear power supply & seat heater)
MB-2	Power window circuit breaker
MB-3	Engine control module Fuel pump relay Main relay OBD-II service connector
MB-4	A/C relay holder
MB-5	Headlight alarm relay (with security)
MB-6	Headlight LH
MB-7	Daytime running light control module Diode (Lighting) Diode (Security) Lighting switch
MB-8	Combination meter Front fog light switch Headlight RH Front fog light relay
MB-9	Door lock timer Headlight alarm relay Interrupt relay Radio Security control module Security indicator light Spot light Room light Step light Combination meter Luggage room light Trailer connector Trunk room light
MB-10	A/C relay holder
SBF-6	ABS relay box TCS motor relay
SBF-7	TCS valve relay
ALT-1	Combination meter Daytime running light control module Diode (TCS)
IG	Headlight alarm relay
ST	Cruise control module Engine control module Inhibitor switch (AT) Interrupt relay Starter interlock relay (MT)
FB-1	Front washer motor Rear washer motor
FB-2	Engine control module Main fan relay 1
FB-3	Sub fan relay 2 Sub fan motor
FB-4	Engine control module Fuel pump relay Ignition coil Transmission control module
FB-5	ABS relay box
FB-6	Side marker light LH Side marker light RH

No.	Load
FB-7	Door lock timer
FB-8	Wiper deicer relay
FB-9	Hazard switch
FB-10	AT shift lock control module Key warning switch Power antenna
FB-11	Radio
FB-12	Front accessory power supply
FB-13	Mirror heater Rear power supply relay Remote control rearview mirror switch Security control module Vanity mirror illumination light
FB-14	AT shift lock control module Combination switch Front wiper motor Rear wiper motor Rear wiper relay
FB-15	ABS/TCS control module Transmission control module
FB-16	Rear defogger Rear defogger condenser Rear defogger switch
FB-17	Rear defogger timer
FB-18	AT shift lock control module Back-up light switch (MT) Inhibitor switch (AT)
FB-19	Hazard switch
FB-20	A/C switch Combination meter Mode control panel Rear defogger timer TCS off switch
FB-22	Blower motor relay Check connector Daytime running light control module Daytime running light relay FRESH/RECIRC actuator Hi-beam relay Power window and sunroof relay Seat belt timer Wiper deicer relay Wiper deicer timer
FB-23	Airbag control module
FB-24	Airbag control module
FB-25	Lighting switch
FB-26	Parking switch
FB-27	Parking switch
FB-28	Illumination light
FB-29	Illumination light
FB-30	Pedal stroke switch Stop light switch Stop & brake switch
FB-31	Horn relay
FB-32	Blower motor relay
FB-33	Parking switch

No.	Load
FB-34	License plate light Rear combination light LH Rear combination light RH Rear finisher light LH Rear finisher light RH
FB-35	ABS control module ABS/TCS control module TCS valve relay Cruise control main switch Cruise control module
FB-36	Front fog light relay
FB-37	Main fan relay 1

2. RHD MODEL

- Battery current
- Current from ignition switch IG terminal
- - - Current from ignition switch ACC terminal
- Other currents

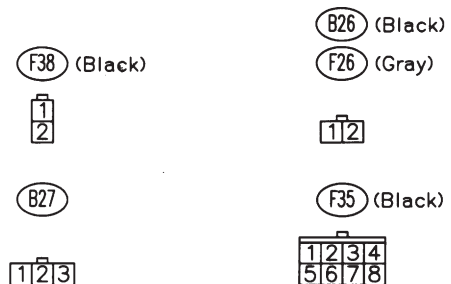
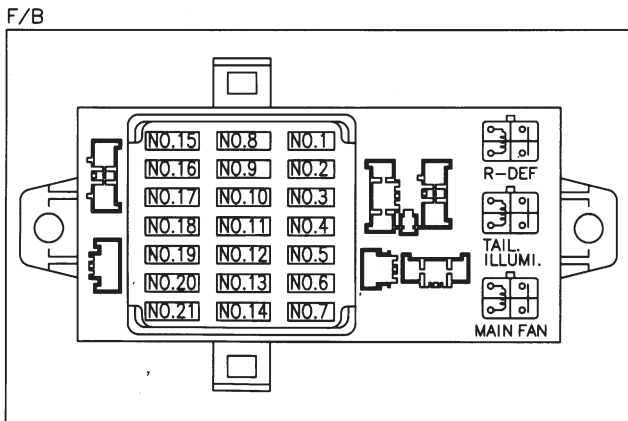
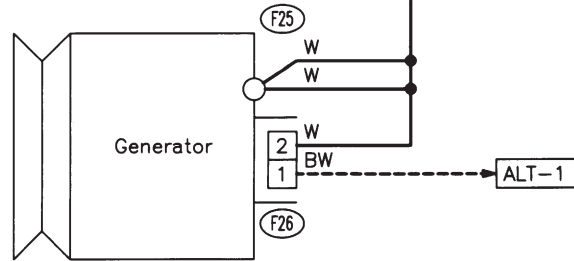
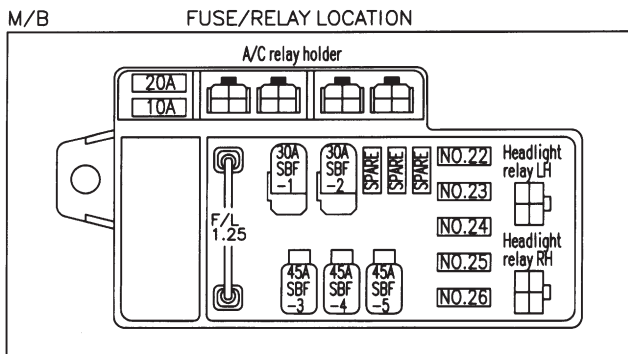
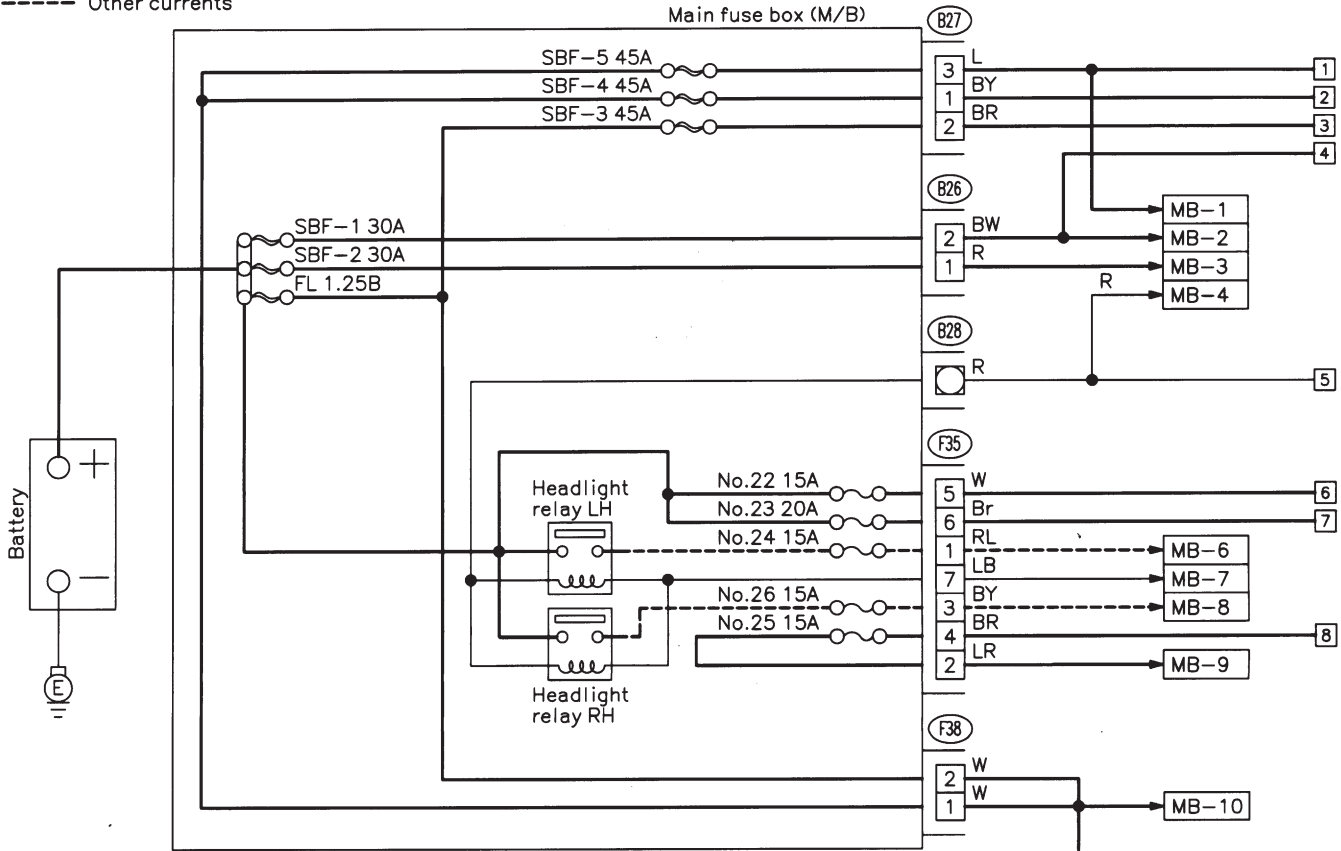

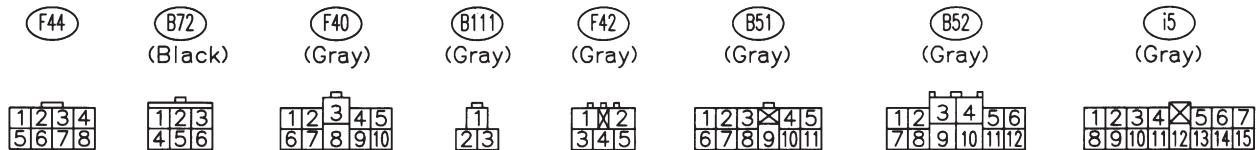
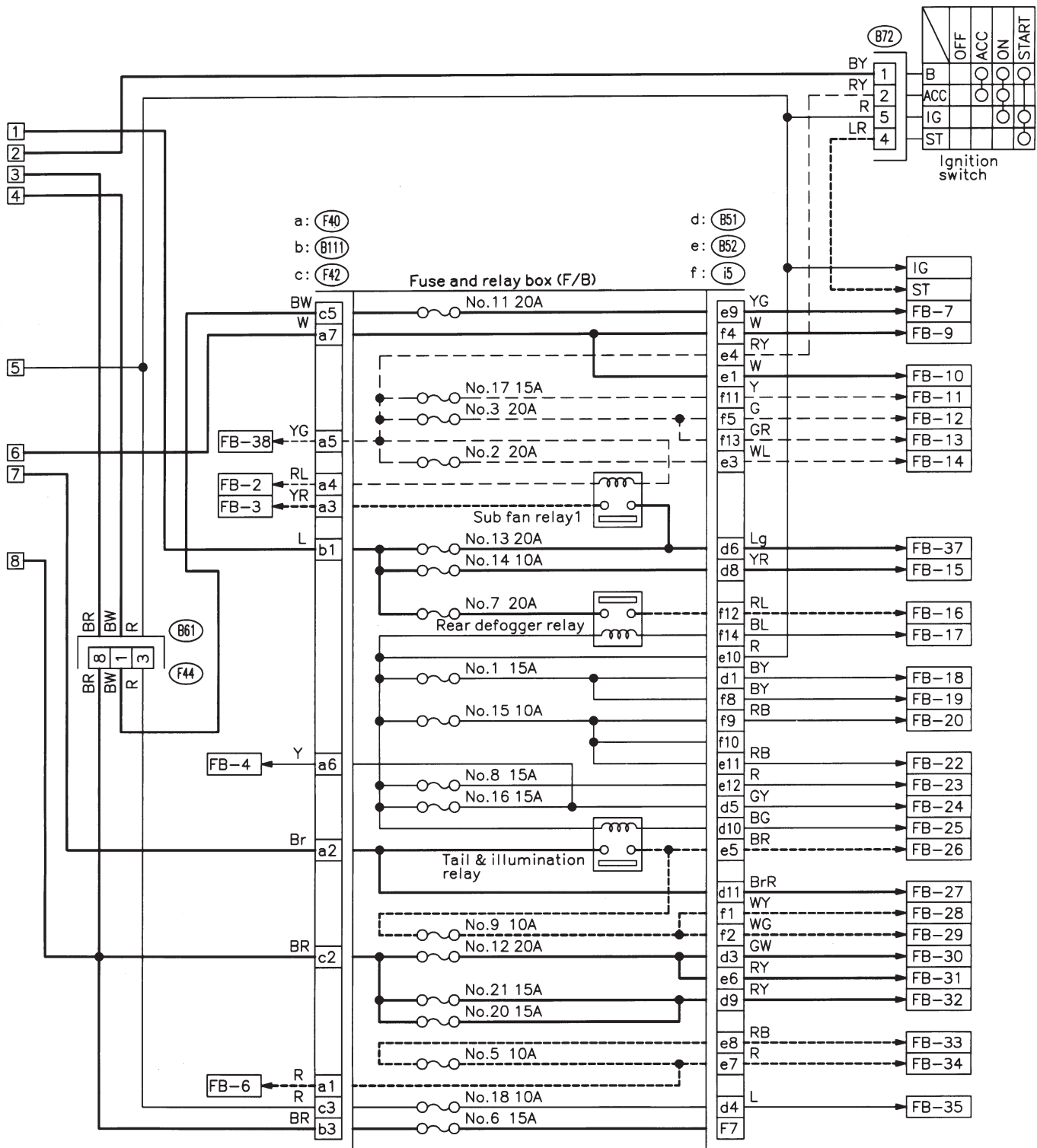

6. Wiring Diagram

No.	Load
MB-2	Power window circuit breaker
MB-3	Engine control module Fuel pump relay Main relay OBD-II service connector
MB-4	A/C relay holder
MB-6	Headlight LH
MB-7	Diode (Lighting) Lighting switch
MB-8	Combination meter Headlight RH
MB-9	Combination meter Door lock timer Luggage room light Radio Room light
MB-10	A/C relay holder
ALT-1	Combination meter
IG	A/C relay holder
ST	Cruise control module Engine control module Inhibitor switch
FB-2	Engine control module Main fan relay 1
FB-3	Sub fan motor Sub fan relay-2
FB-4	Engine control module Fuel pump relay Ignition coil Transmission control module
FB-6	Side marker light LH Side marker light RH
FB-7	Door lock timer
FB-9	Hazard switch
FB-10	AT shift lock control module Key warning switch Power antenna
FB-11	Radio
FB-12	Cigarette lighter
FB-13	Remote control rearview mirror switch
FB-14	AT shift lock control module Combination switch Front washer motor Front wiper motor Rear washer motor Rear wiper motor Rear wiper relay
FB-15	Transmission control module
FB-16	Rear defogger Rear defogger condenser Rear defogger switch
FB-17	Rear defogger timer
FB-18	AT shift lock control module Inhibitor switch
FB-19	Hazard switch

No.	Load
FB-20	Combination meter Mode control panel Rear defogger timer
FB-22	Blower motor relay Check connector FRESH/RECIRC actuator Mode actuator Power window relay Seat belt timer
FB-23	Airbag control module
FB-24	Airbag control module
FB-25	Lighting switch
FB-26	Parking switch
FB-27	Parking switch
FB-28	Illumination light
FB-29	Illumination light
FB-30	Stop light switch Stop & brake switch
FB-31	Horn relay
FB-32	Blower motor relay
FB-33	Parking switch
FB-34	License plate light LH License plate light RH Rear combination light LH Rear combination light RH Rear finisher light LH Rear finisher light RH
FB-35	Cruise control main switch Cruise control module
FB-38	Main fan relay 1

MEMO:

B: GROUND DISTRIBUTION

1. LHD MODEL

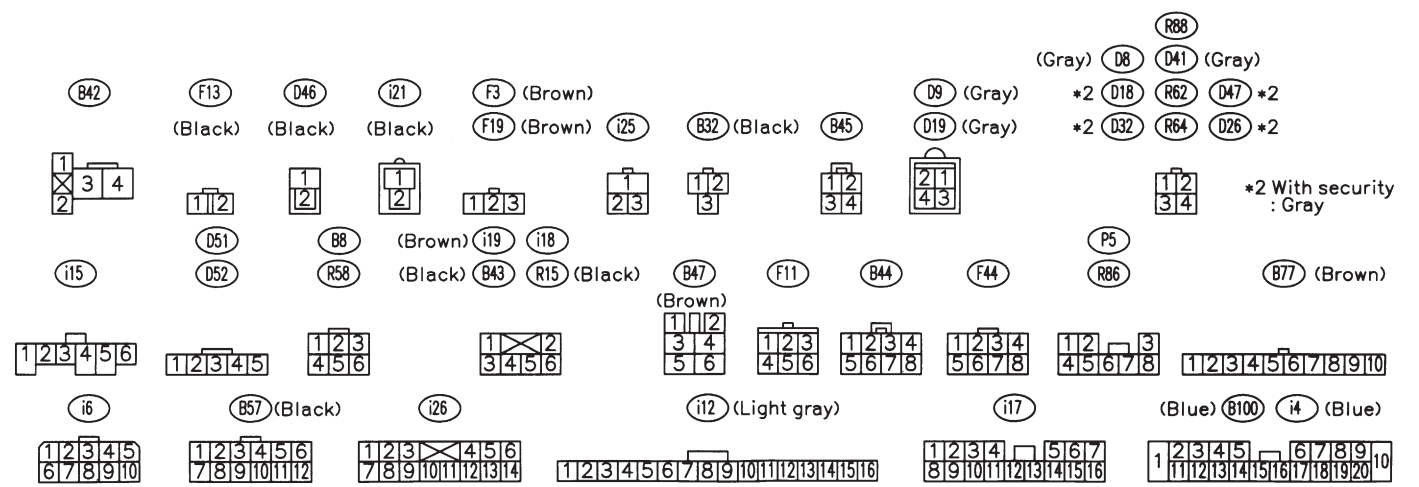
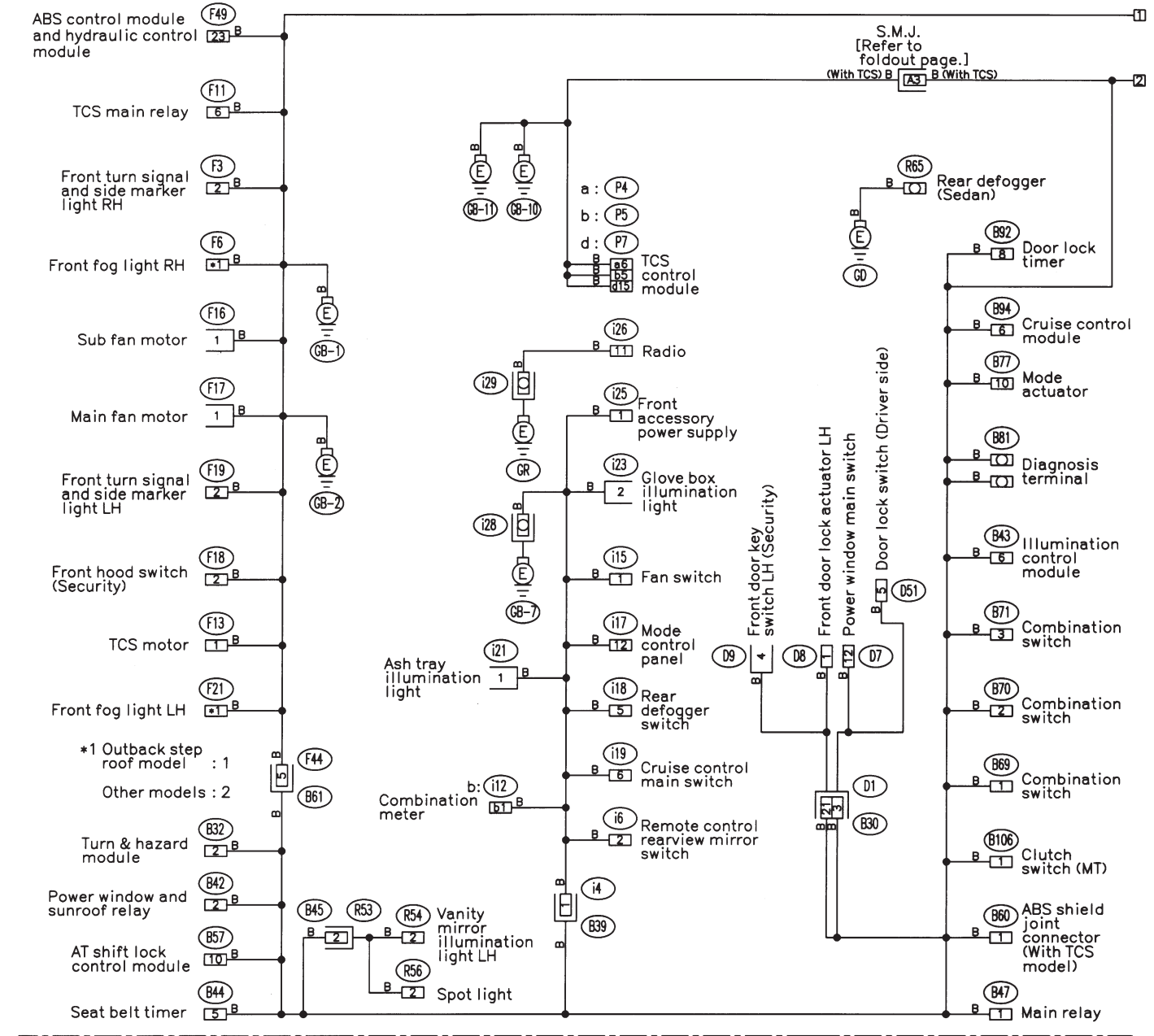

MEMO:

2. RHD MODEL

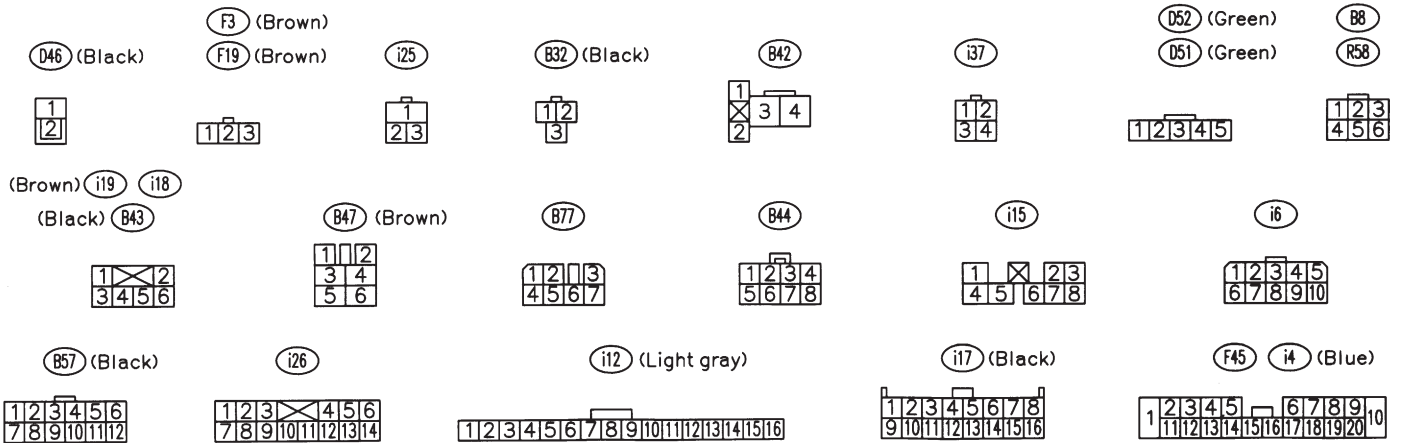
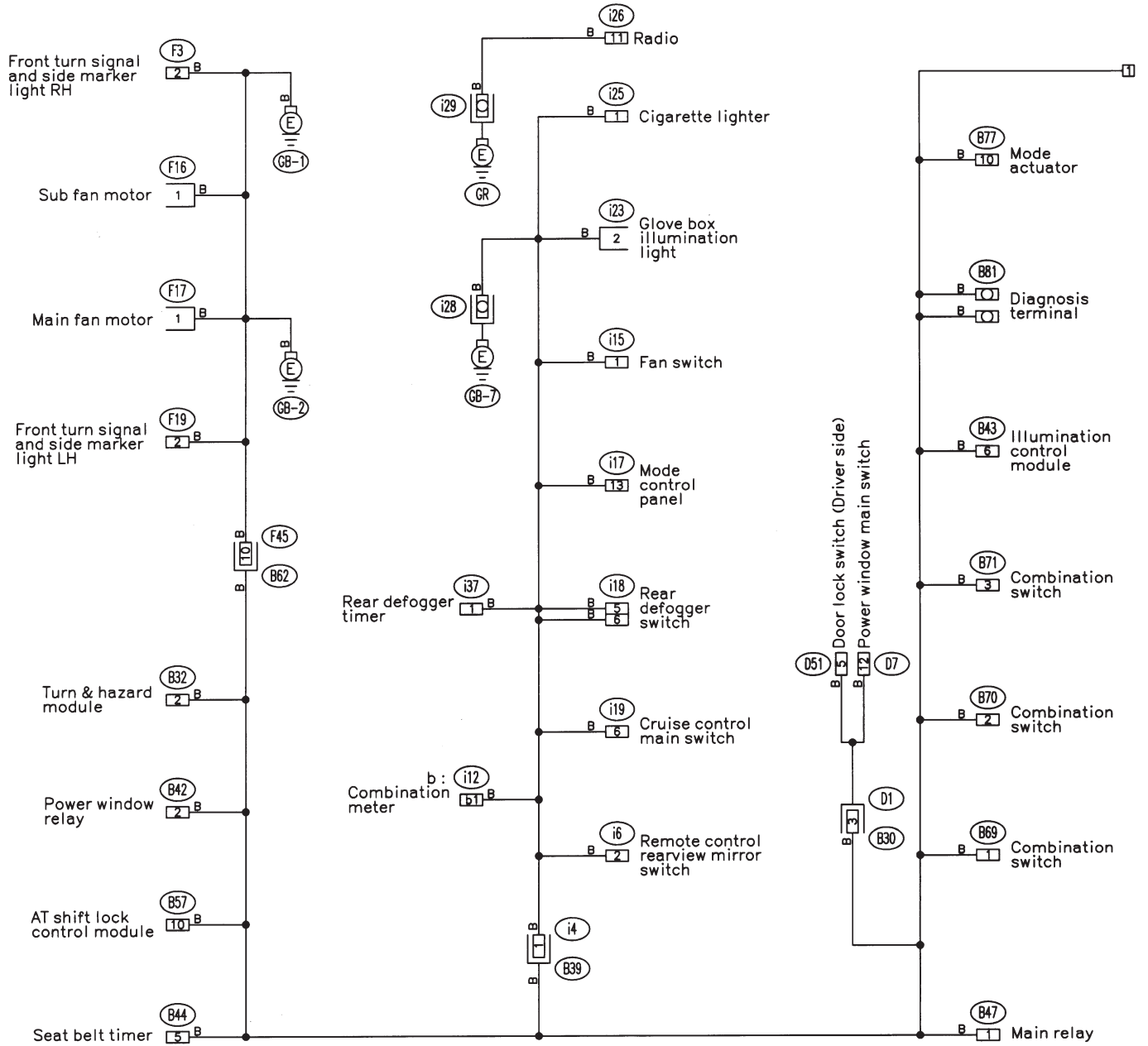

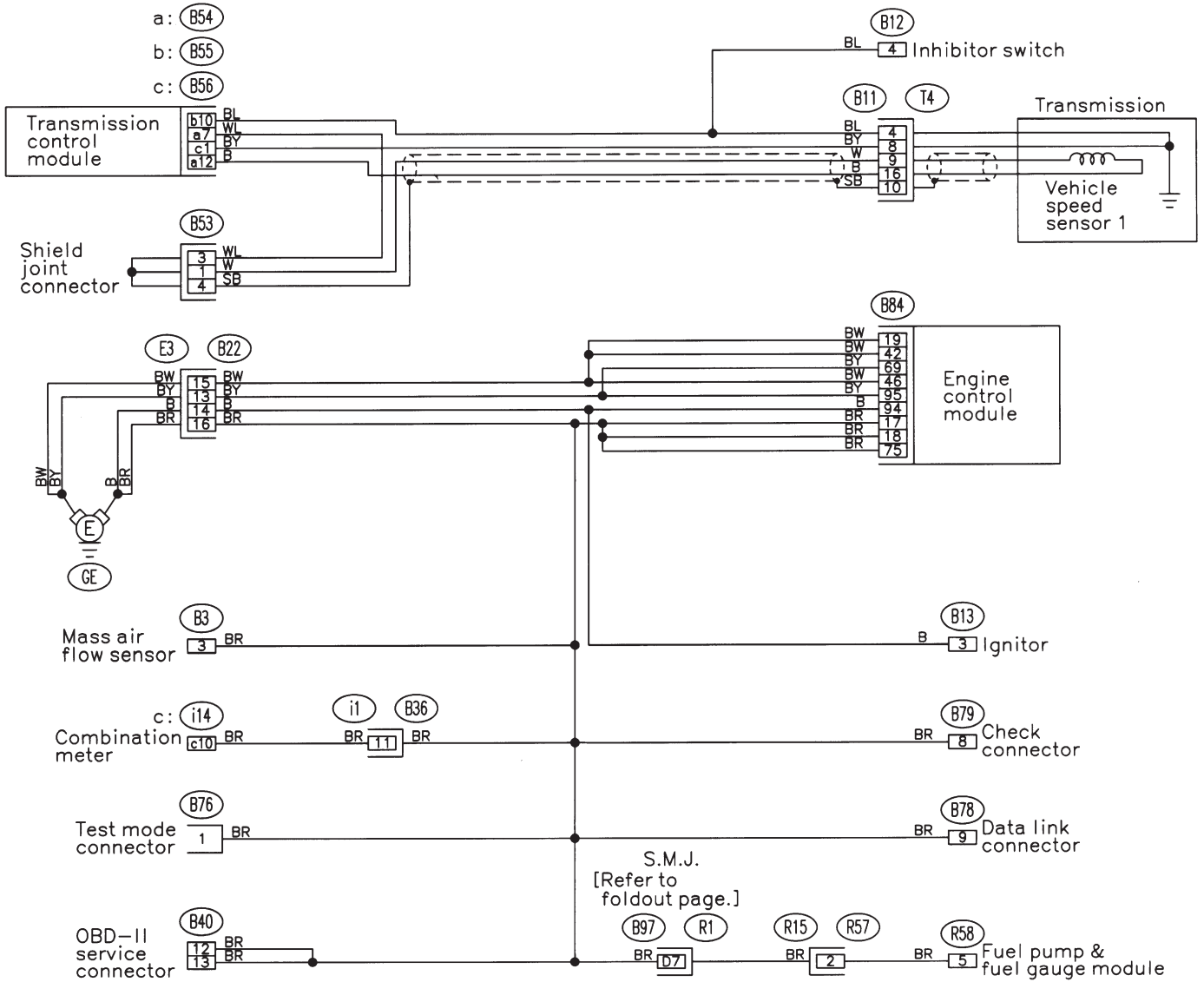

(B76) (Green) (B53) (B3) (Gray) (B13) (Gray) (R58) (R57) (B78) (Yellow) (B54) (Black)

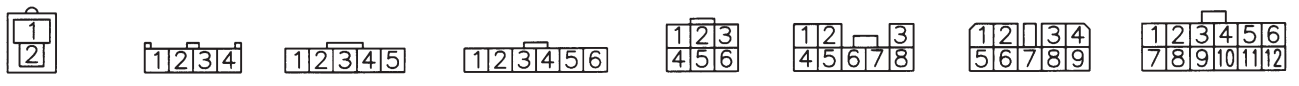

(B12) (Gray) (i14) (B79) (Gray) (B11) (Gray) (B22) (Light gray) (B55) (Black) (B40) (Gray)

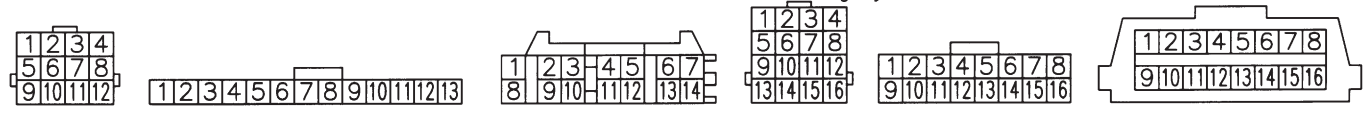

(B56) (Black) (i1) (Black) (B84) (Light blue)

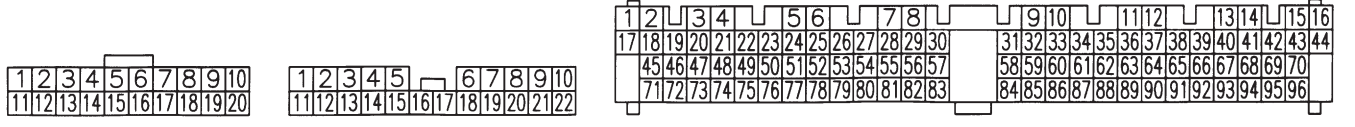

C: AIRBAG SYSTEM

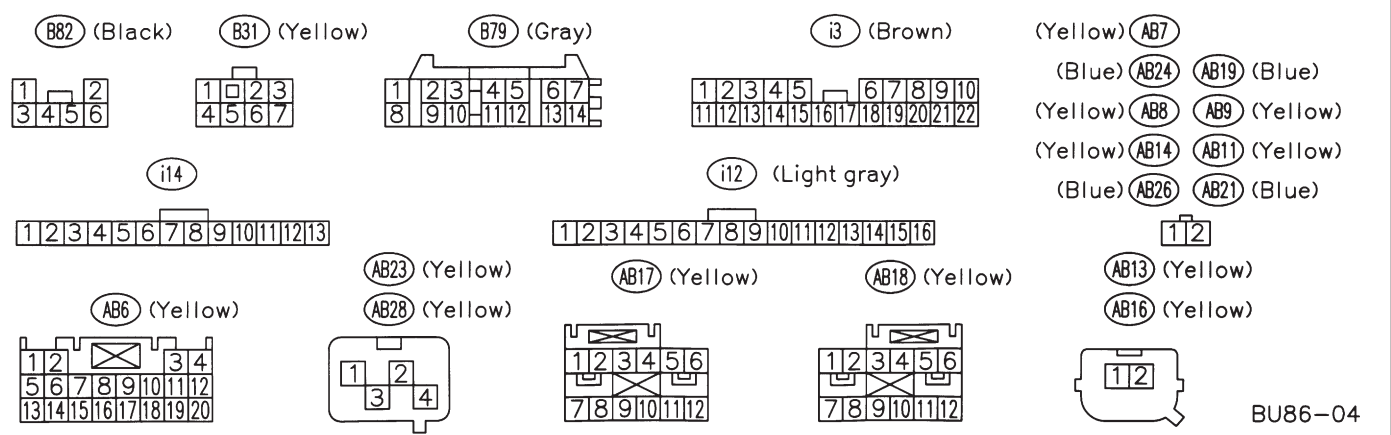
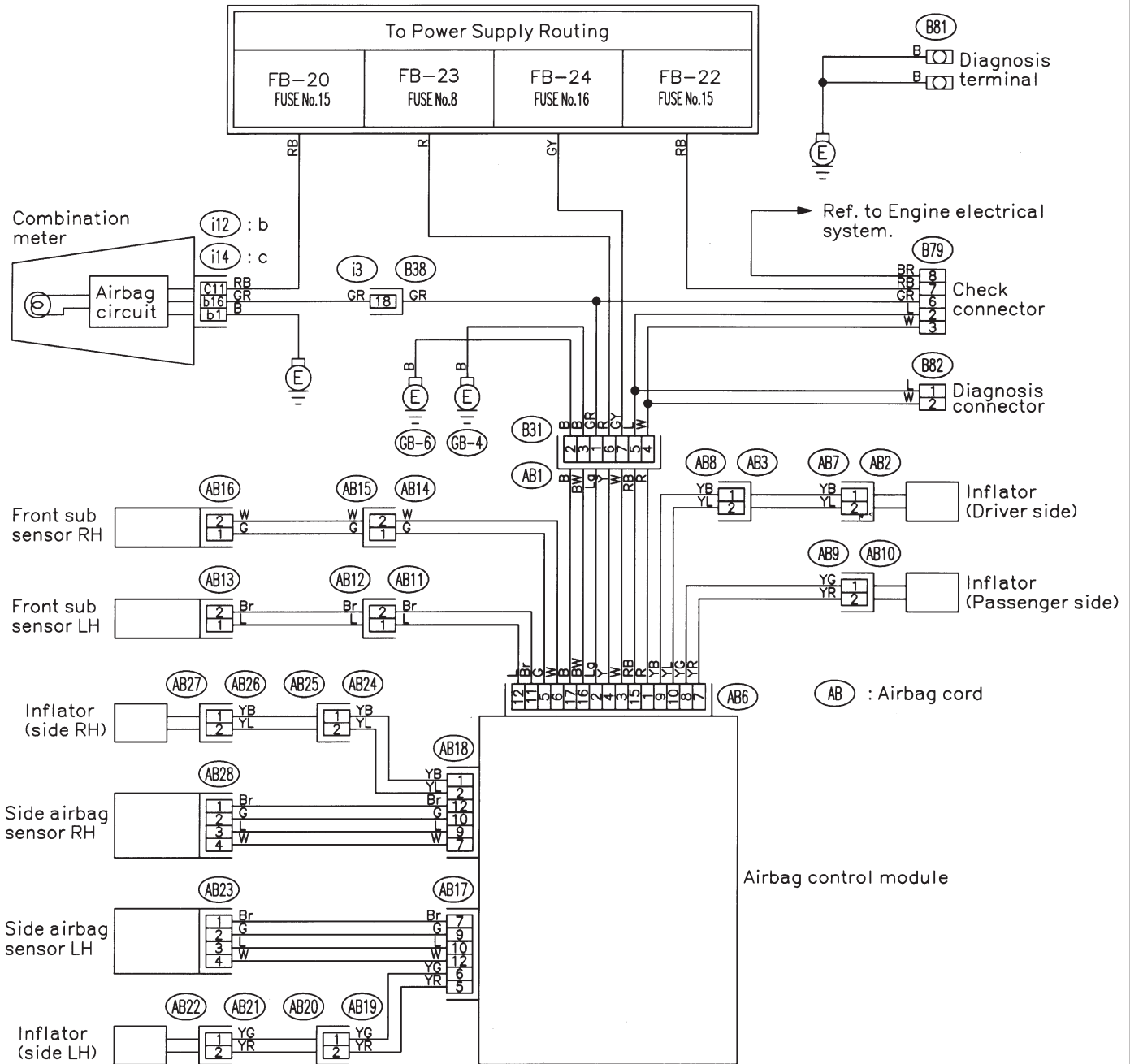

D: AIR CONDITIONING SYSTEM

1. LHD MODEL

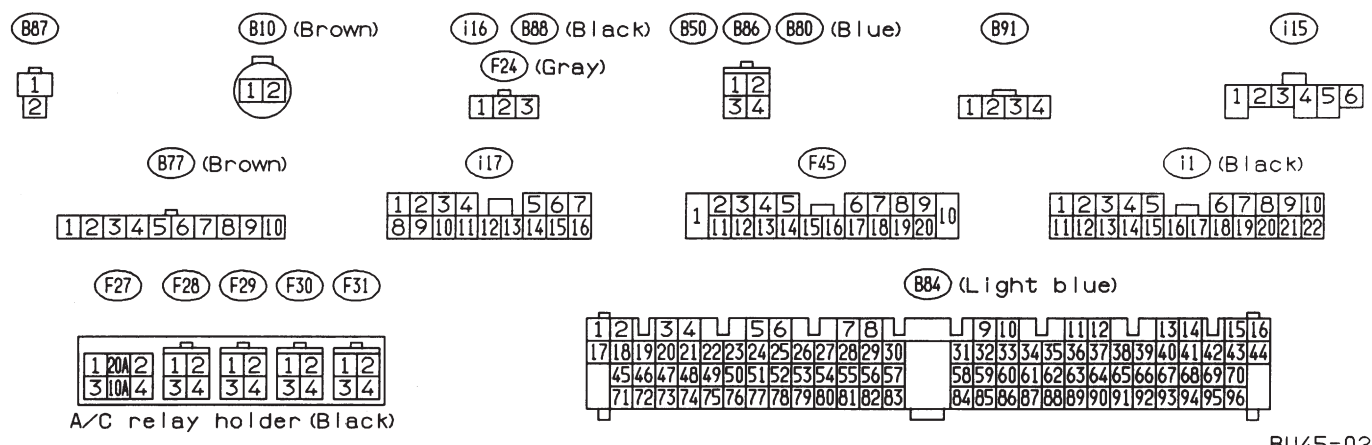
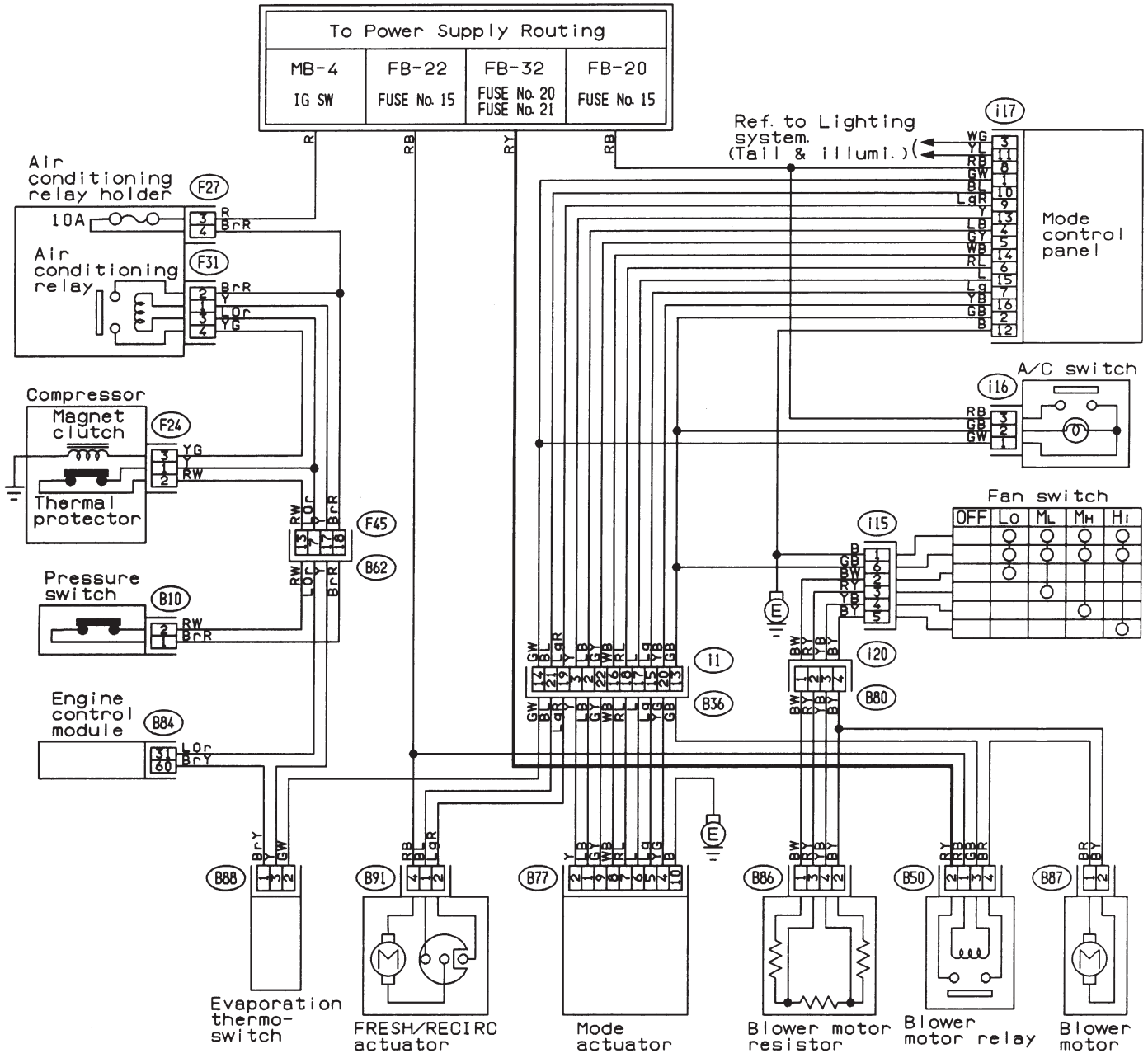

2. RHD MODEL

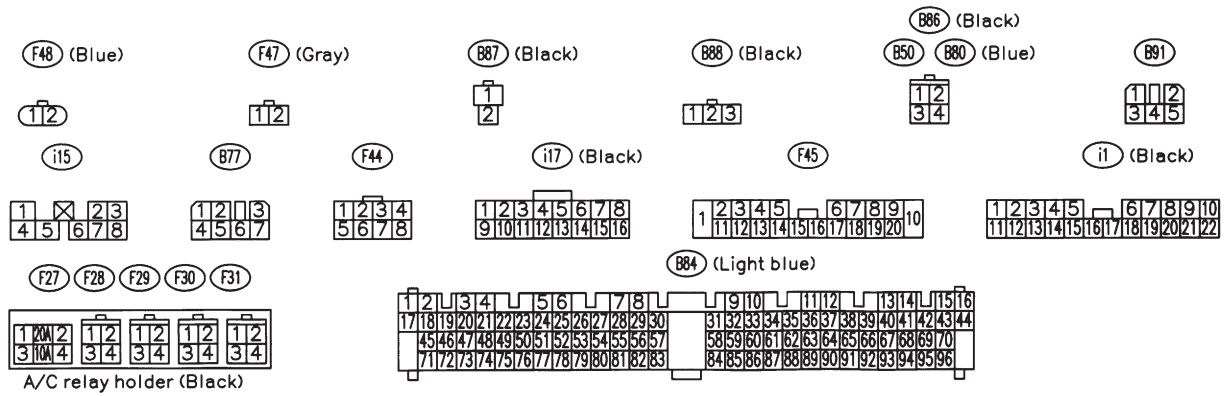
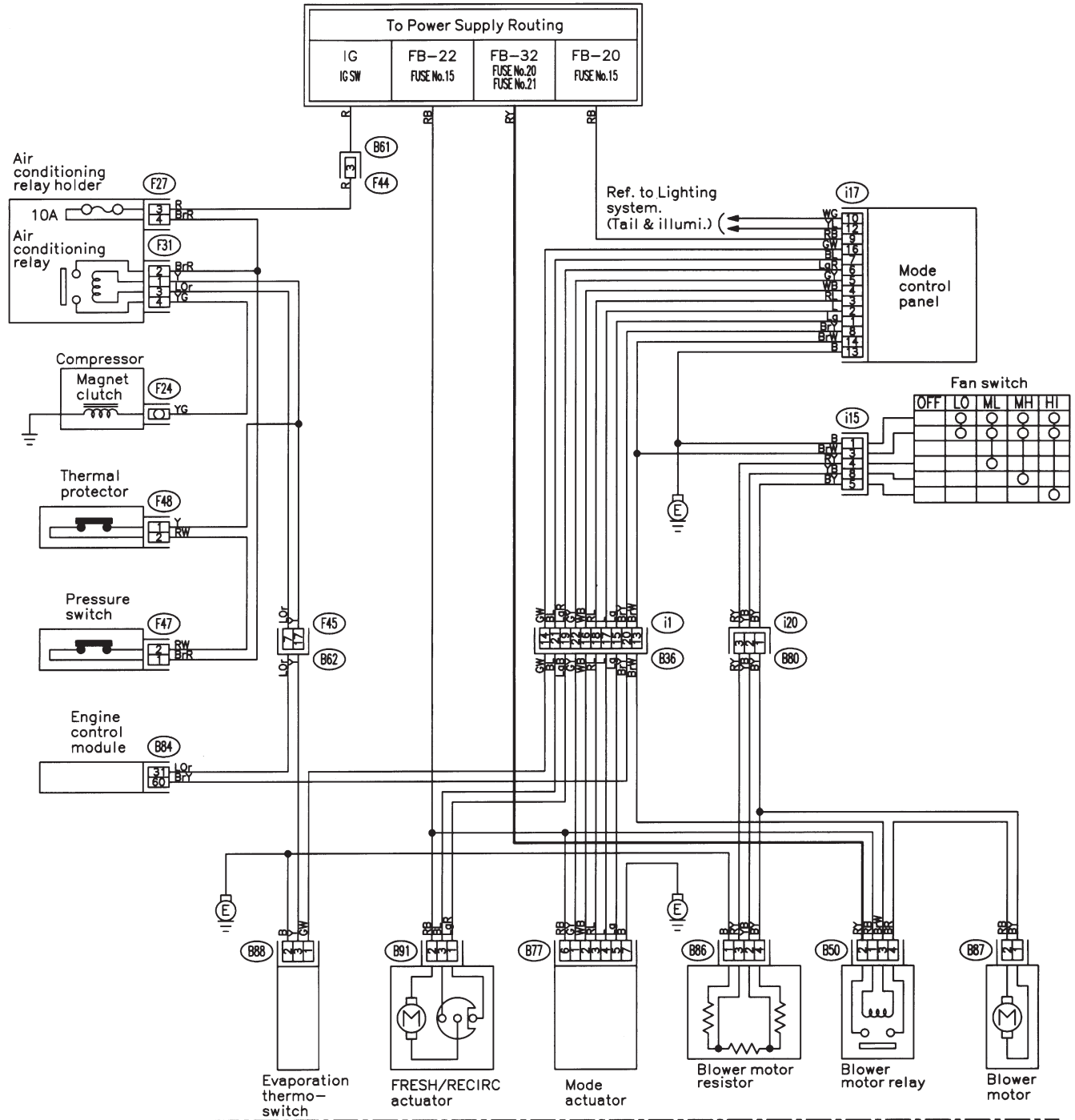

E: ANTI-LOCK BRAKE SYSTEM

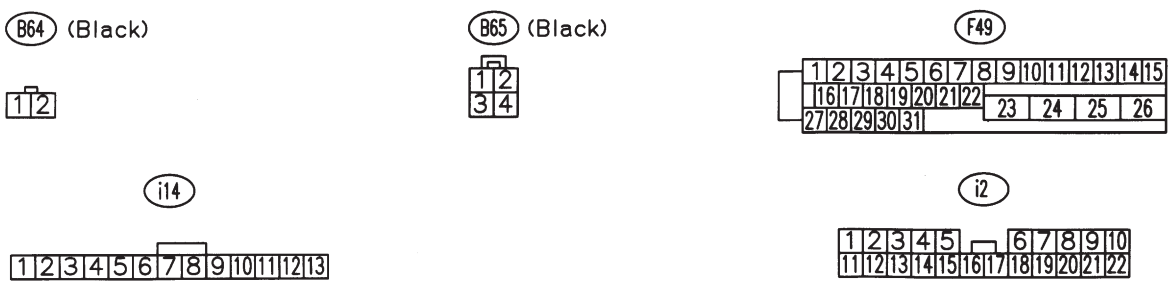
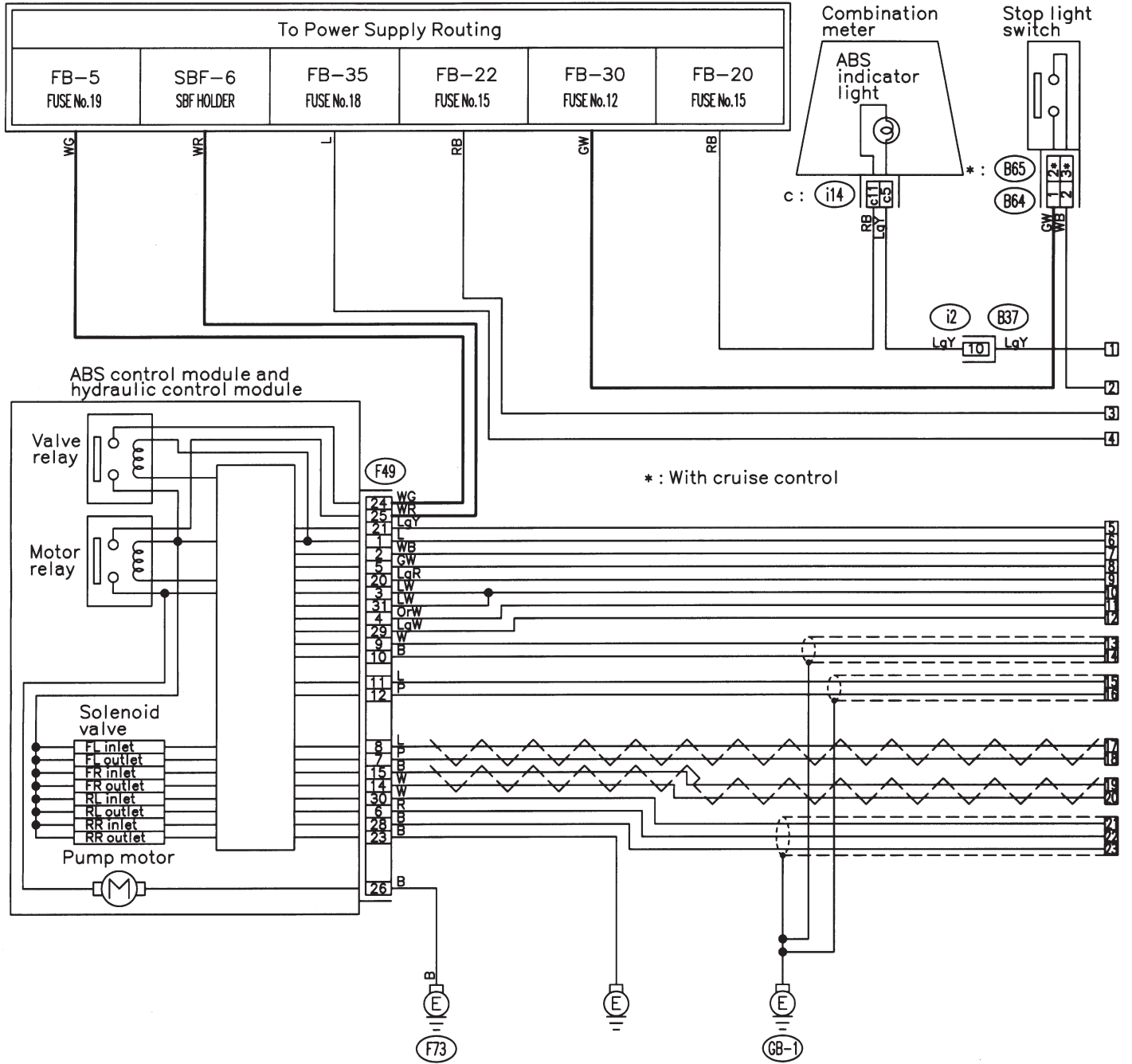

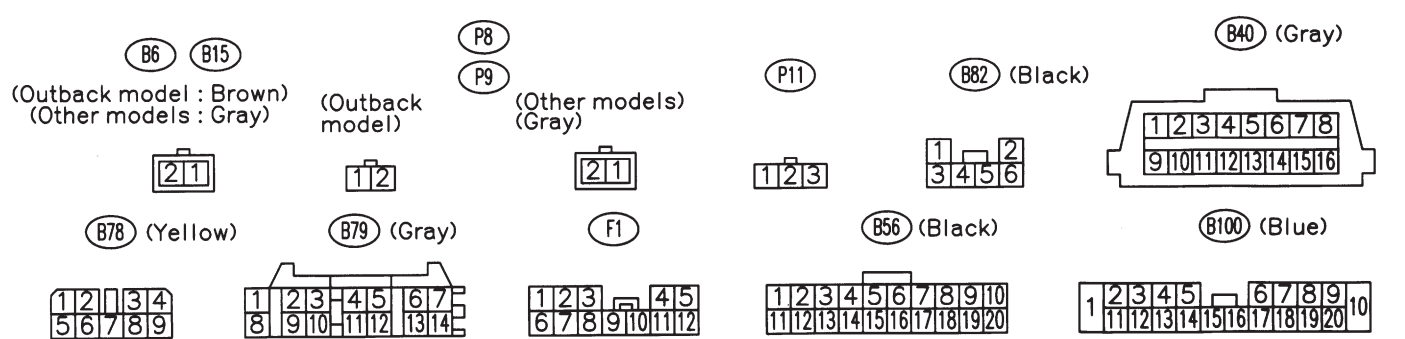
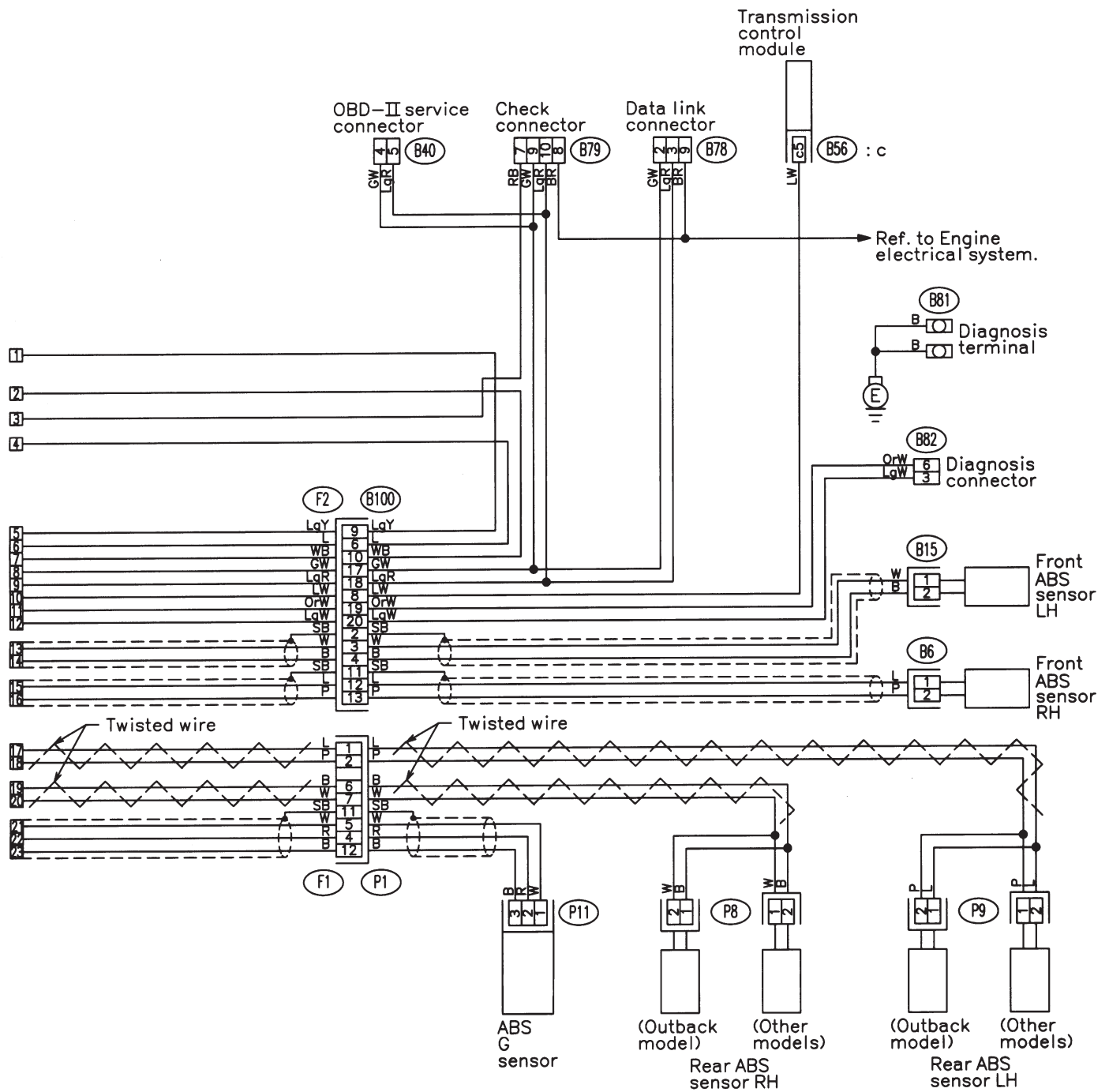

BU82-05B

F: A/T CONTROL SYSTEM

1. LHD MODEL

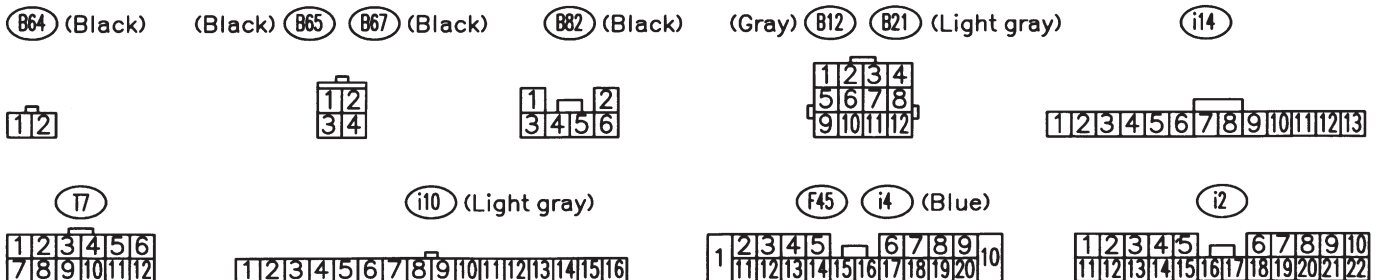
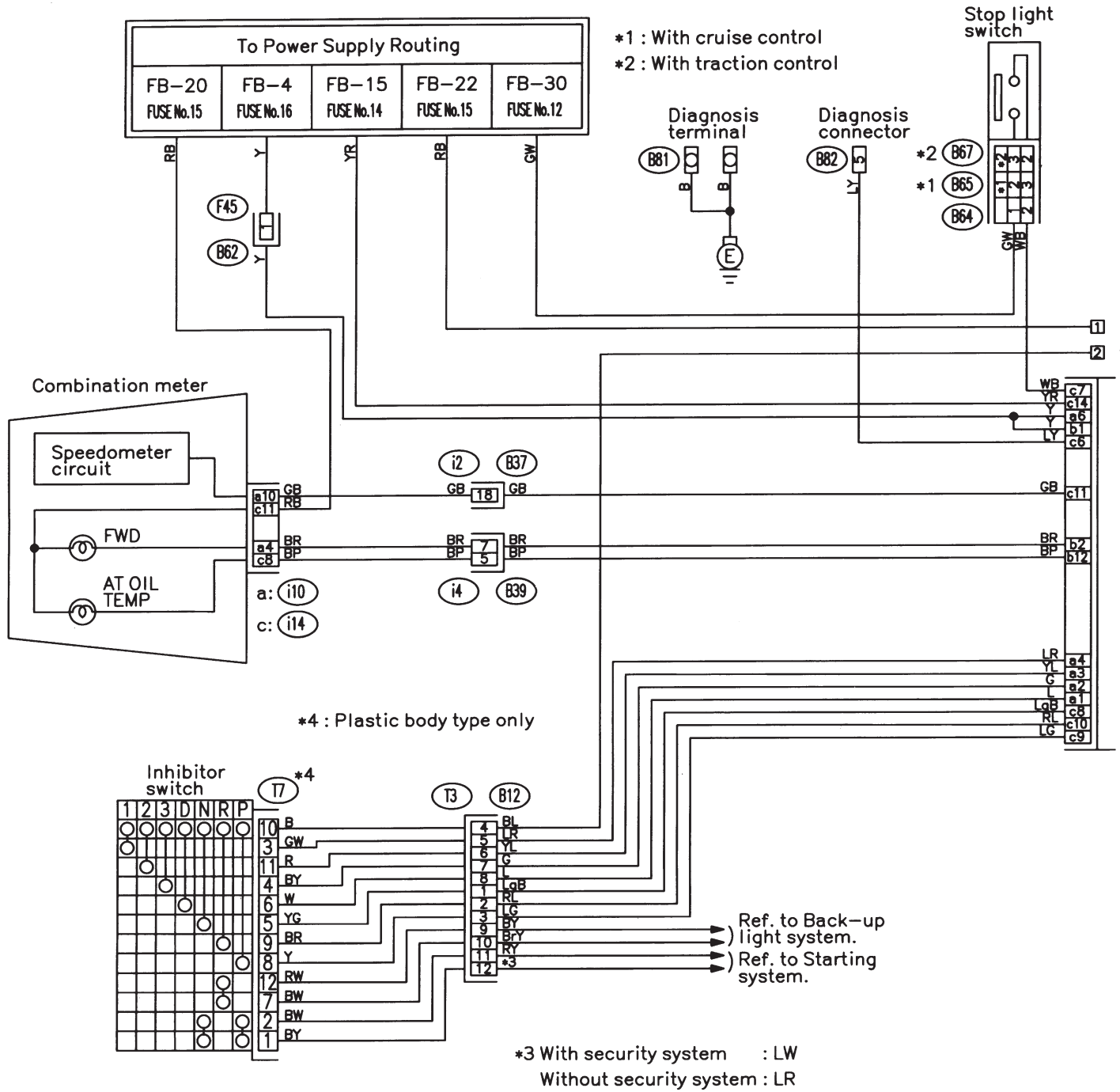

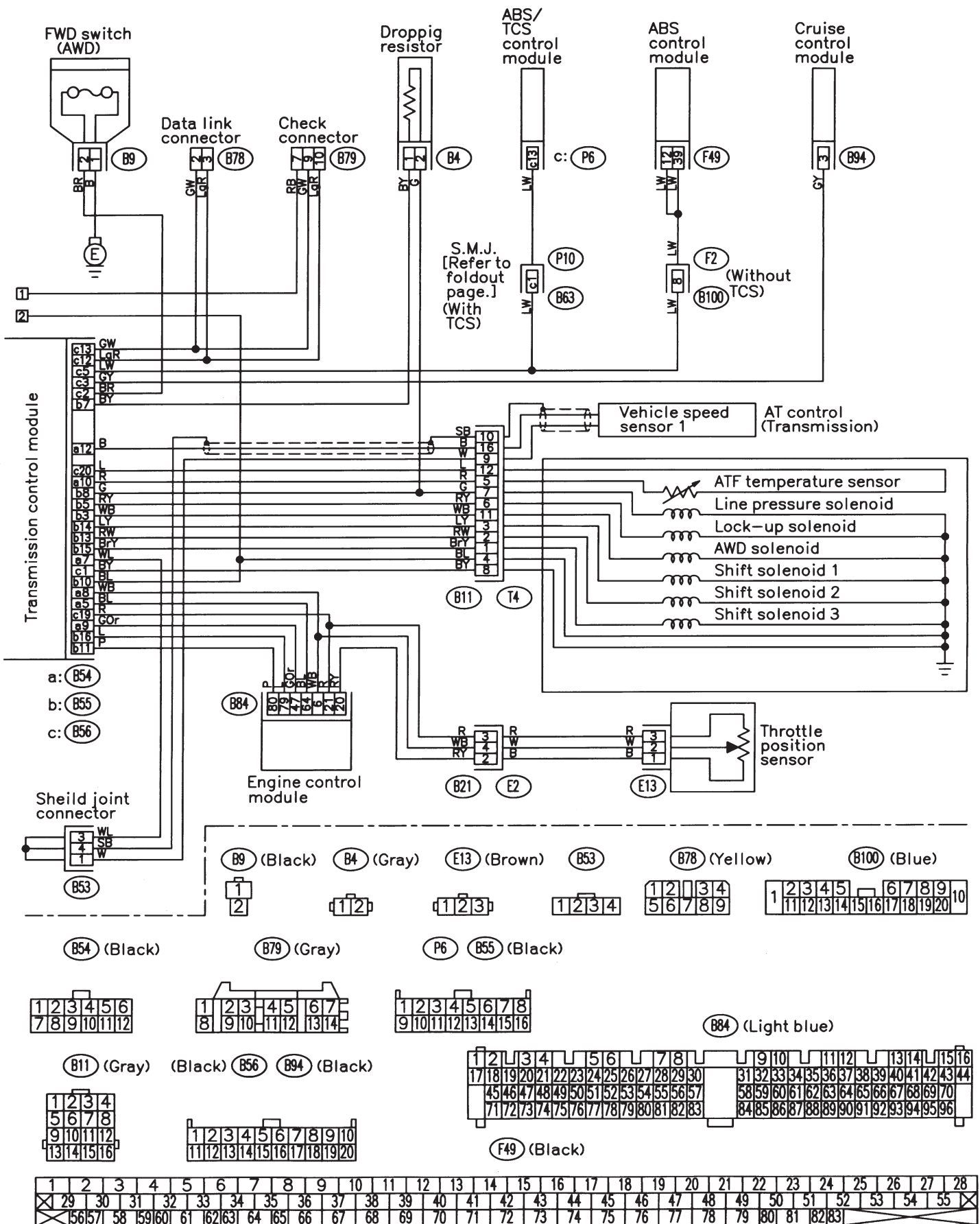

2. RHD MODEL

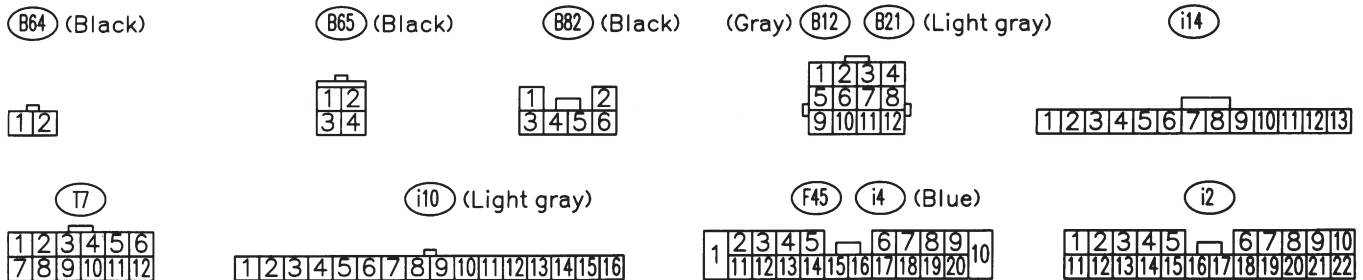
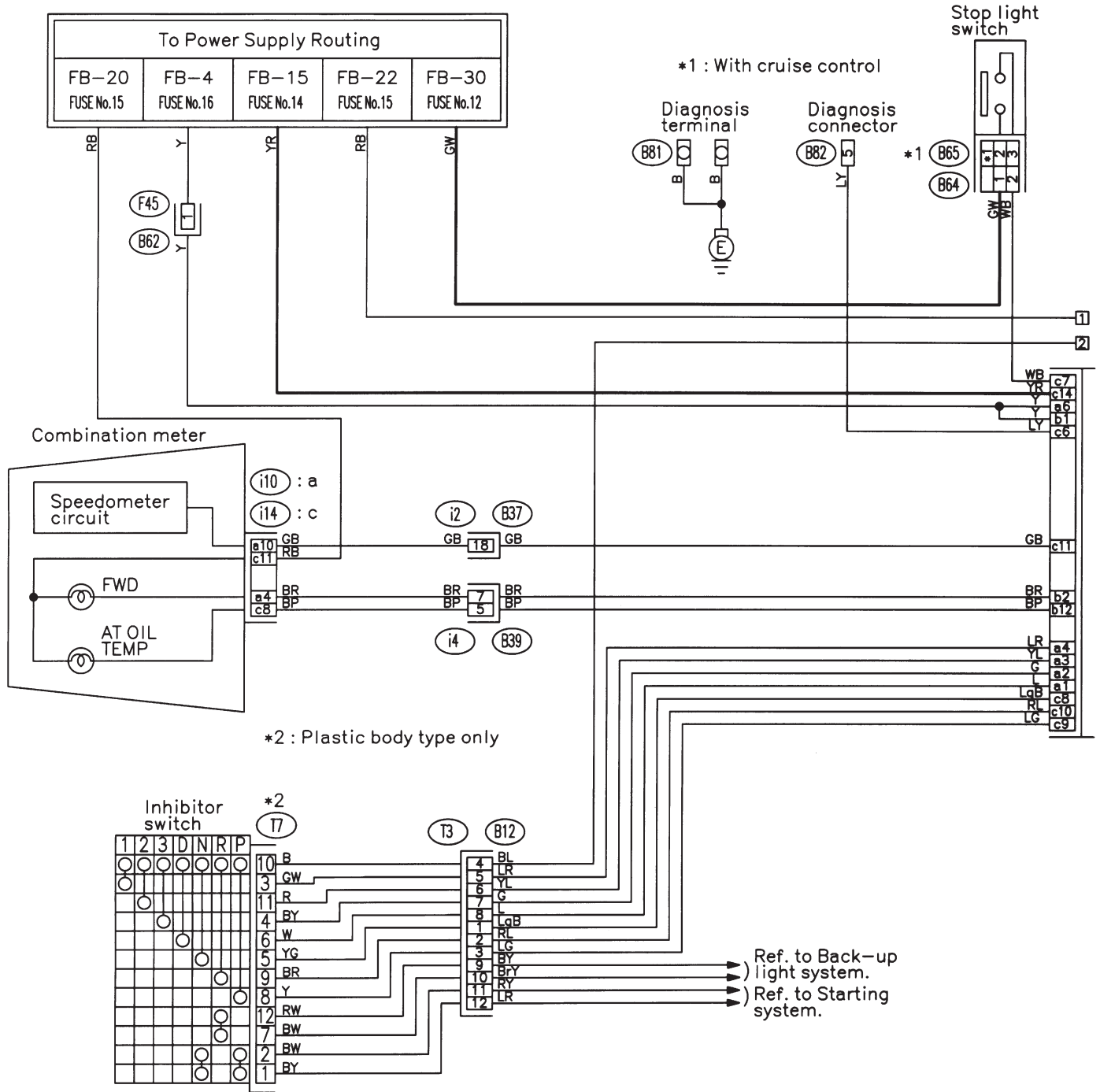

G: A/T SHIFT LOCK SYSTEM

1. LHD MODEL

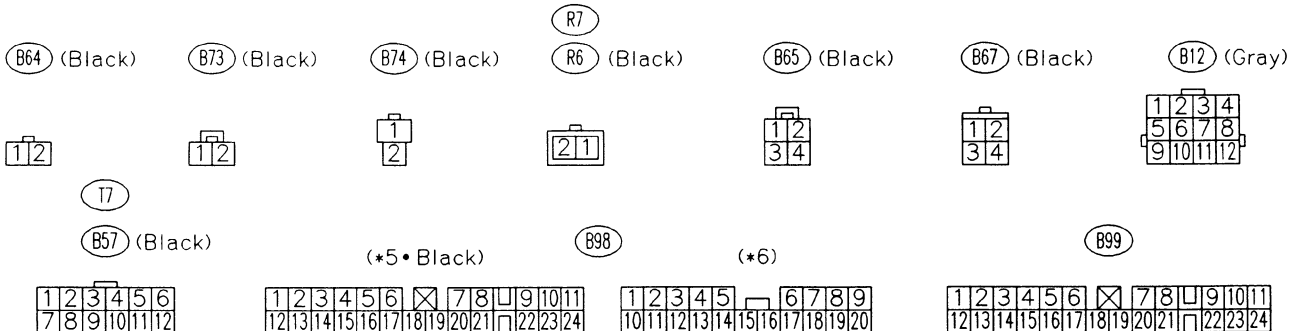
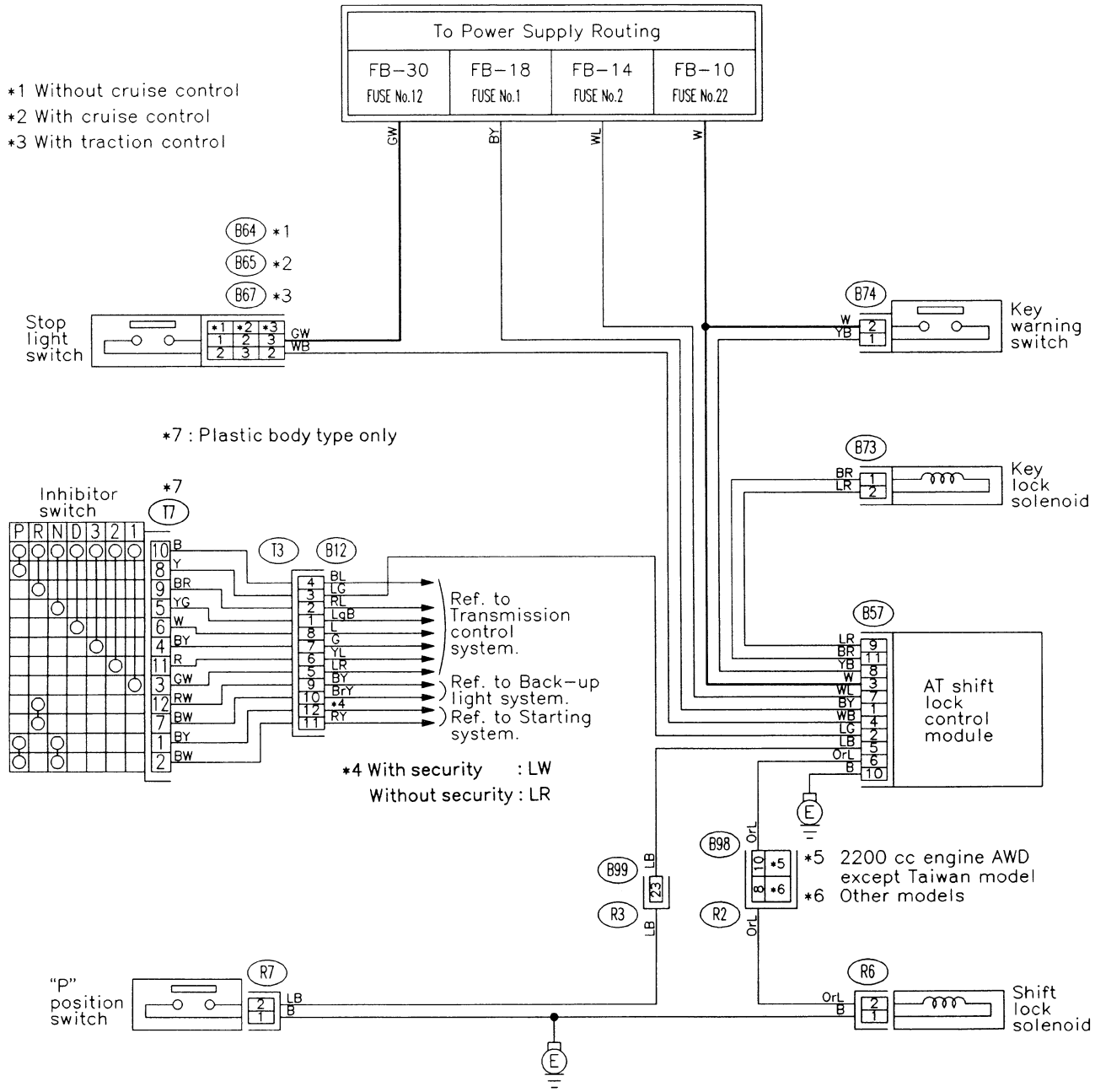

2. RHD MODEL

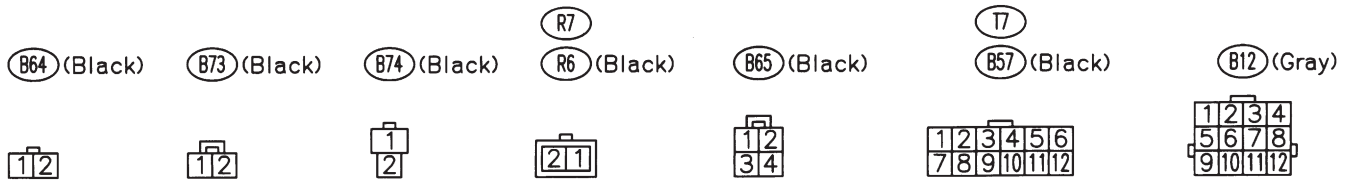
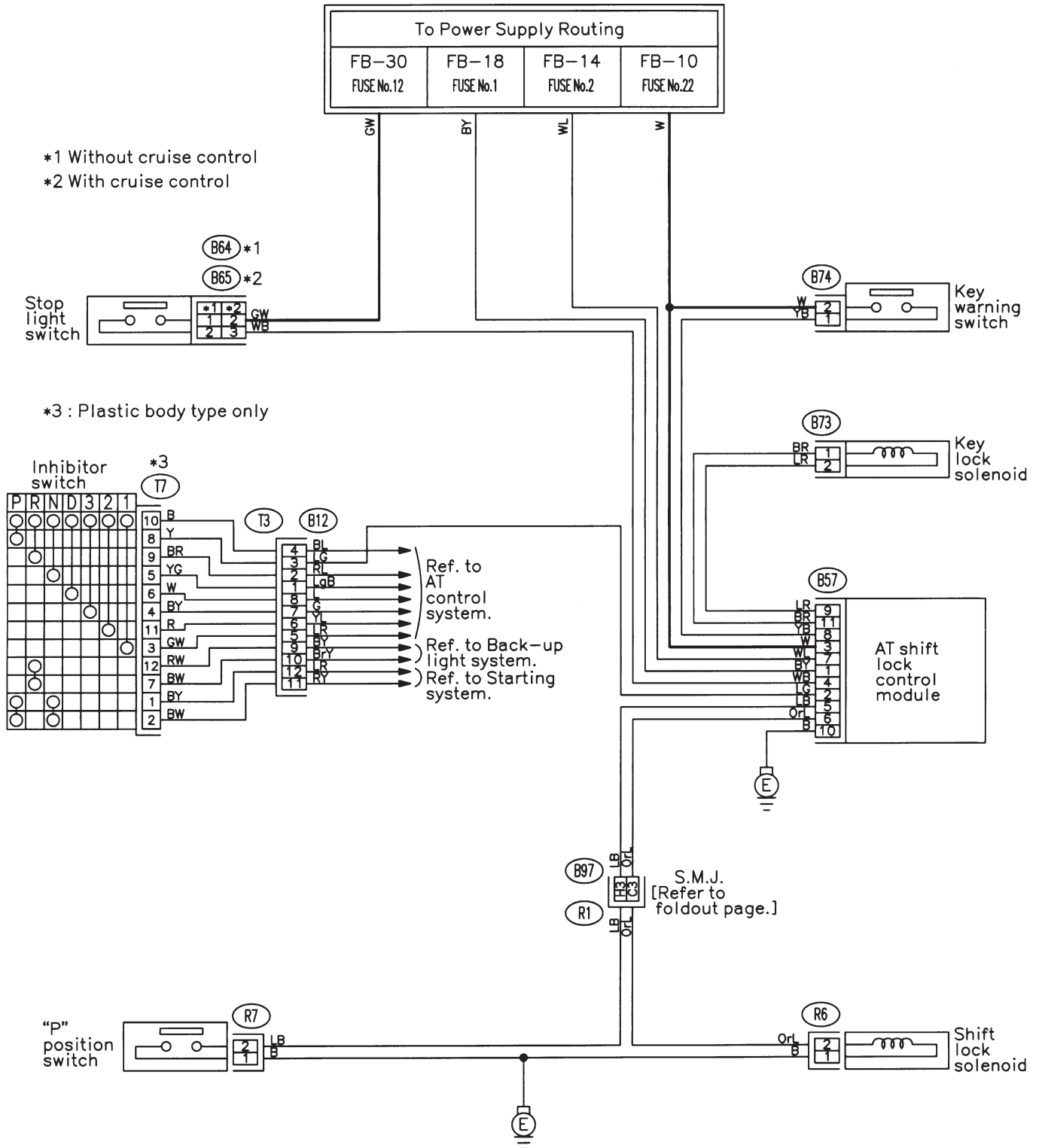

H: AUDIO SYSTEM

1. LHD MODEL

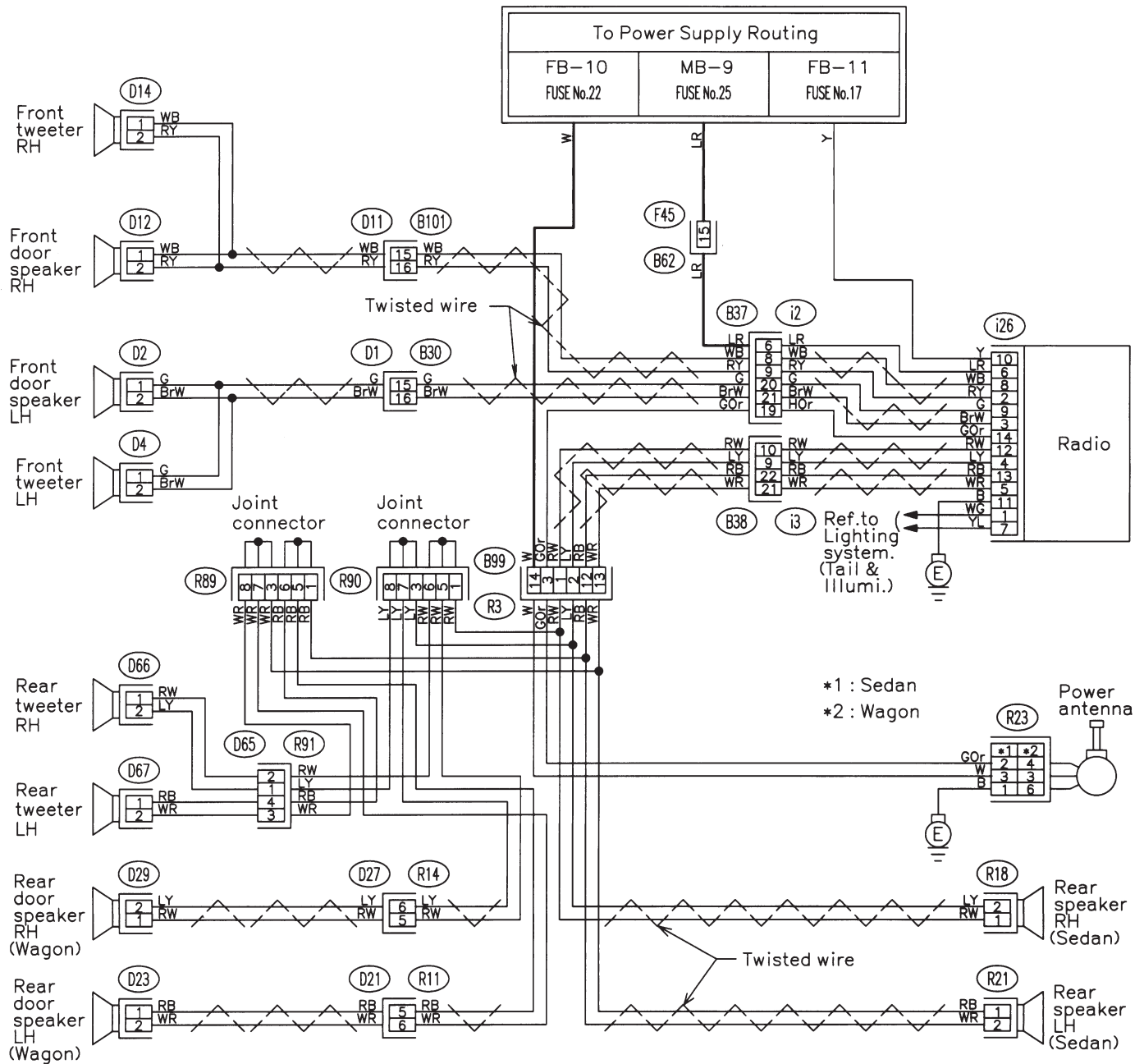

*1: Sedan
*2: Wagon

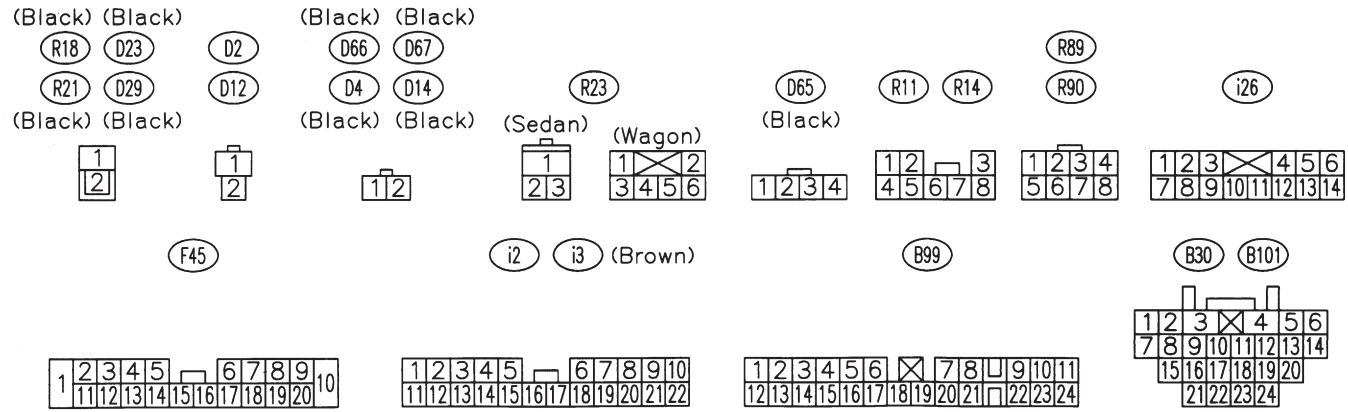

2. RHD MODEL

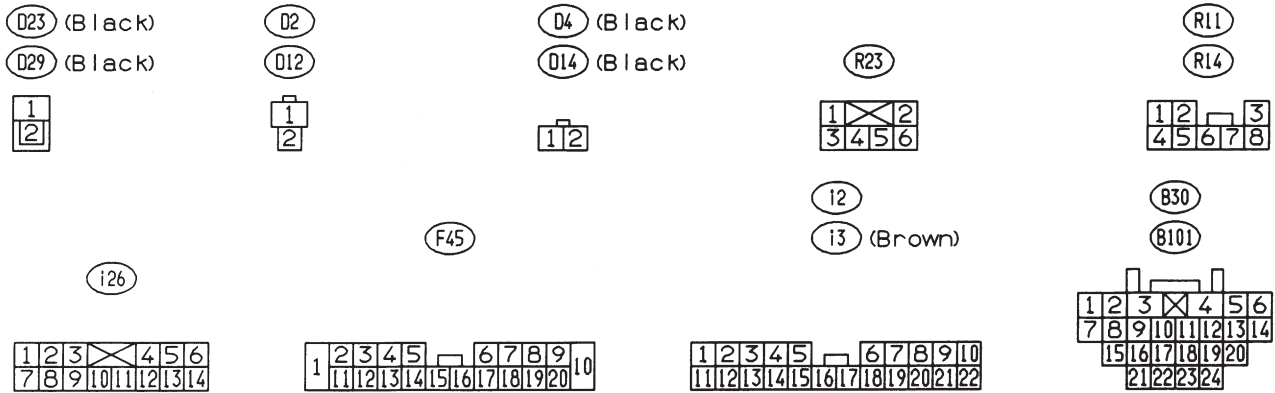
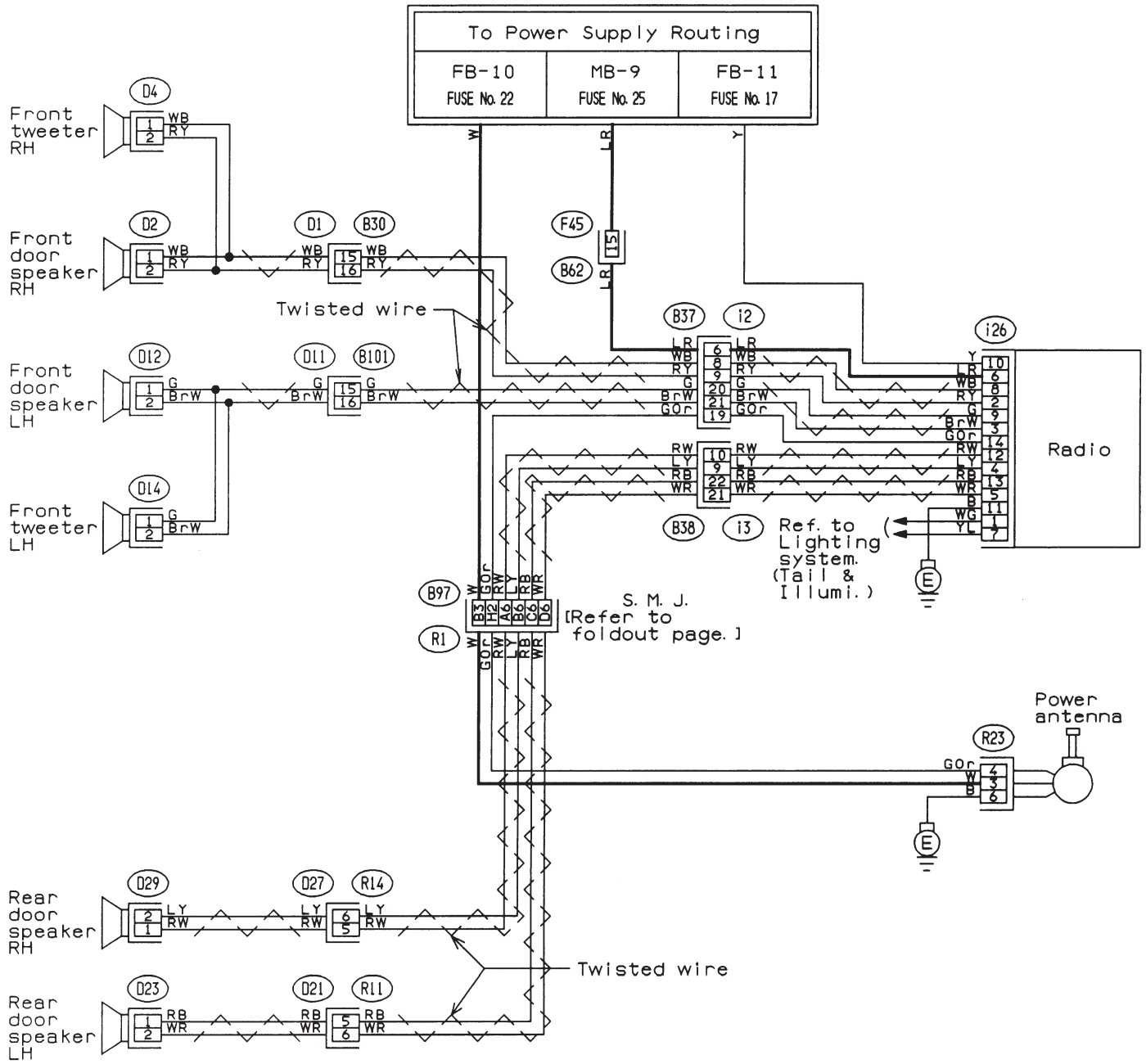

I: CHARGING SYSTEM

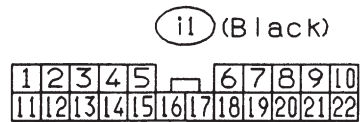
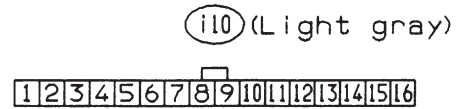
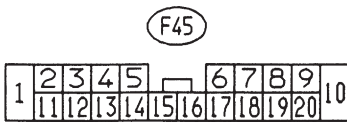
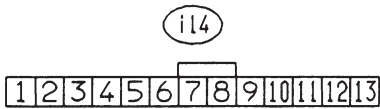
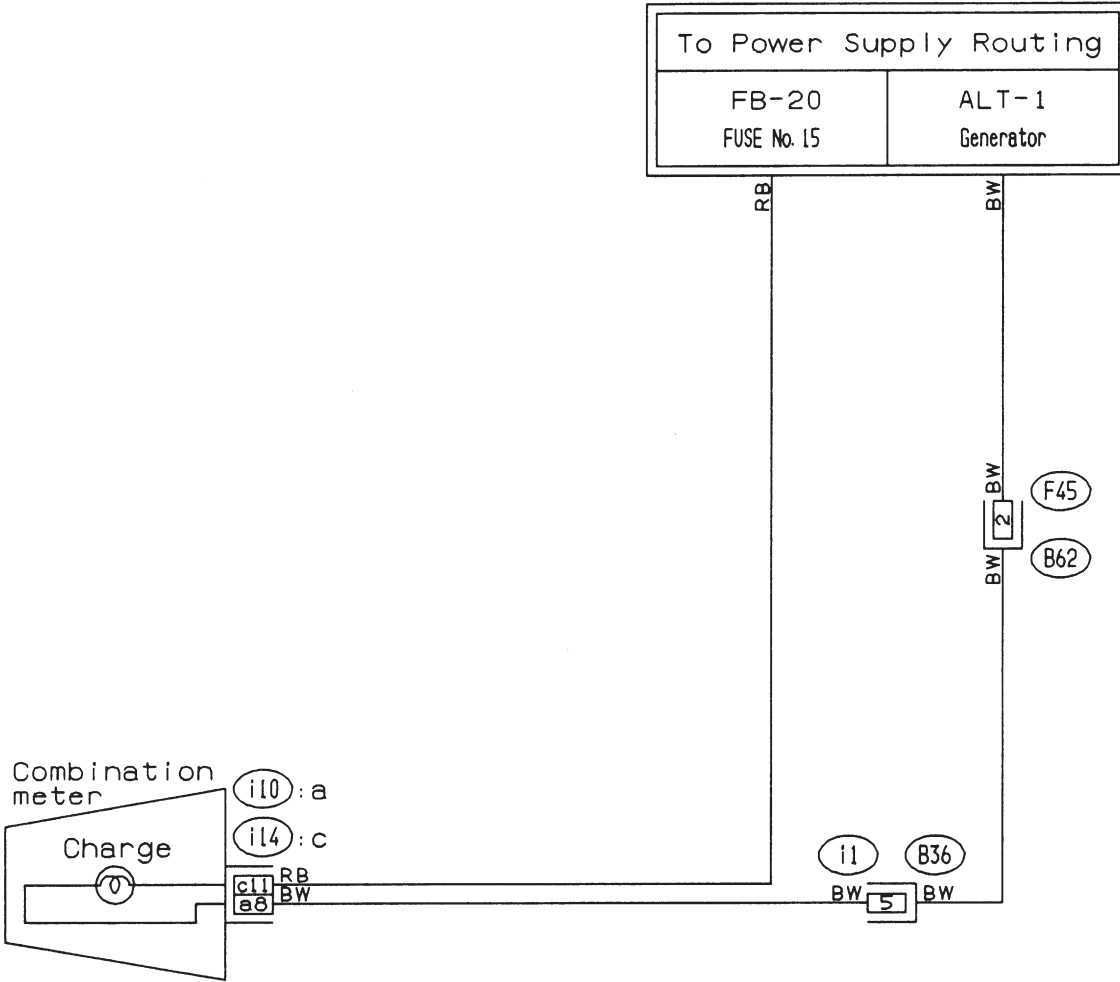

BU02-01

MEMO:

J: COMBINATION METER

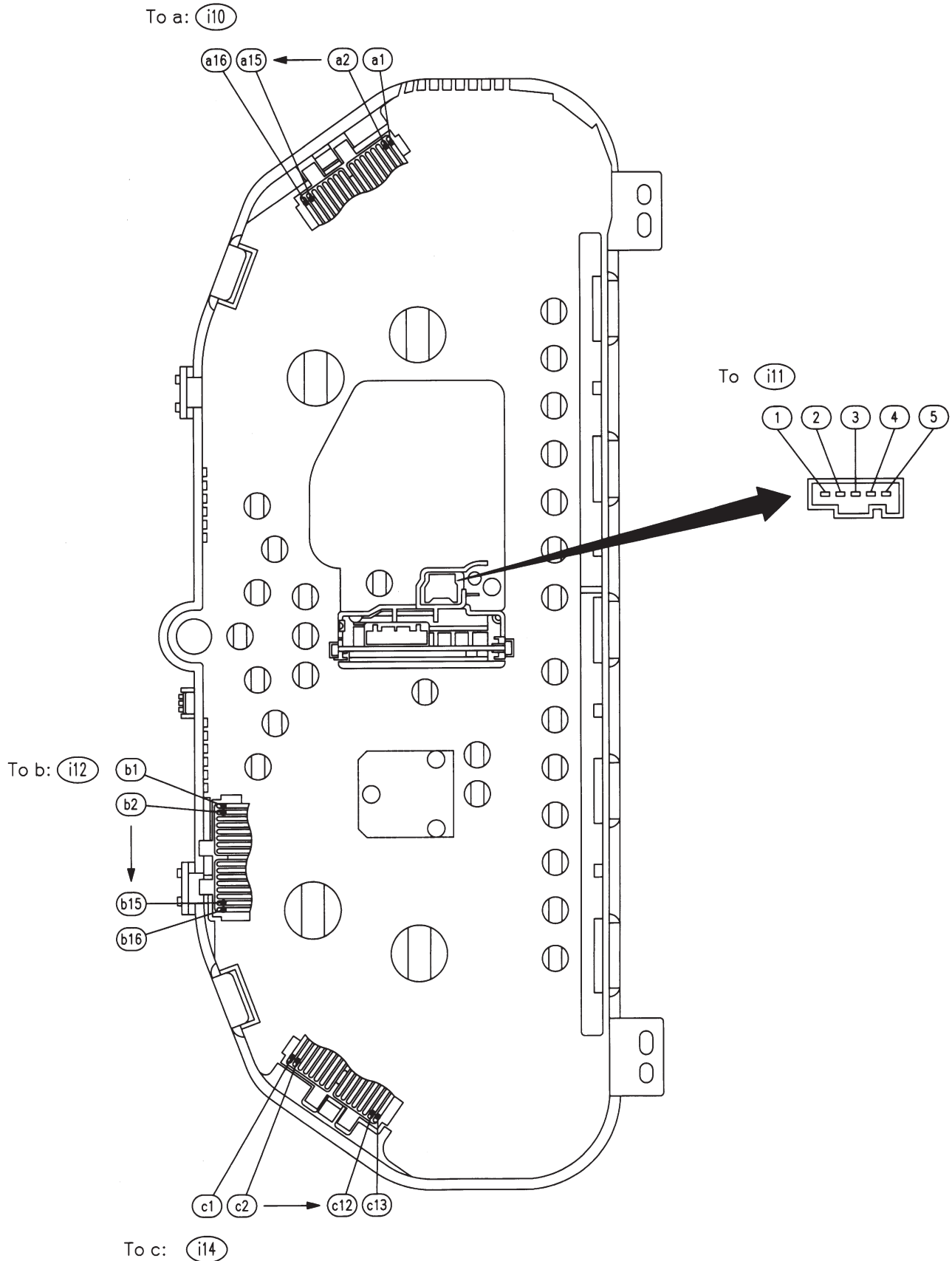

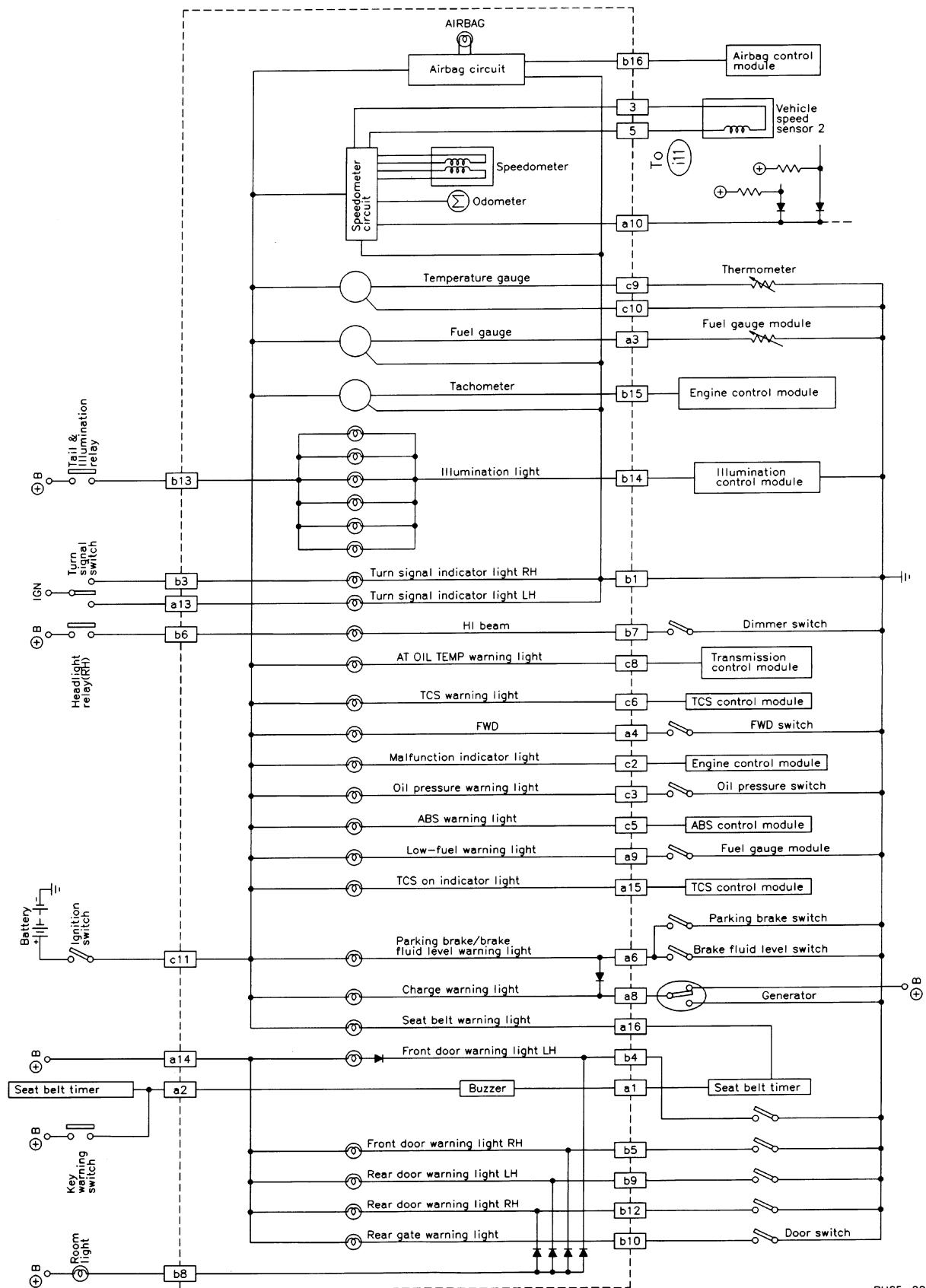

BU65-02B

K: CRUISE CONTROL SYSTEM

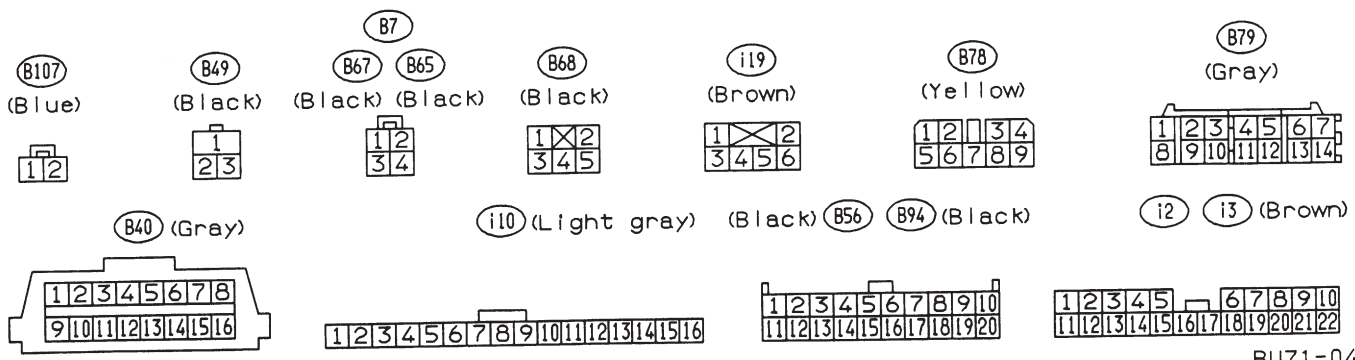
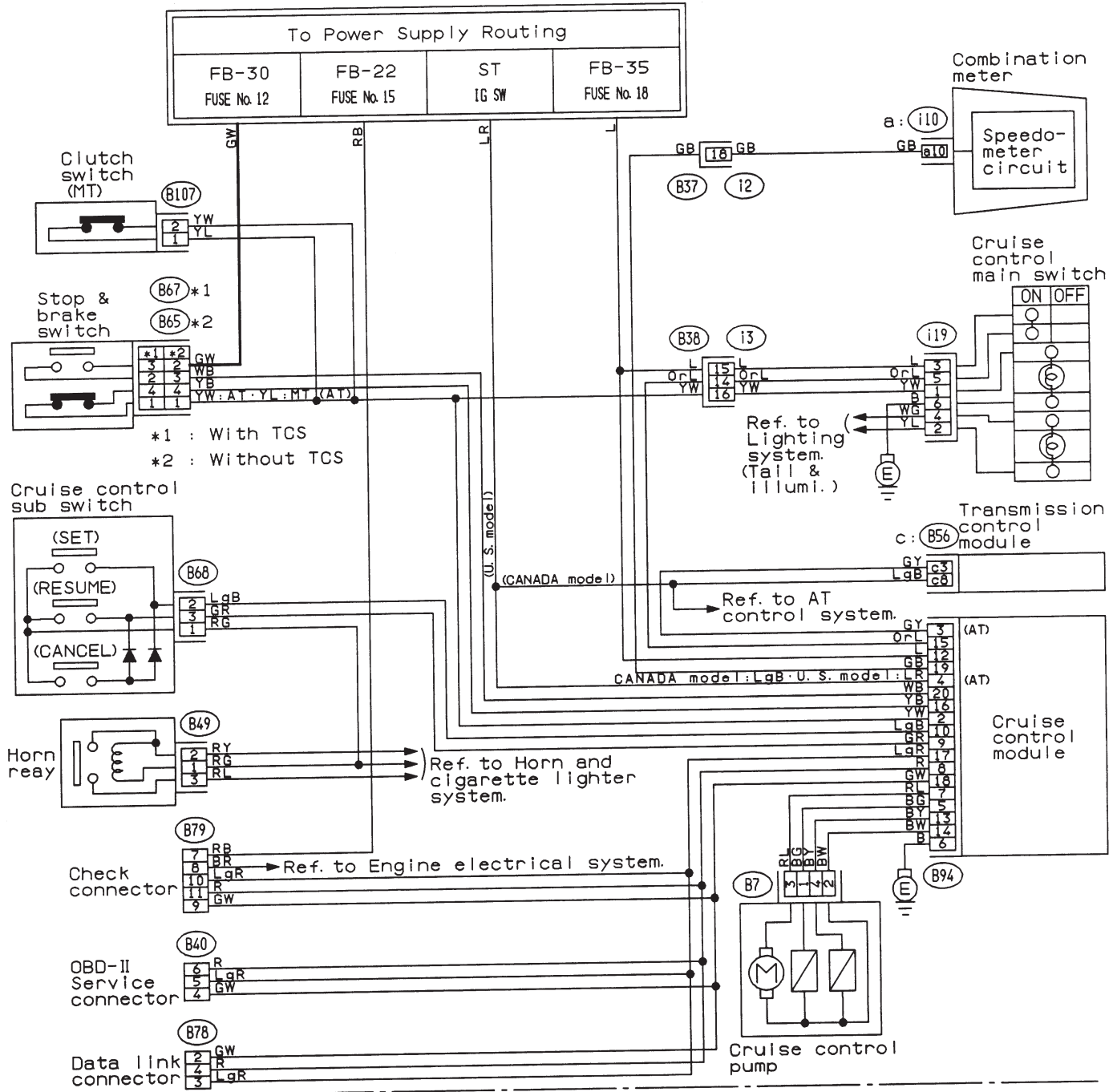

MEMO:

L: DOOR LOCK SYSTEM

1. LHD MODEL

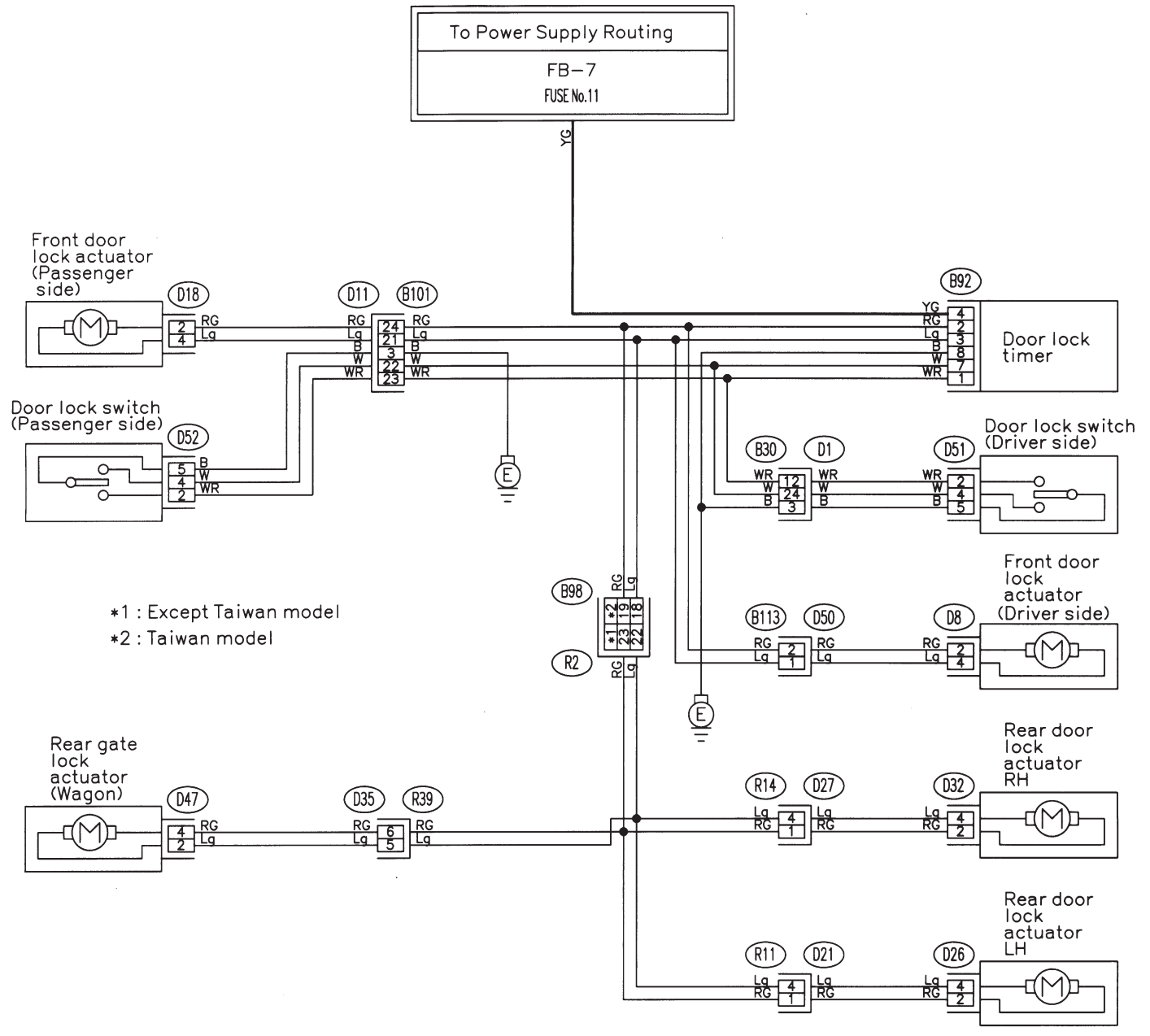

*1 : Except Taiwan model
*2 : Taiwan model

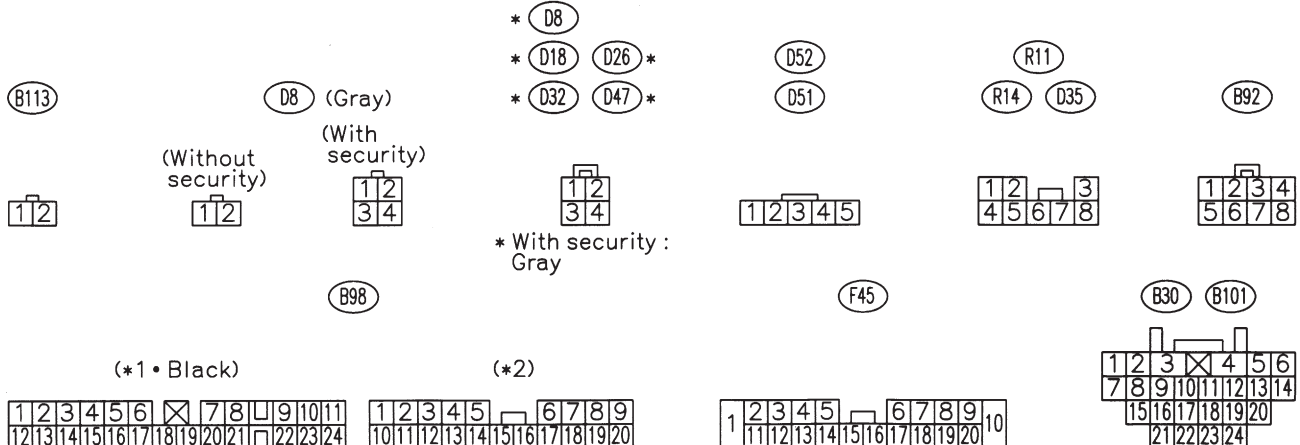

2. RHD MODEL

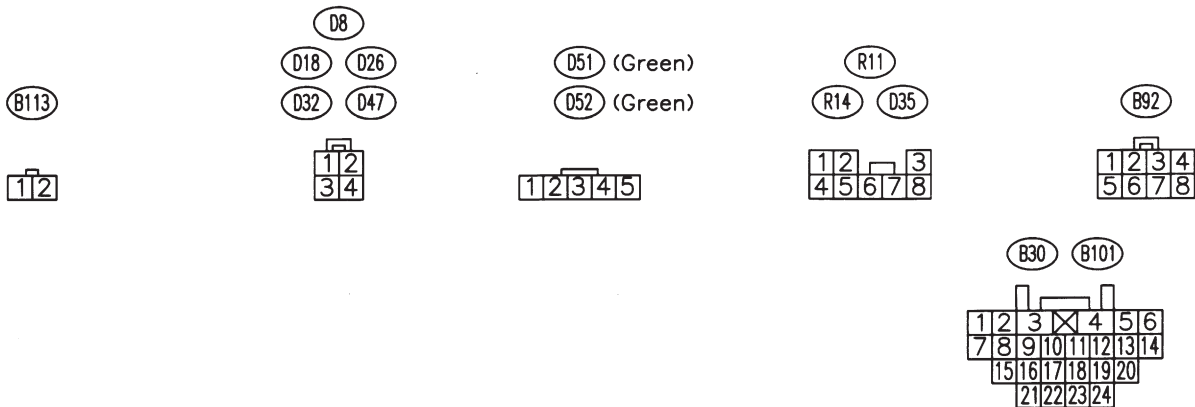
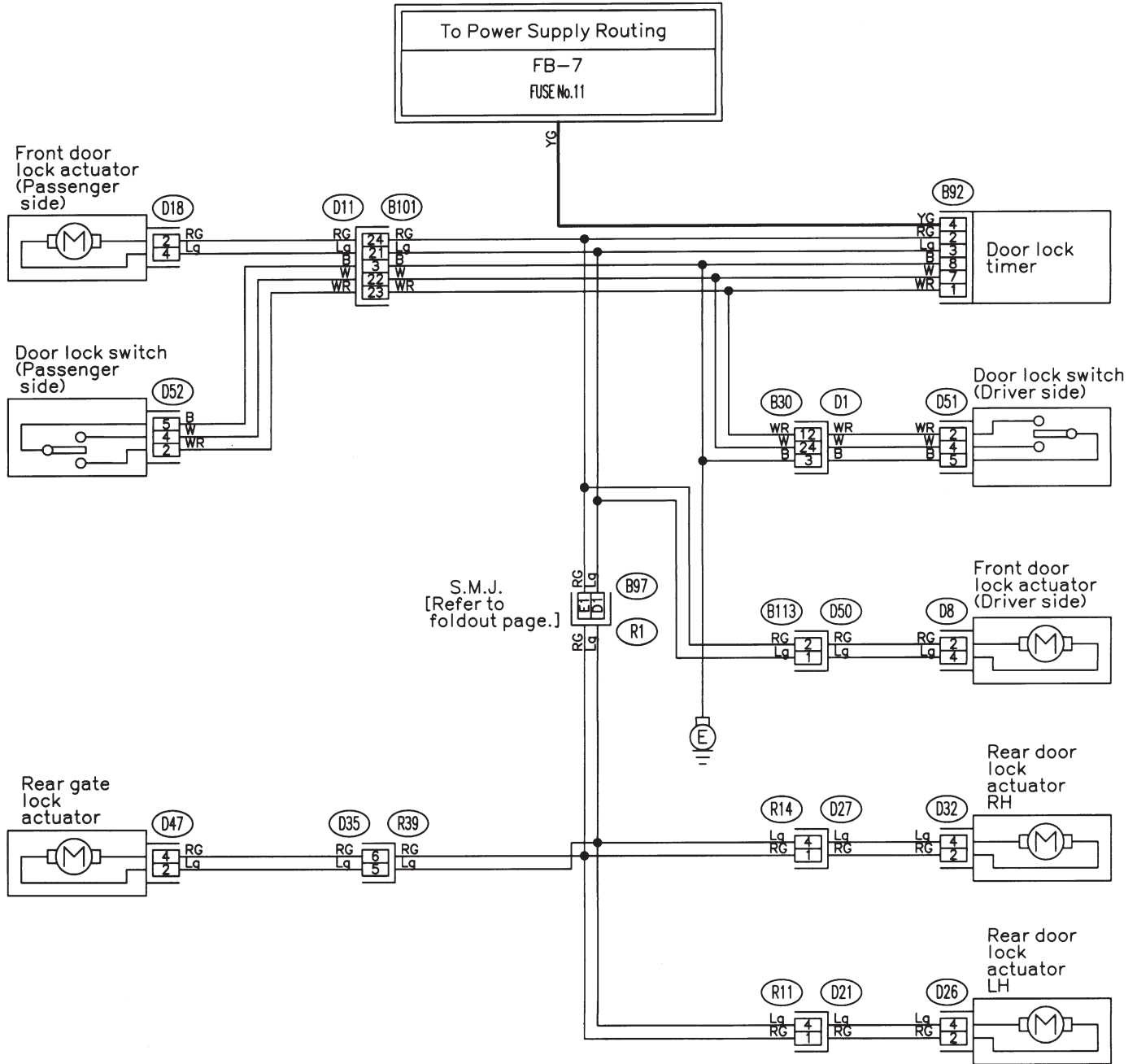

BUR73-02

M: ENGINE ELECTRICAL SYSTEM

1. TAIWAN MODEL

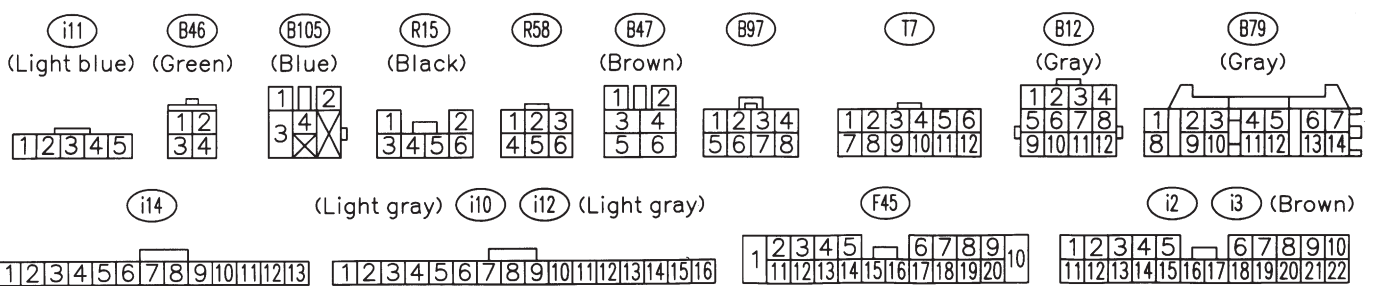
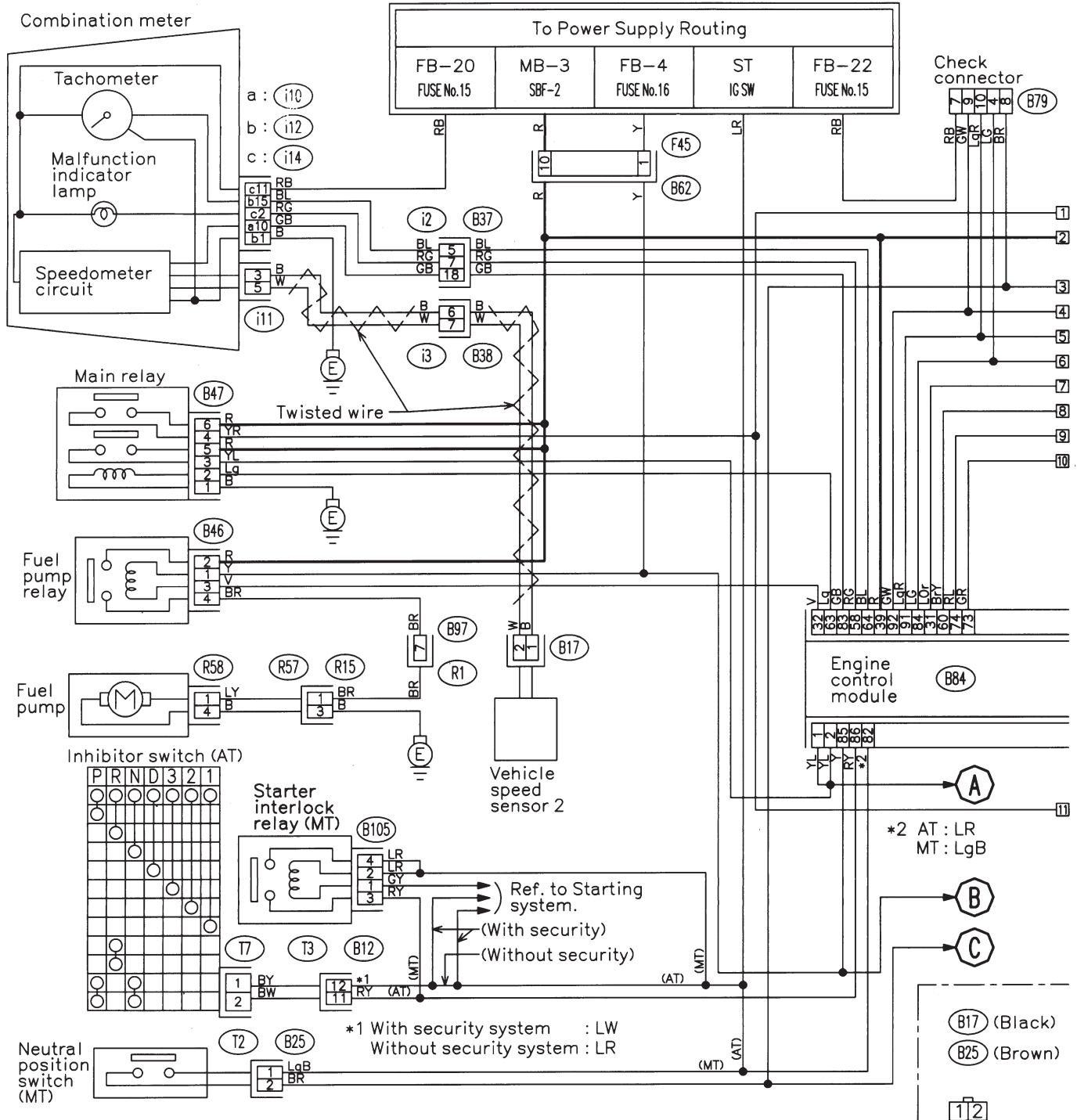

WIRING DIAGRAM

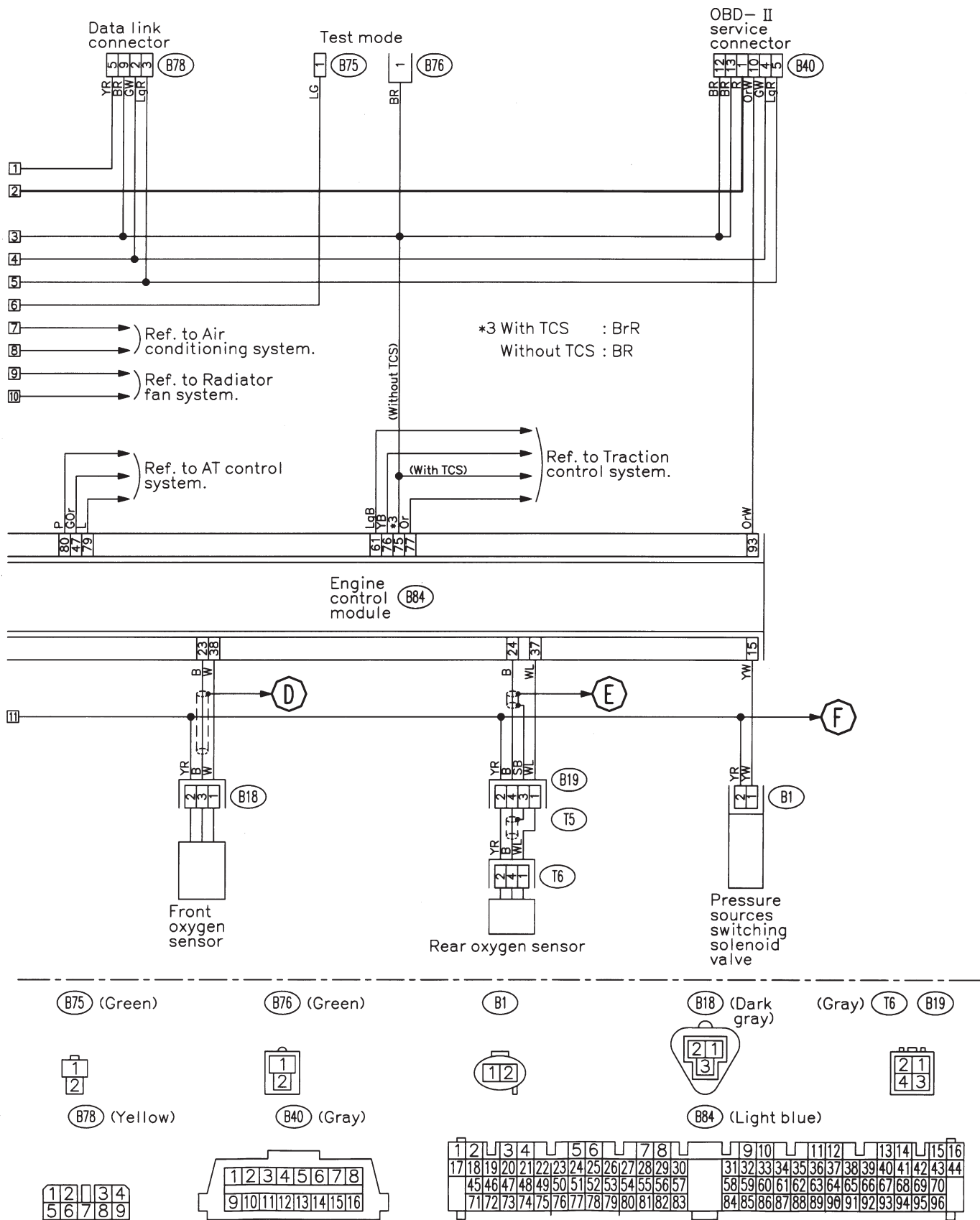

BU10-07B

WIRING DIAGRAM

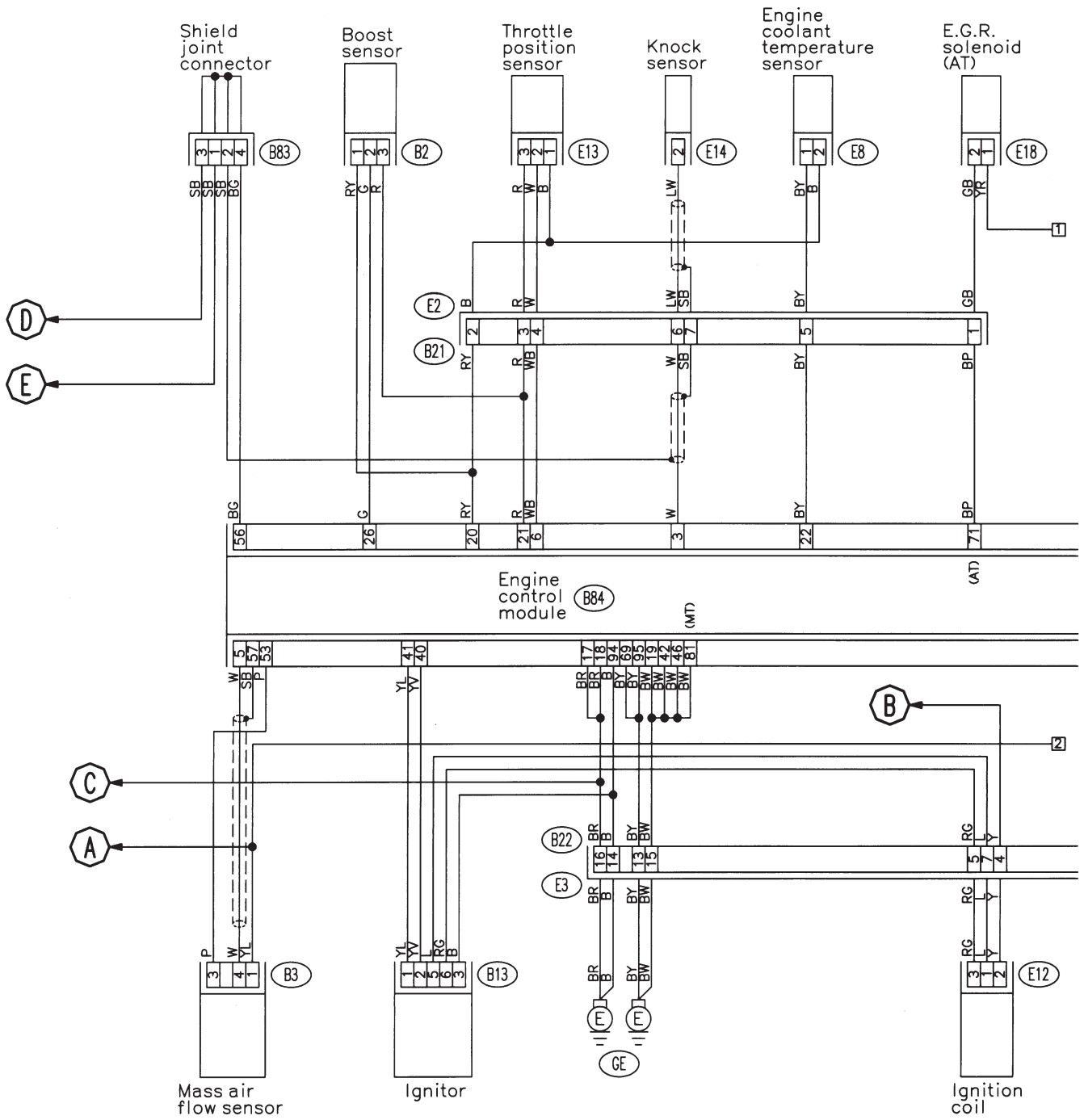

- (Brown) E18 (Gray) E14 (Gray)
 - (Black) B2 E13 (Brown) E12 (Gray) B83
 - B3 (Gray) B13 (Gray) B21 (Light gray) B22 (Light gray)
- Terminal block diagrams:
- Block 1: 1 2
 - Block 2: 1 2 3
 - Block 3: 1 2 3
 - Block 4: 1 2 3 4
 - Block 5: 1 2 3 4 5
 - Block 6: 1 2 3 4 5 6
 - Block 7: 1 2 3 4, 5 6 7 8, 9 10 11 12
 - Block 8: 1 2 3 4, 5 6 7 8, 9 10 11 12, 13 14 15 16

BU10-07C

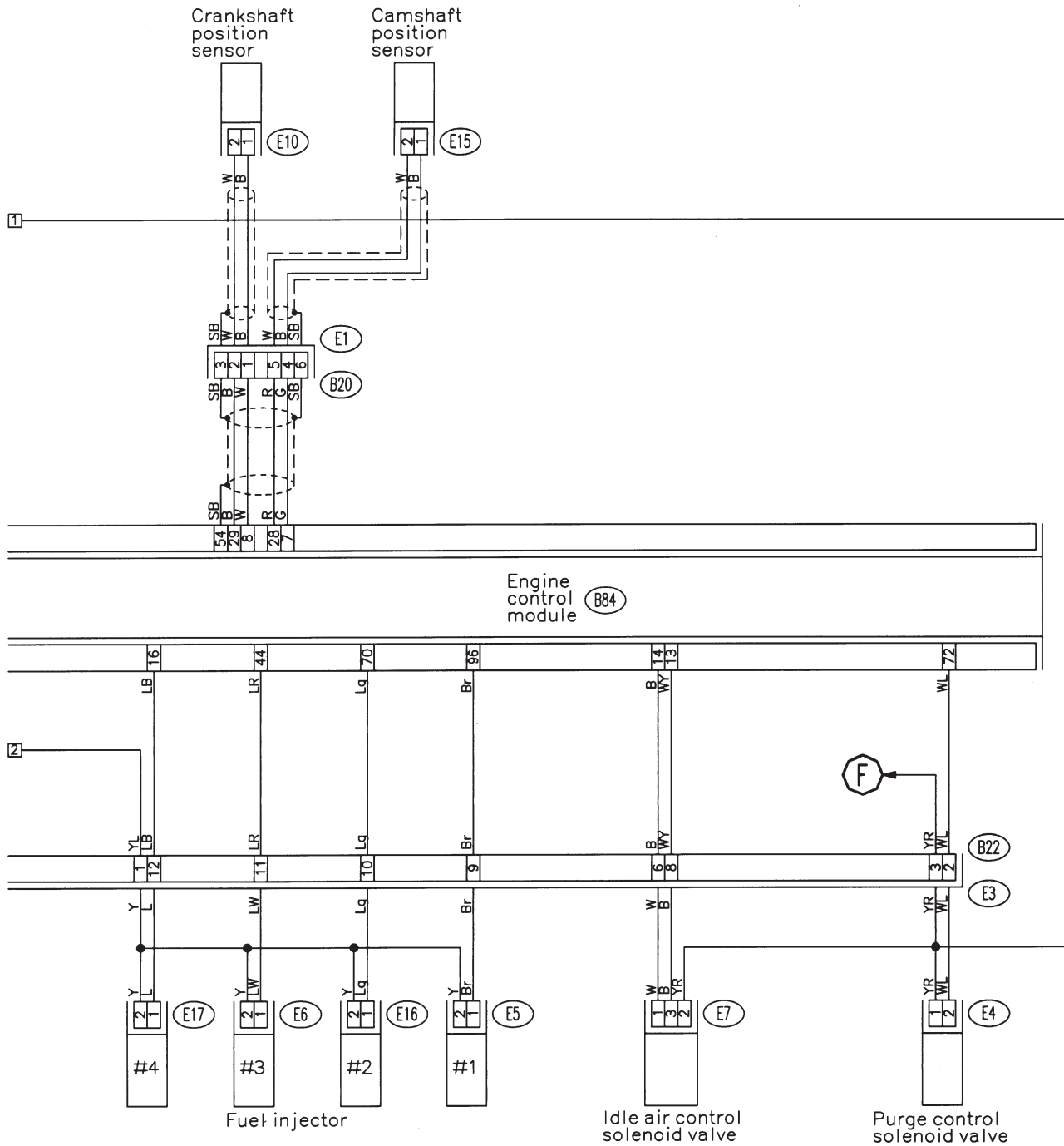

- (E15) (Dark gray) (Light gray) (E5) (E16) (Light gray)
- (E10) (Gray) (Dark gray) (E6) (E17) (Dark gray)



- (B84) (Light blue)

- (E4) (Blue)

- (E7) (Gray)

- (B20) (Light gray)



1	2	3	4	5	6	7	8	9	10	11	12	13	14	15	16																																				
17	18	19	20	21	22	23	24	25	26	27	28	29	30	31	32	33	34	35	36	37	38	39	40	41	42	43	44																								
45	46	47	48	49	50	51	52	53	54	55	56	57	58	59	60	61	62	63	64	65	66	67	68	69	70	71	72	73	74	75	76	77	78	79	80	81	82	83	84	85	86	87	88	89	90	91	92	93	94	95	96

2. LHD EXCEPT TAIWAN MODEL

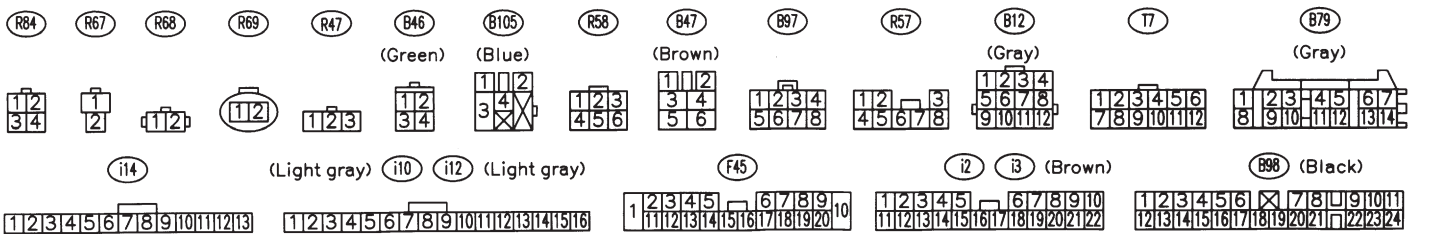
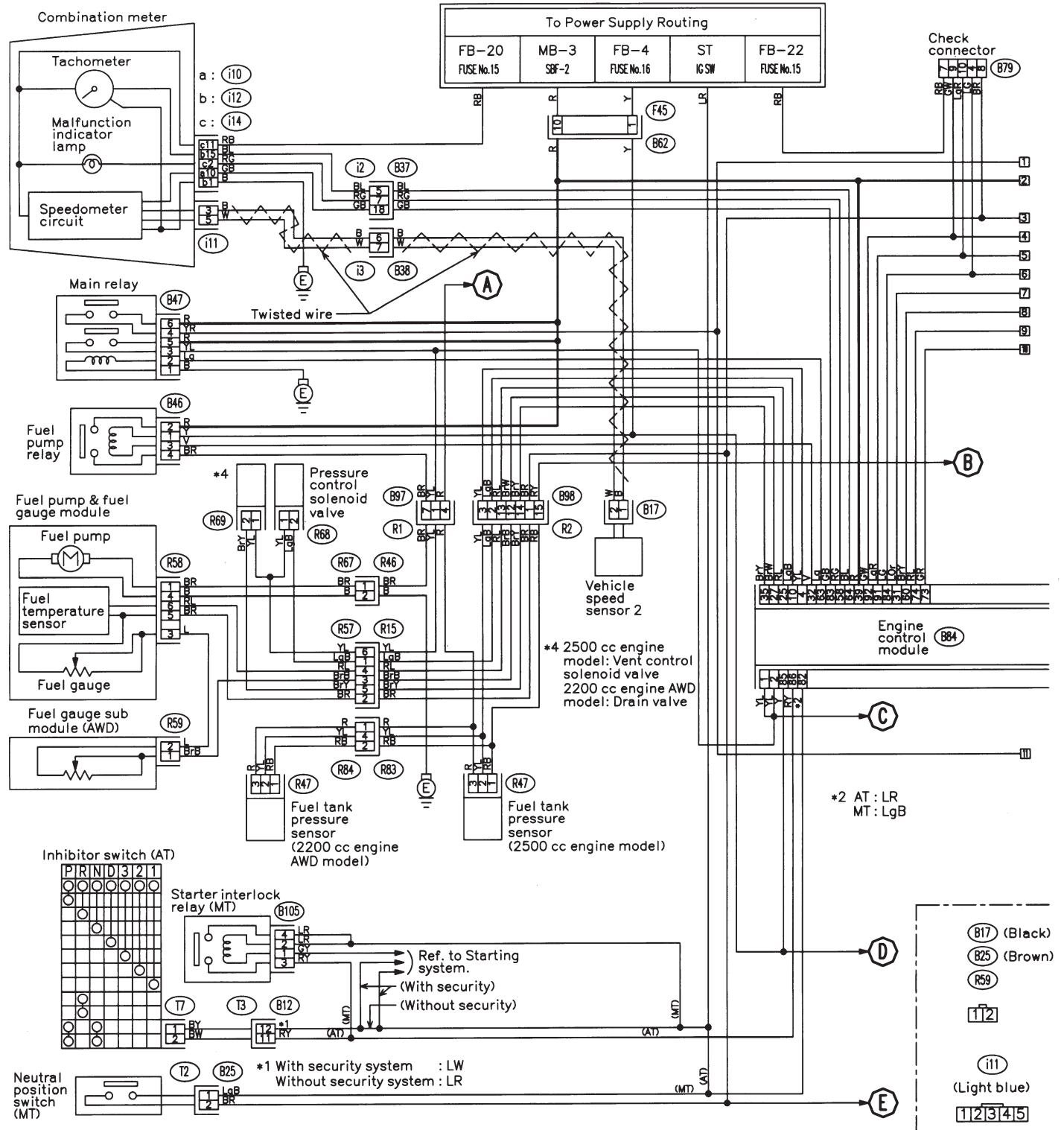

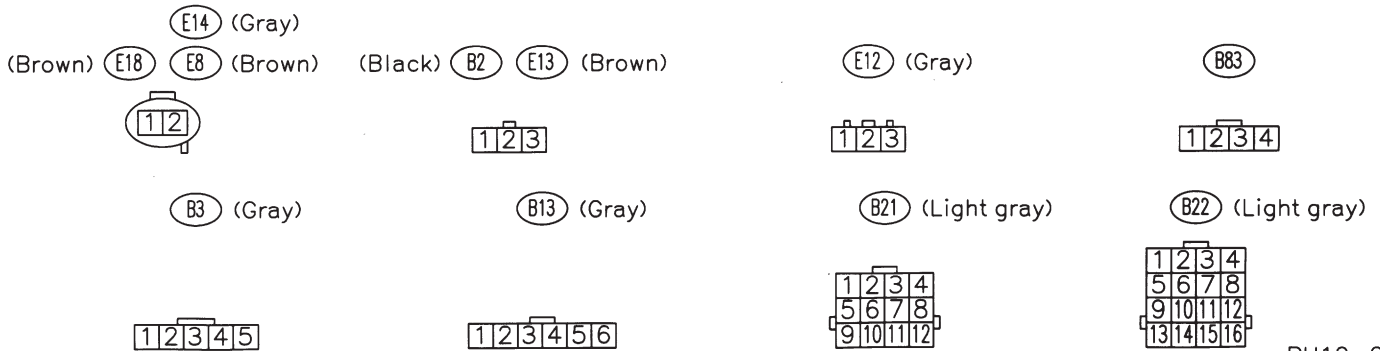
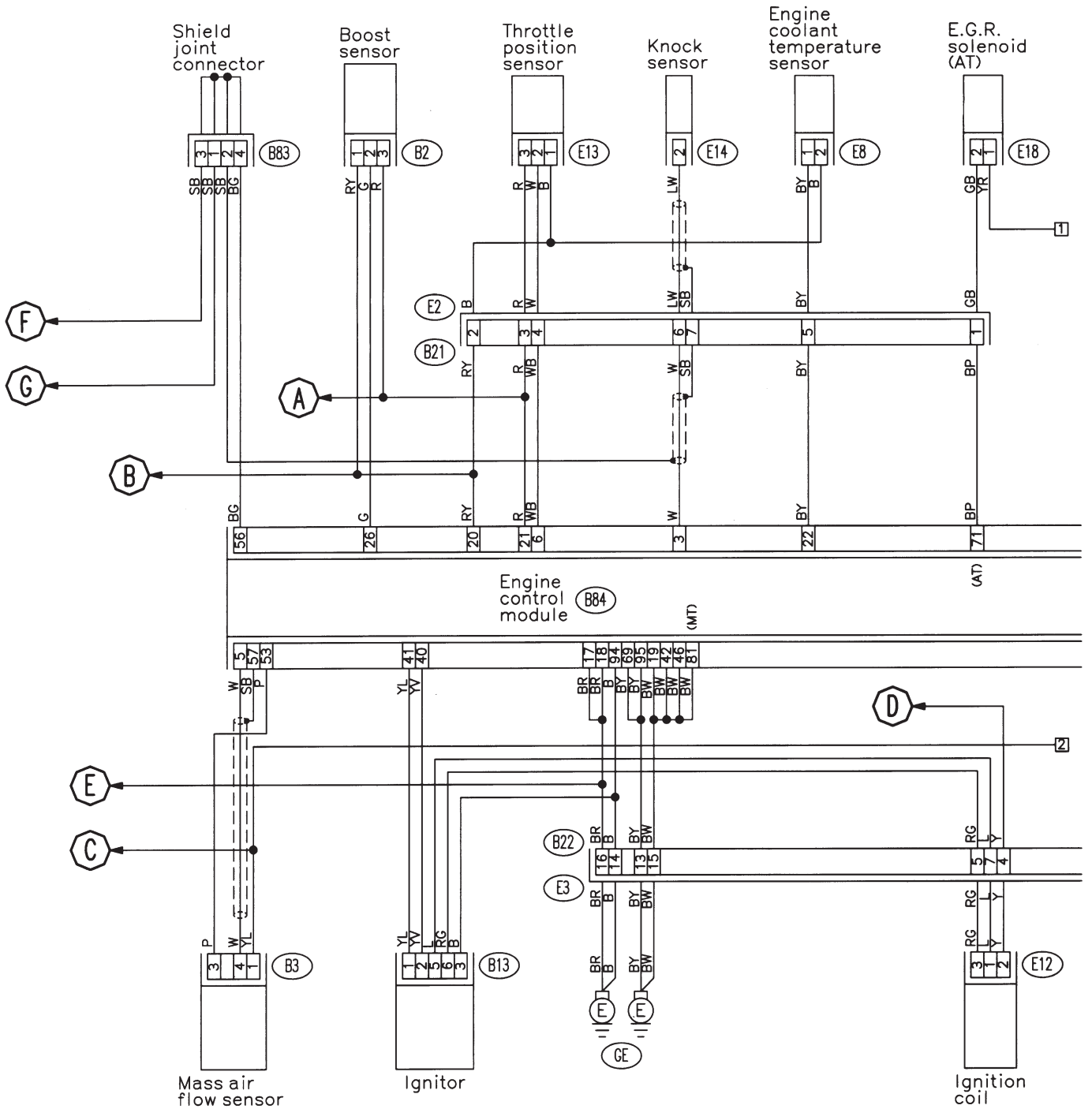

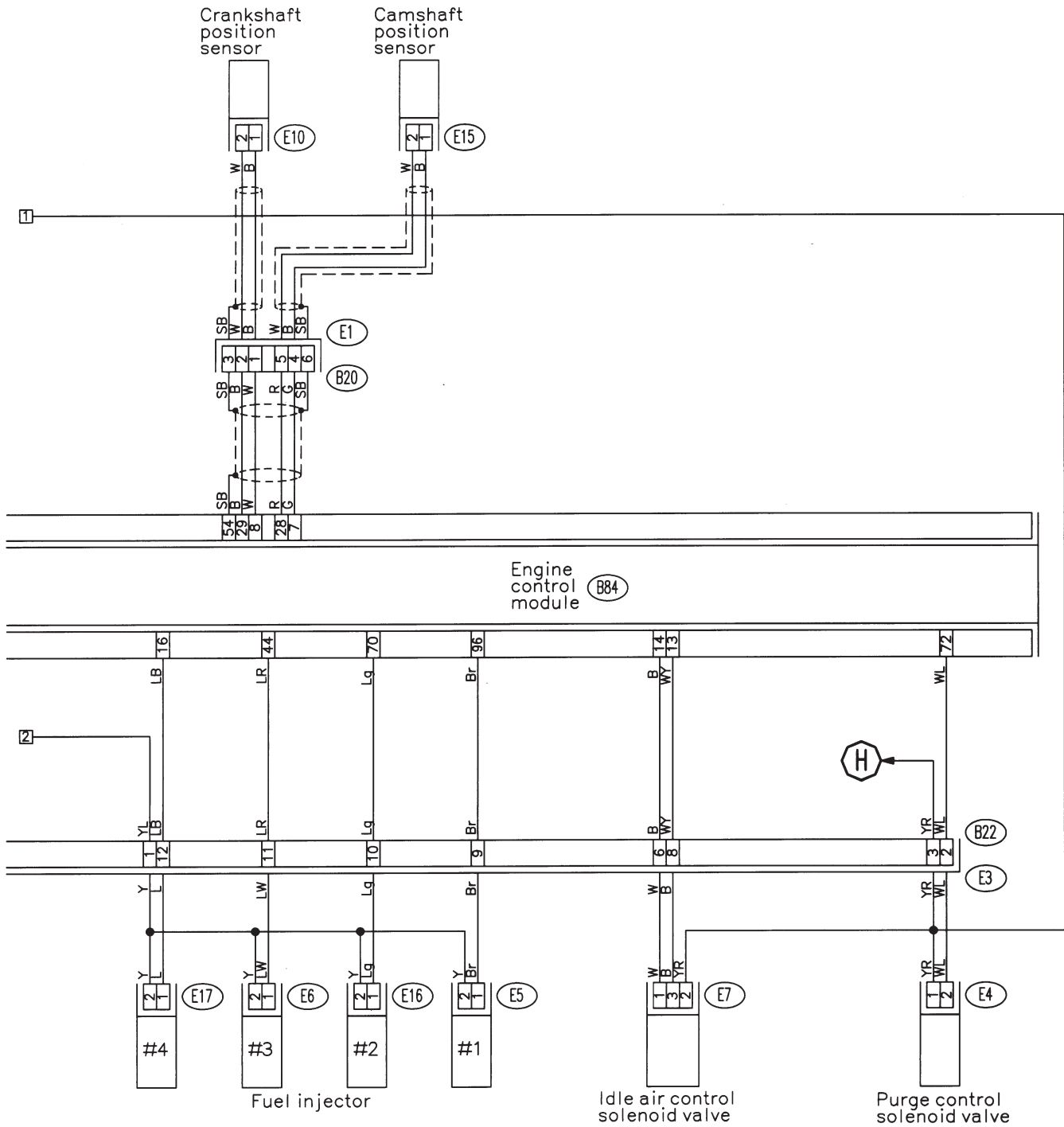

- (E15) (Dark gray) (Light gray) (E5) (E16) (Light gray)
- (E10) (Gray) (Dark gray) (E6) (E17) (Dark gray)



(B84) (Light blue)

(E4) (Blue)

(E7) (Gray)

(B20) (Light gray)



1	2	3	4	5	6	7	8	9	10	11	12	13	14	15	16																																				
17	18	19	20	21	22	23	24	25	26	27	28	29	30	31	32	33	34	35	36	37	38	39	40	41	42	43	44																								
45	46	47	48	49	50	51	52	53	54	55	56	57	58	59	60	61	62	63	64	65	66	67	68	69	70	71	72	73	74	75	76	77	78	79	80	81	82	83	84	85	86	87	88	89	90	91	92	93	94	95	96

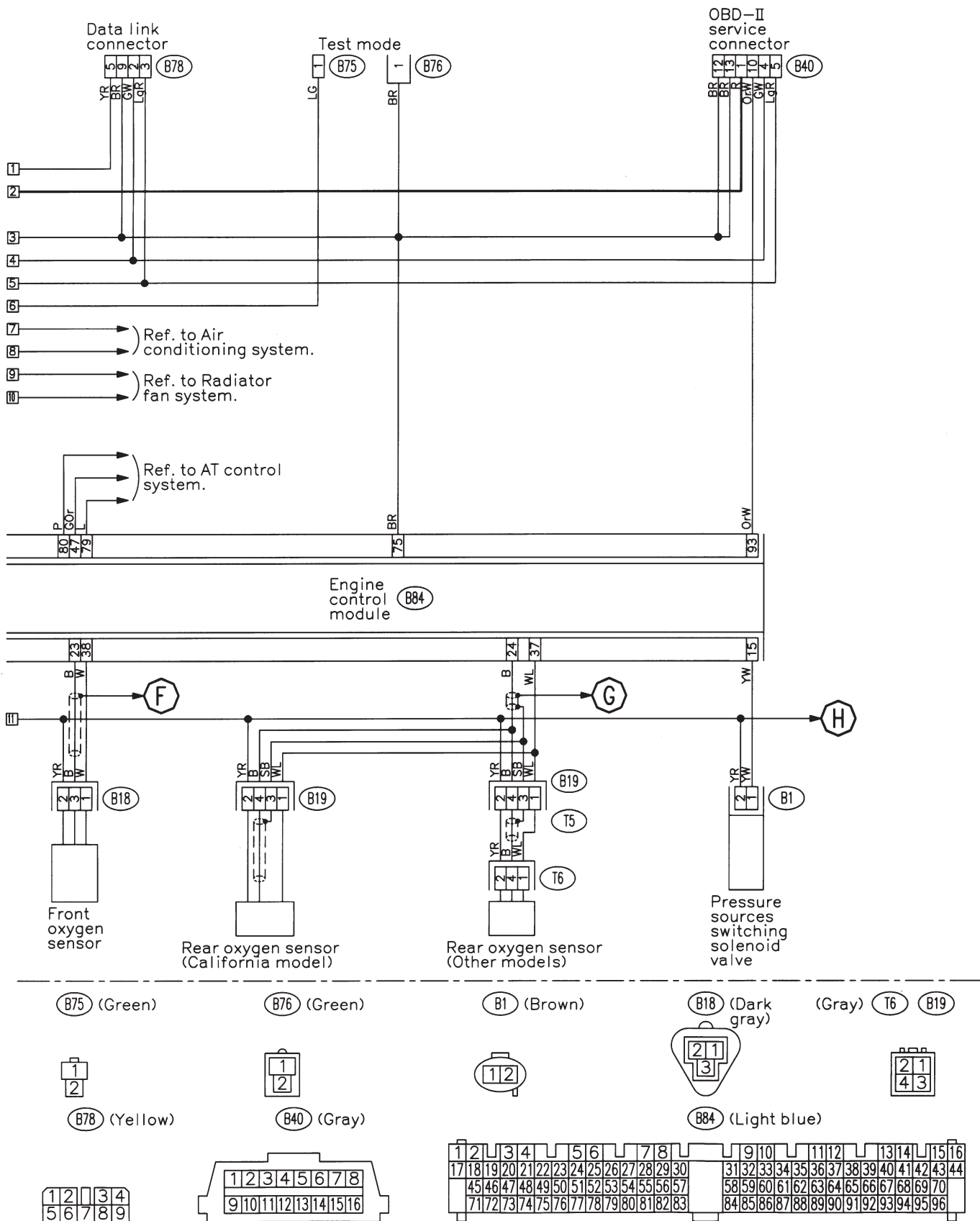

BP10-05B

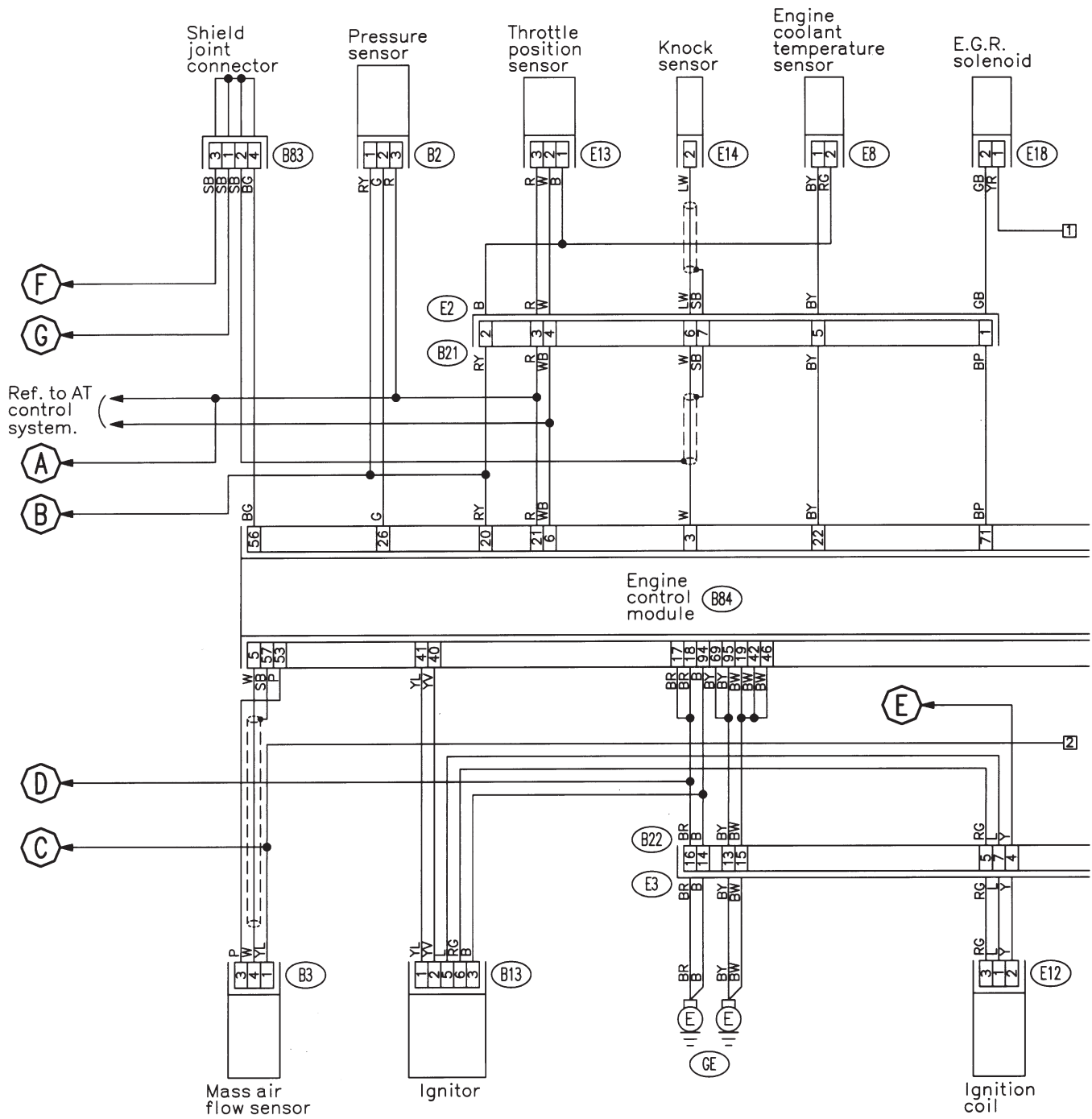

- (Brown) E18 E8 (Brown) (Black) B2 E13 (Brown) E12 (Gray) B83
- E14 (Gray)
- 1 2
- B3 (Gray) B13 (Gray) B21 (Light gray) B22 (Light gray)
- 1 2 3 1 2 3 1 2 3 4
- 1 2 3 4 5 1 2 3 4 5 6 1 2 3 4
5 6 7 8 9 10 11 12 5 6 7 8
13 14 15 16

BP10-05C

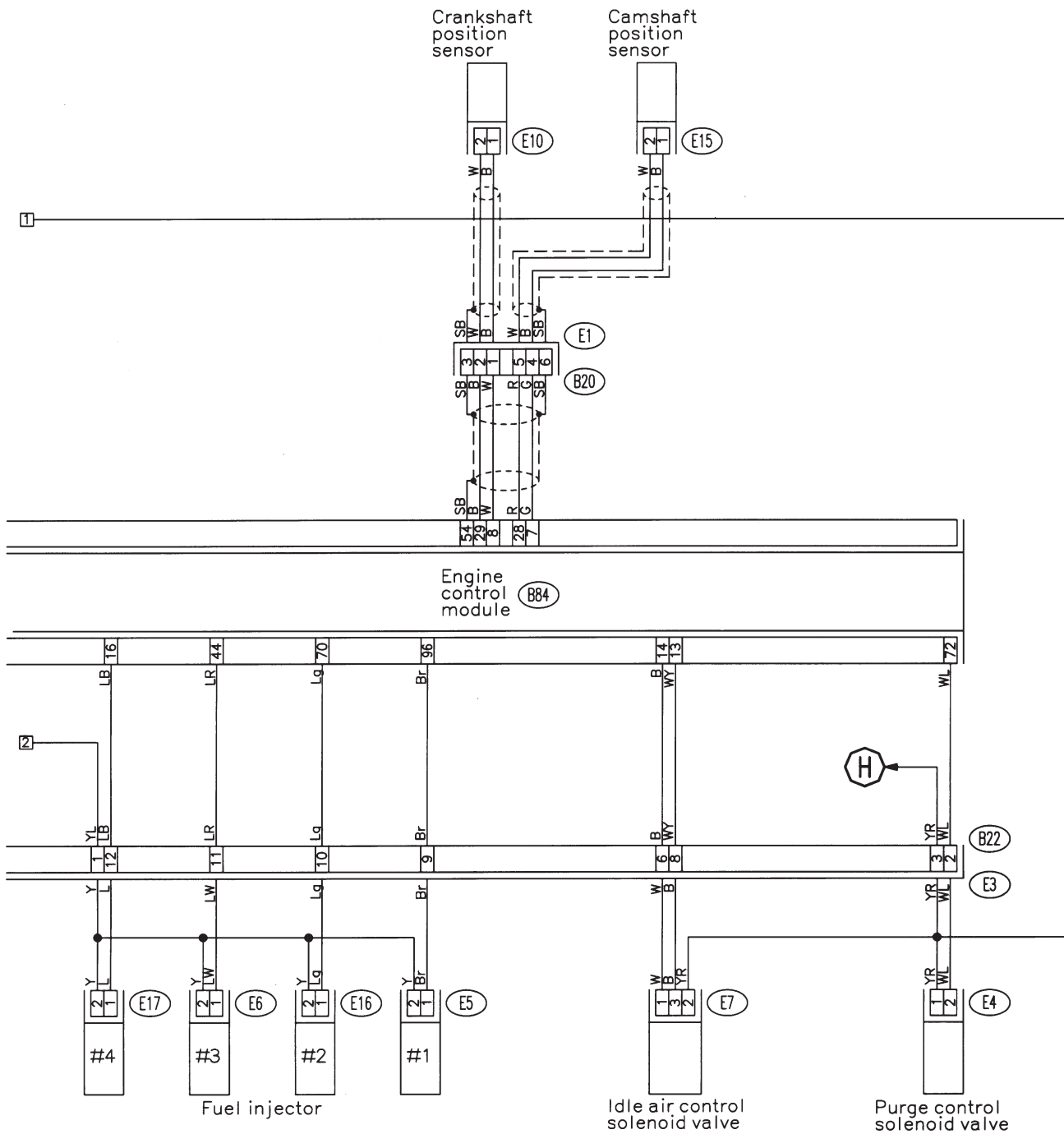

- (E15) (Dark gray) (Light gray) (E5) (E16) (Light gray)
- (E10) (Gray) (Dark gray) (E6) (E17) (Dark gray)



(B84) (Light blue)

(E4) (Blue)

(E7) (Gray)

(B20) (Light gray)



1	2	3	4	5	6	7	8	9	10	11	12	13	14	15	16																																				
17	18	19	20	21	22	23	24	25	26	27	28	29	30	31	32	33	34	35	36	37	38	39	40	41	42	43	44																								
45	46	47	48	49	50	51	52	53	54	55	56	57	58	59	60	61	62	63	64	65	66	67	68	69	70	71	72	73	74	75	76	77	78	79	80	81	82	83	84	85	86	87	88	89	90	91	92	93	94	95	96

N: FUEL GAUGE SYSTEM

1. TAIWAN MODEL

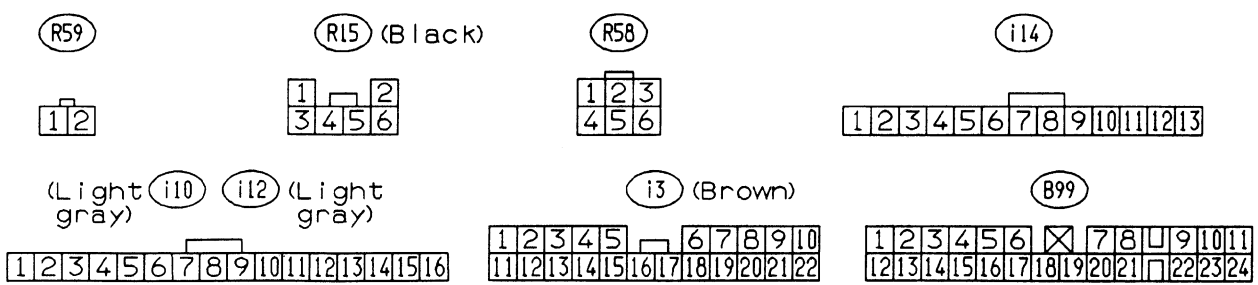
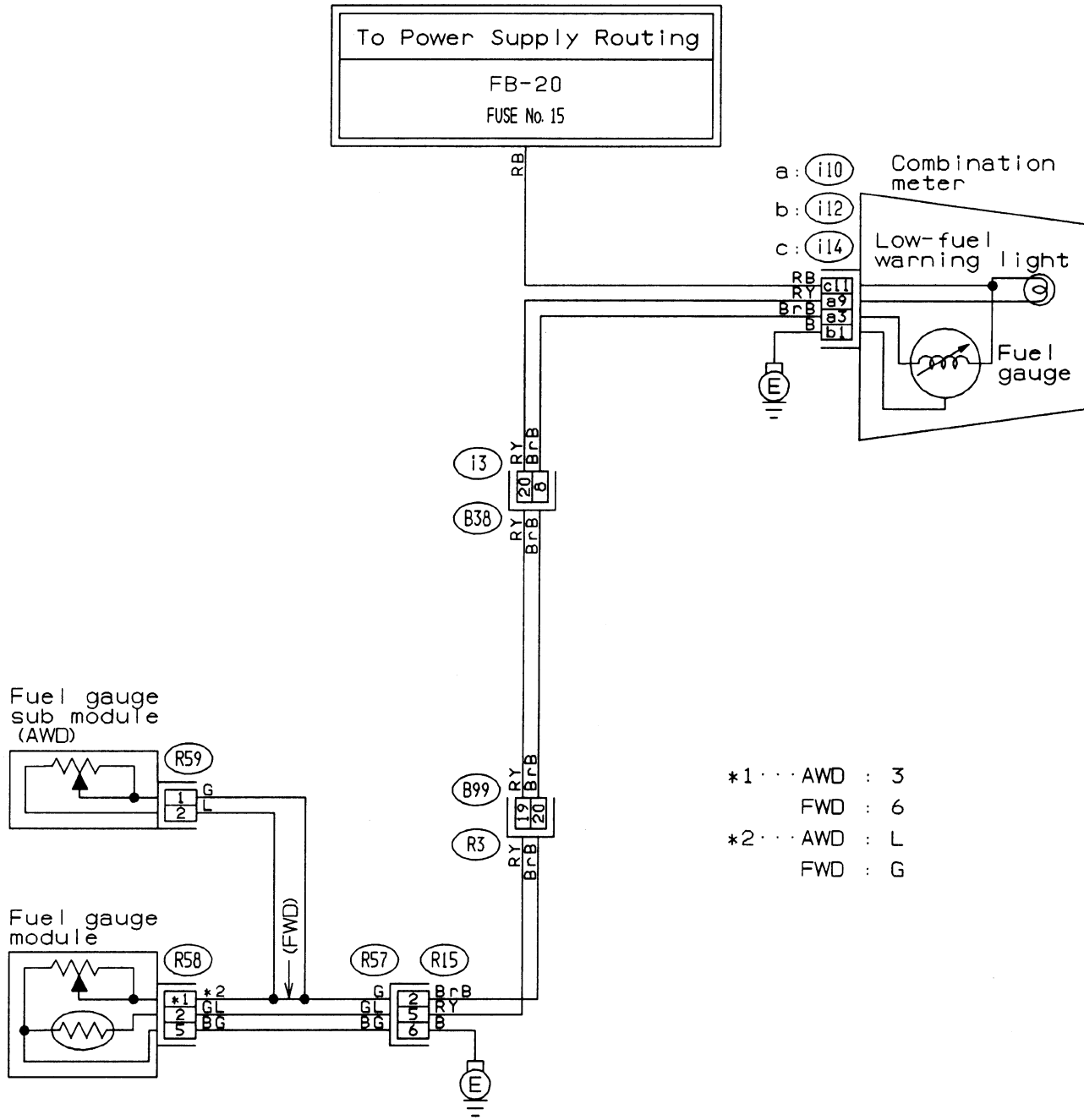

2. LHD EXCEPT TAIWAN MODEL

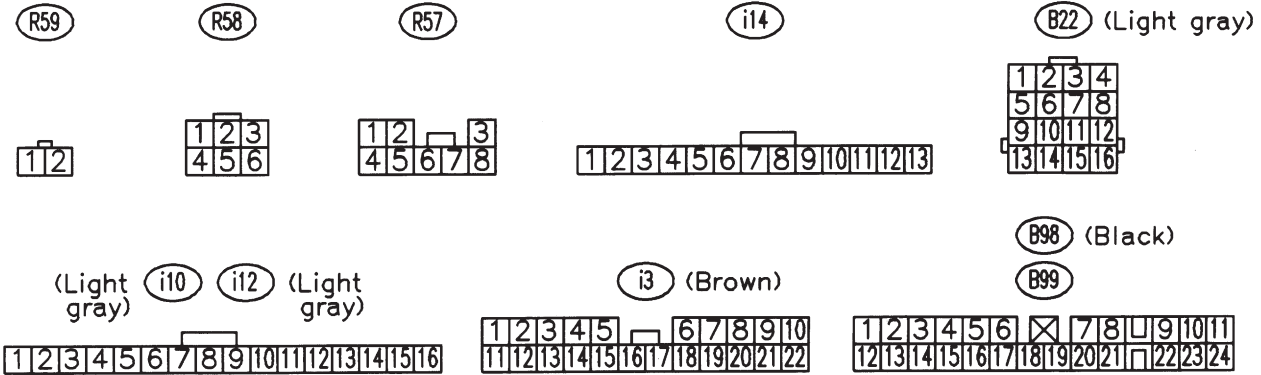
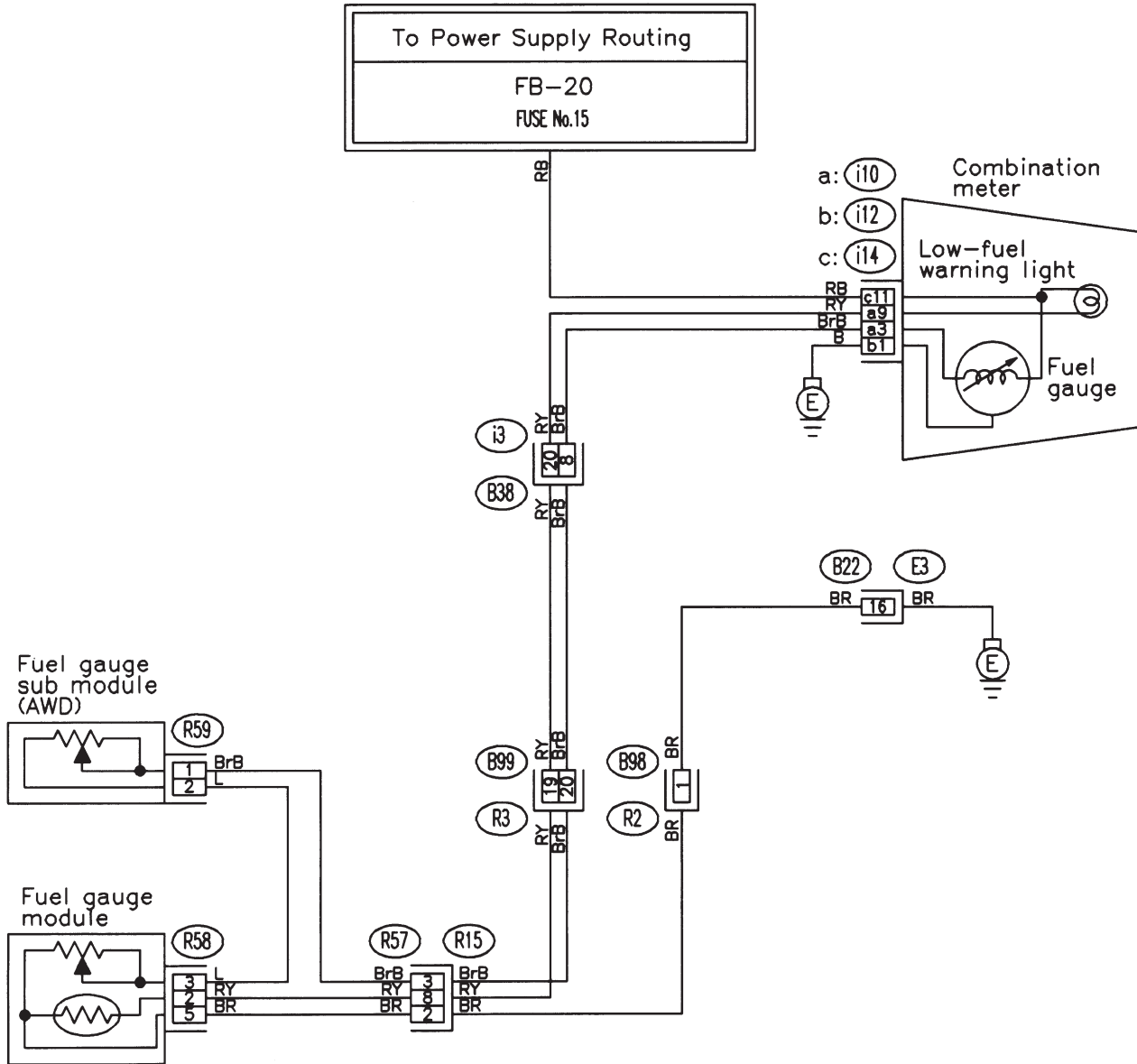

BU61-02

3. RHD MODEL

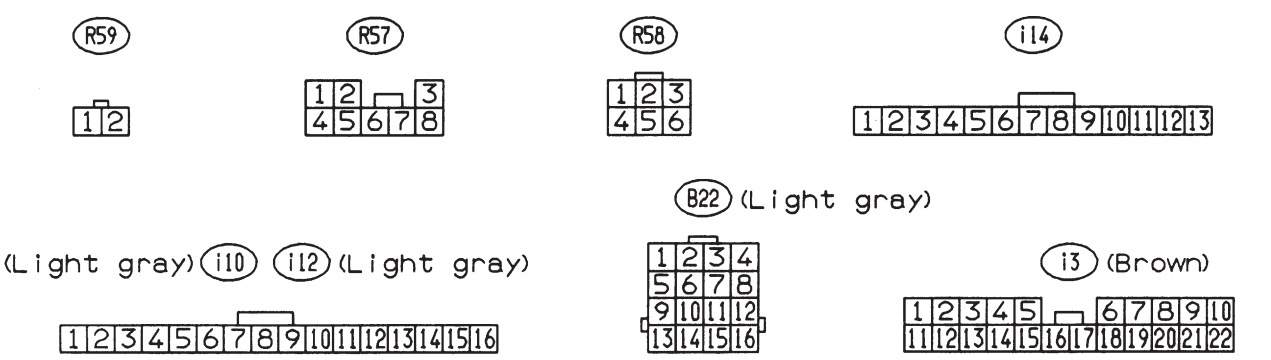
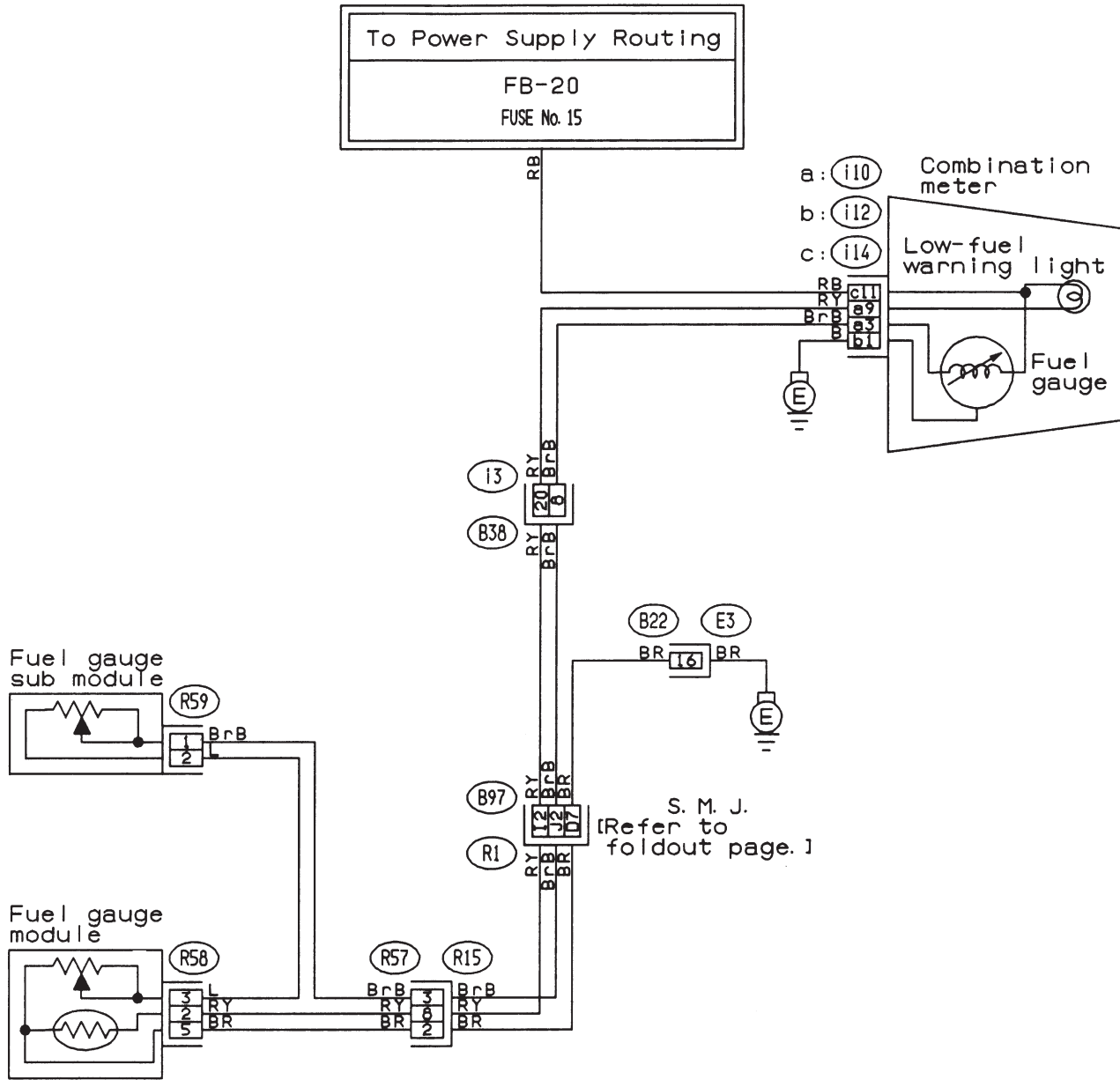

BUR61-02

MEMO:

O: HORN AND FRONT ACCESSORY POWER SUPPLY SYSTEM

1. LHD MODEL

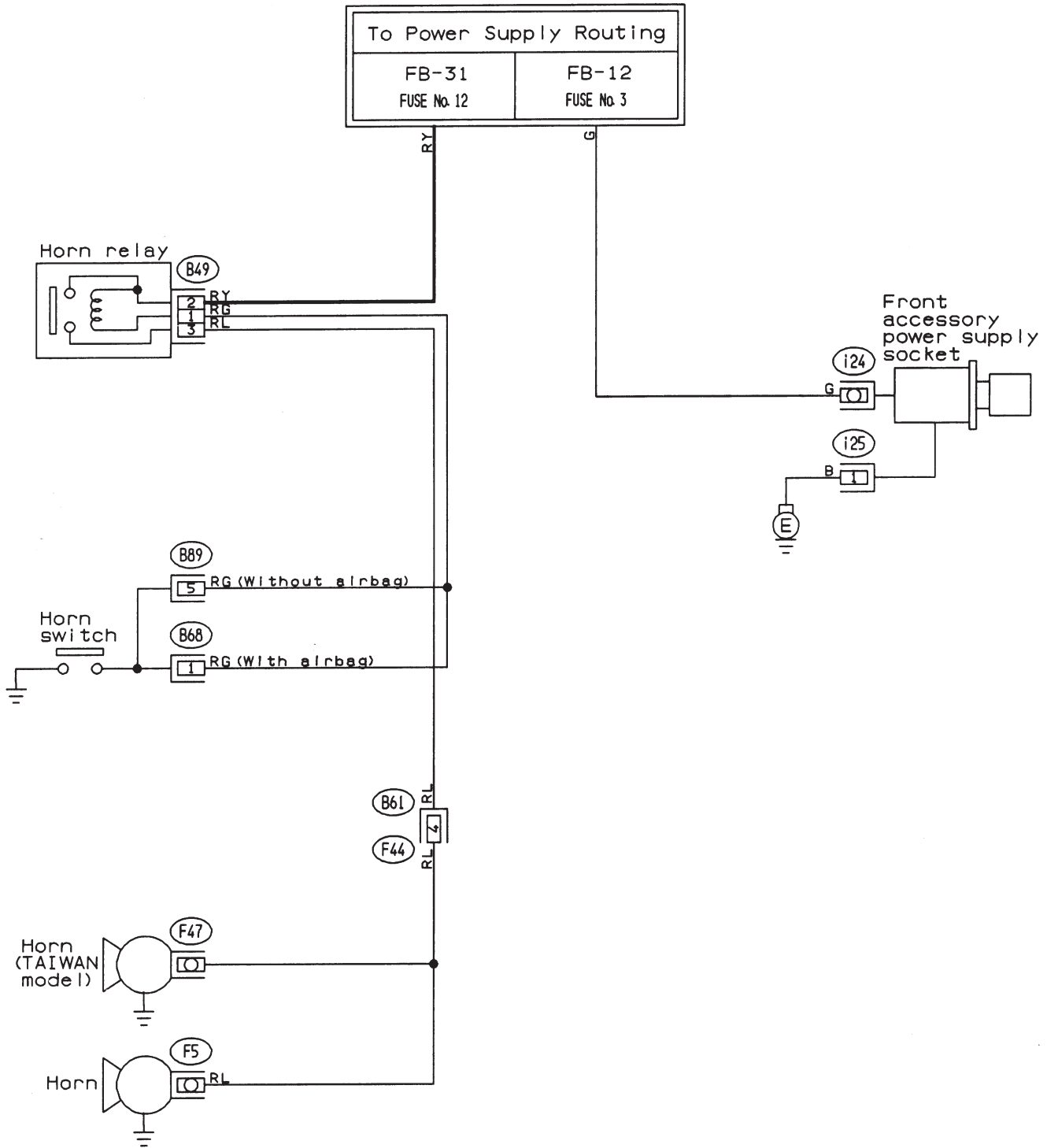

i25

B49 (Black)



B68 (Black)



F44



B89 (Black)

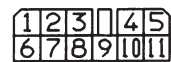

BU74-02

2. RHD MODEL

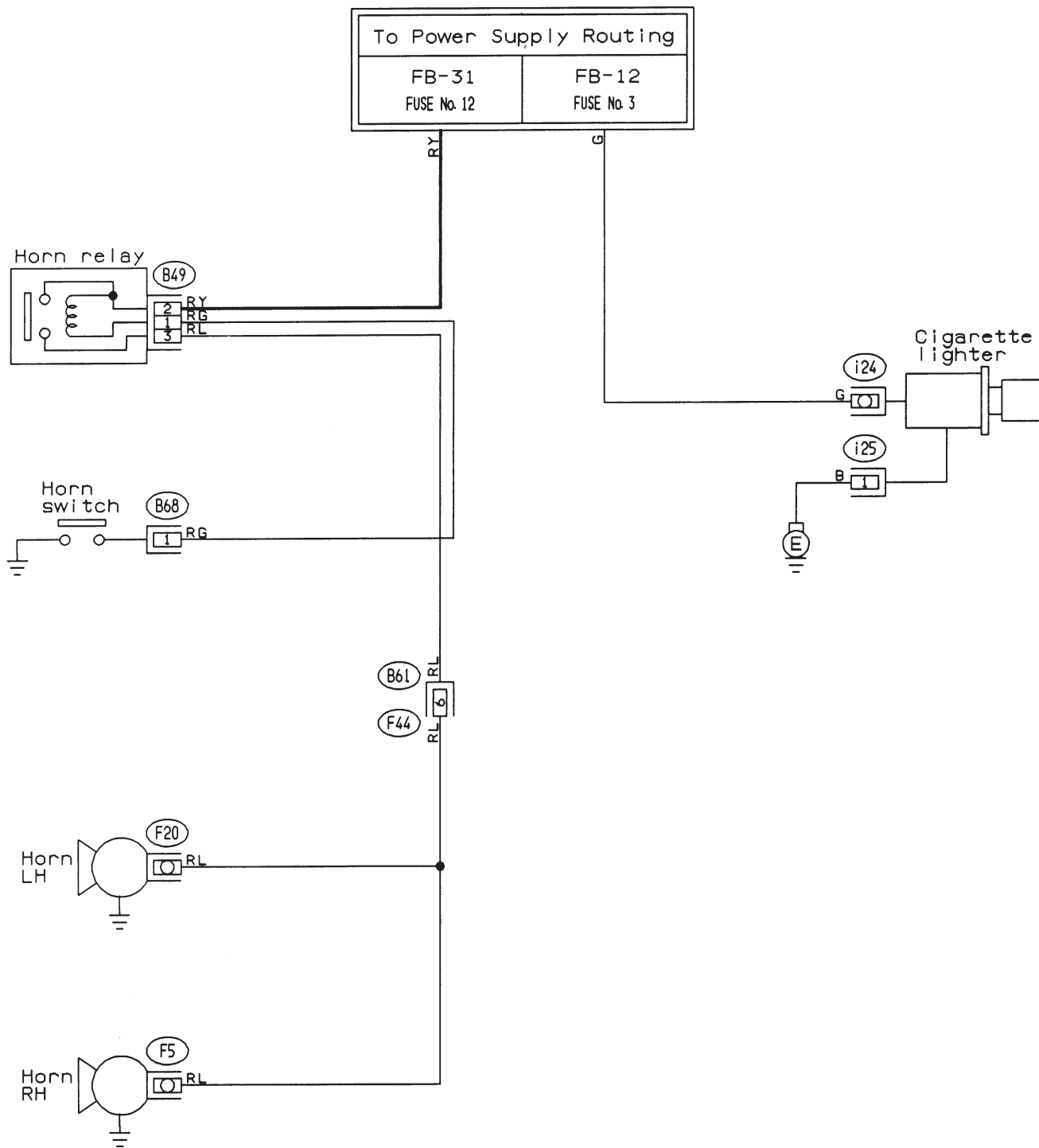

(i25) (B49) (Black)



(B68) (Black)



(F44)

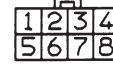

BUR74-01

P: LIGHTING SYSTEM (BACK-UP LIGHT)

1. LHD MODEL

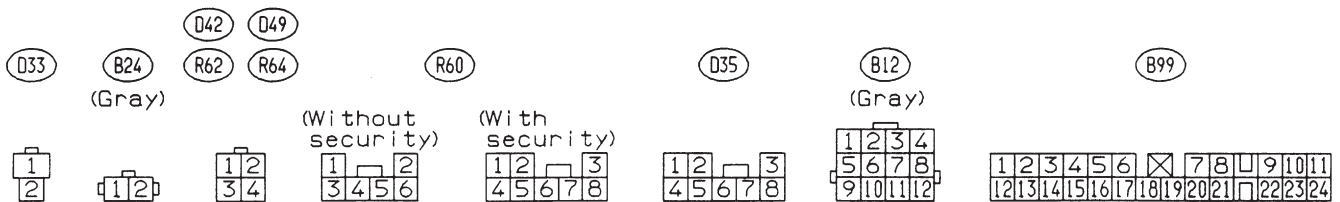
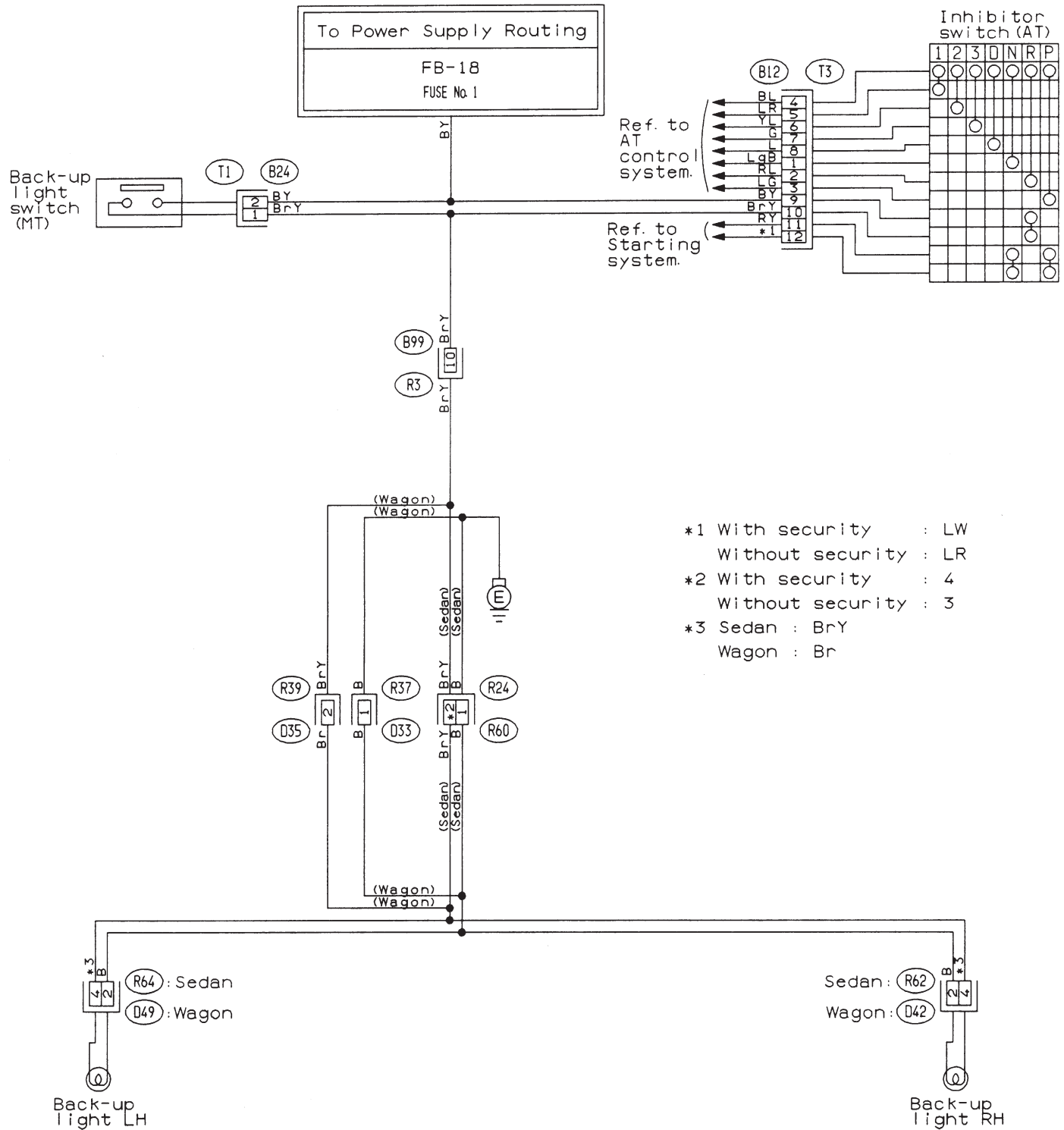

2. RHD MODEL

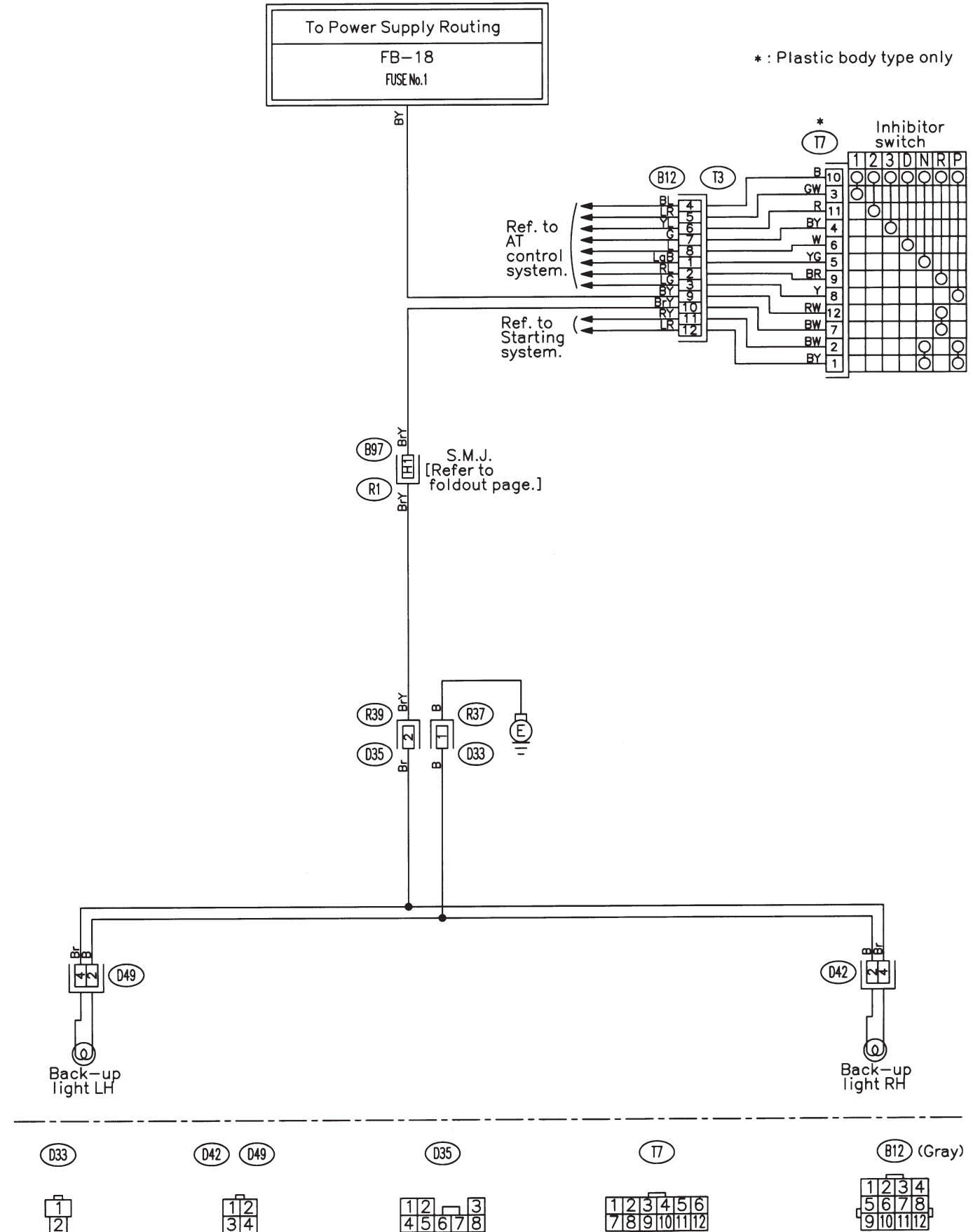

Q: LIGHTING SYSTEM (CLEARANCE LIGHT AND ILLUMINATION LIGHT)

1. LHD MODEL

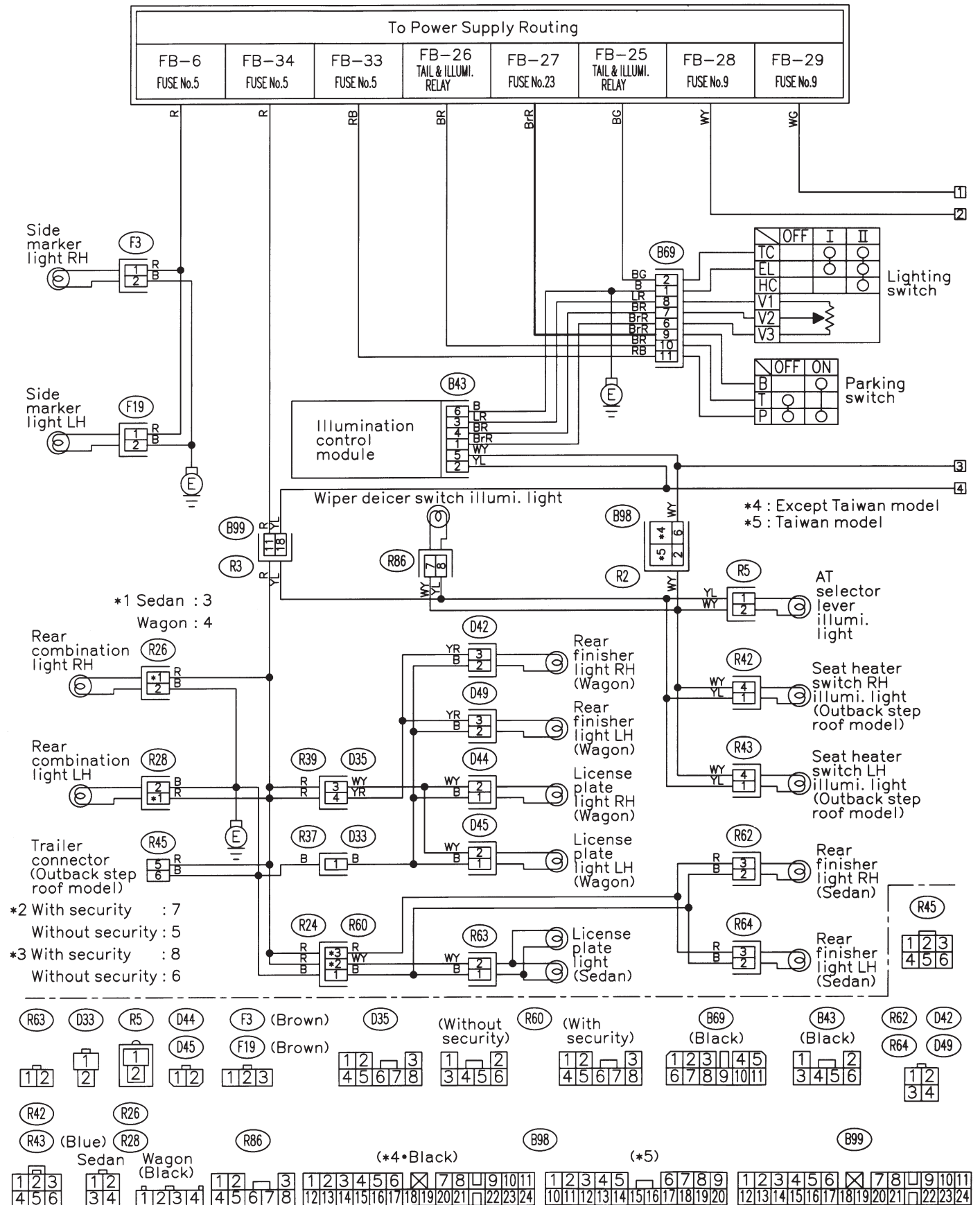

WIRING DIAGRAM

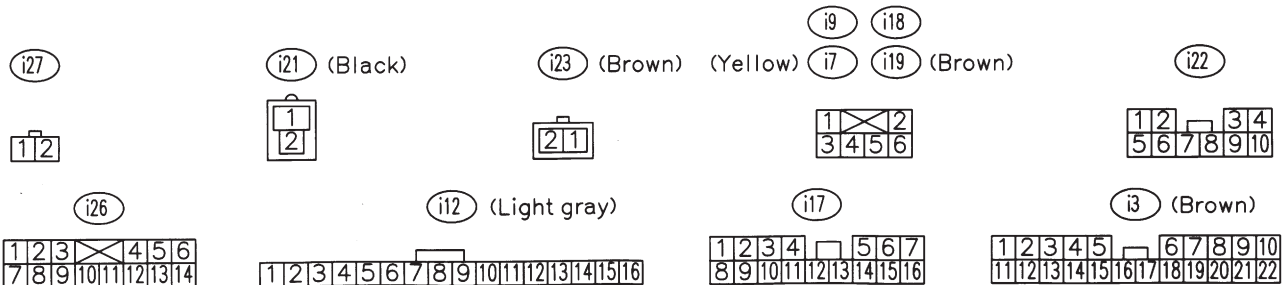
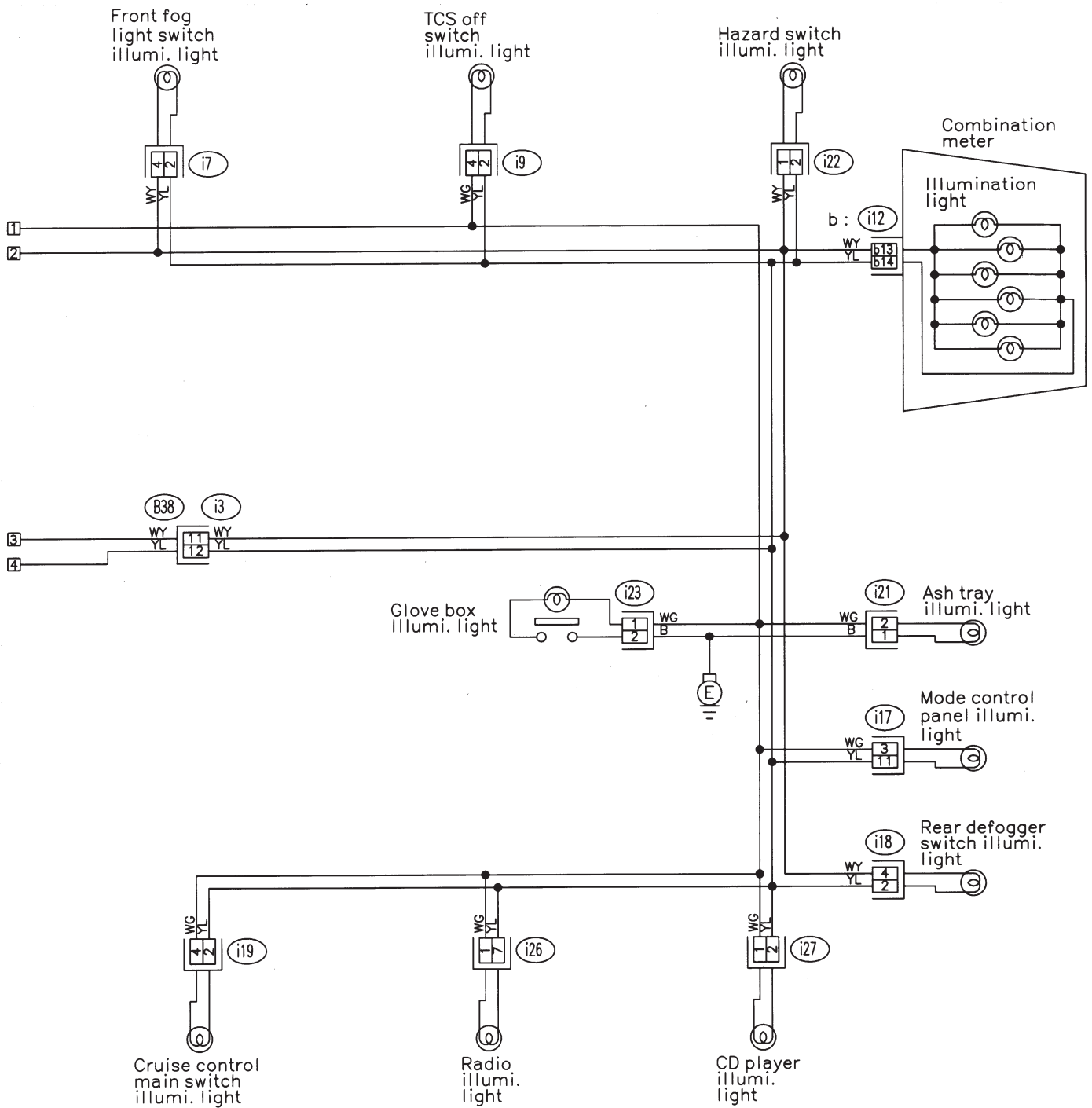

BU21-05B

WIRING DIAGRAM

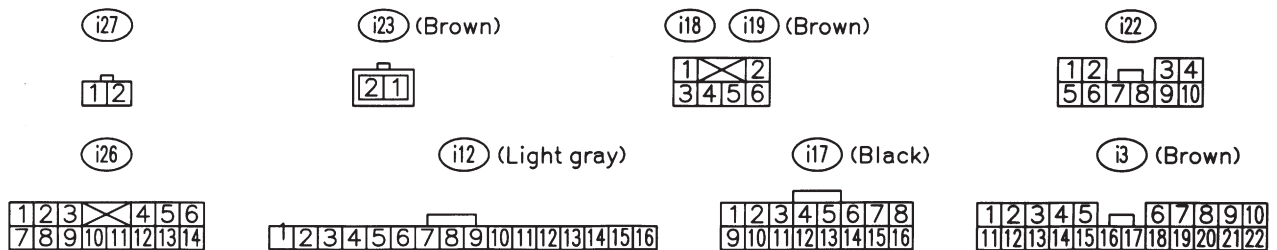
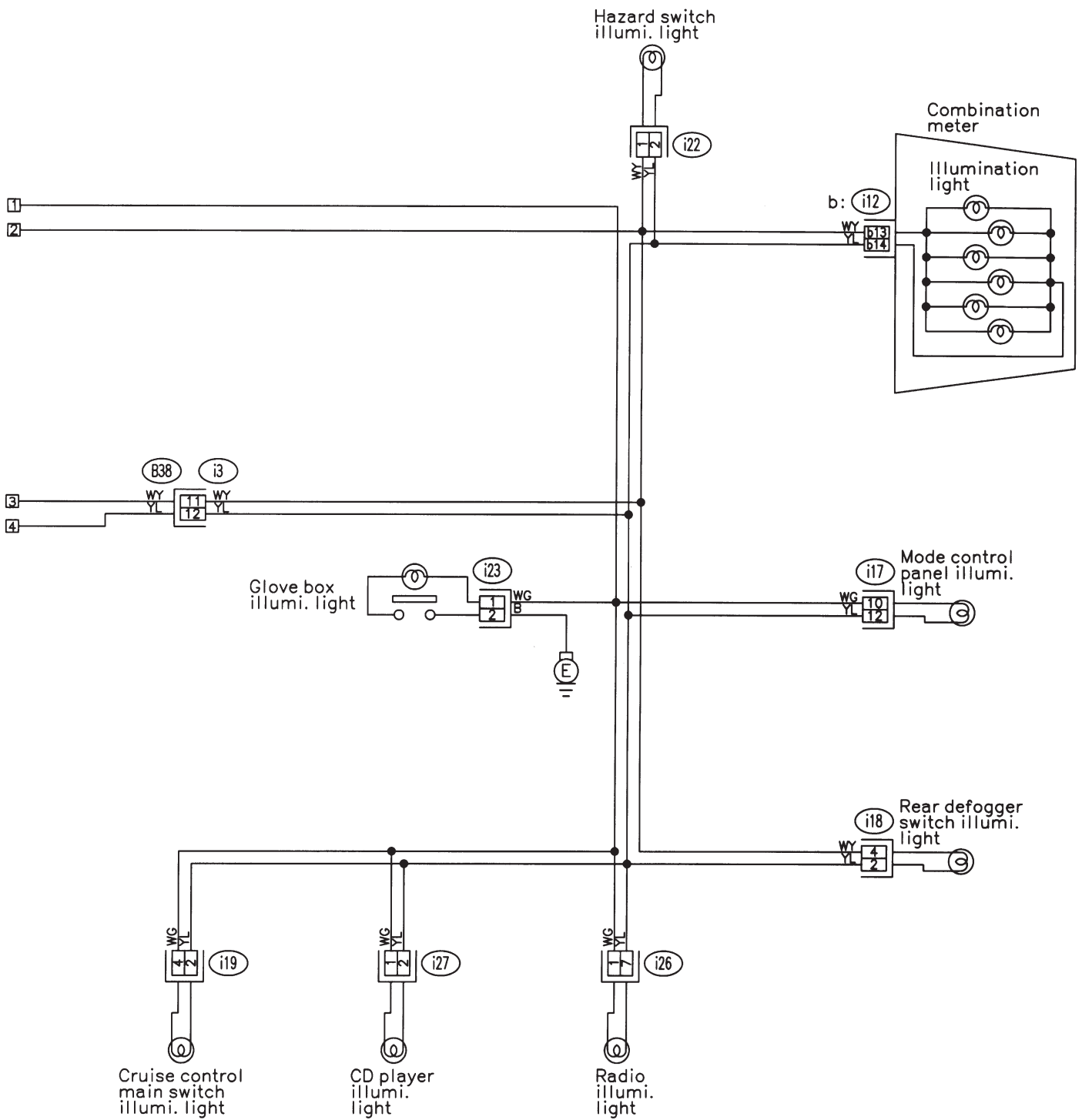

BUR21-02B

R: LIGHTING SYSTEM (FRONT FOG LIGHT)

1. WITHOUT DRL MODEL

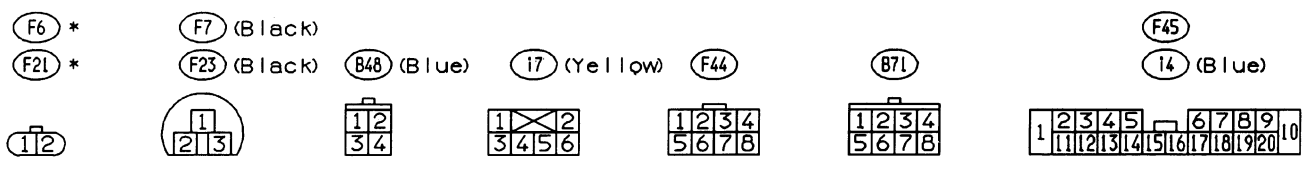
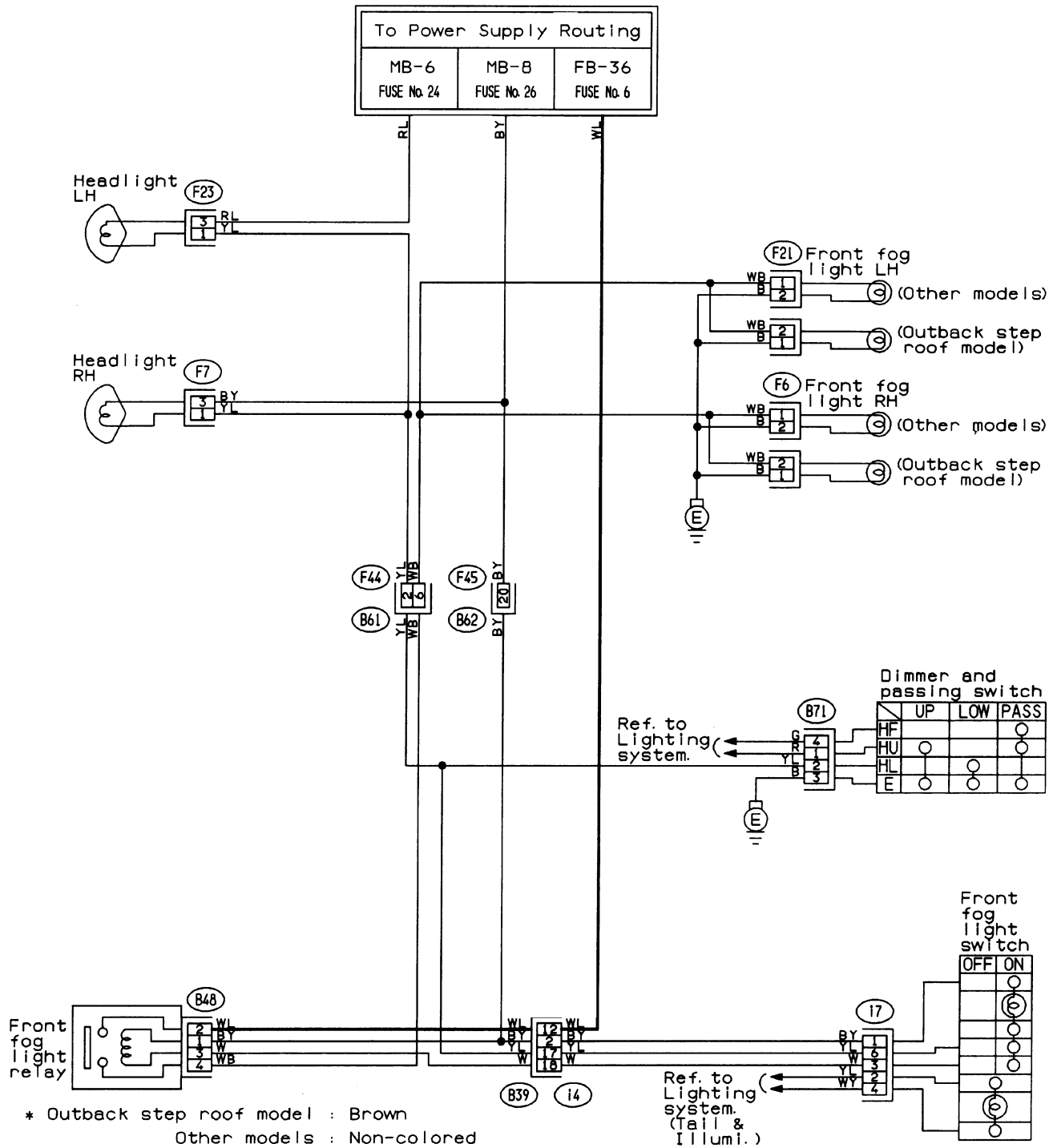

2. WITH DRL MODEL

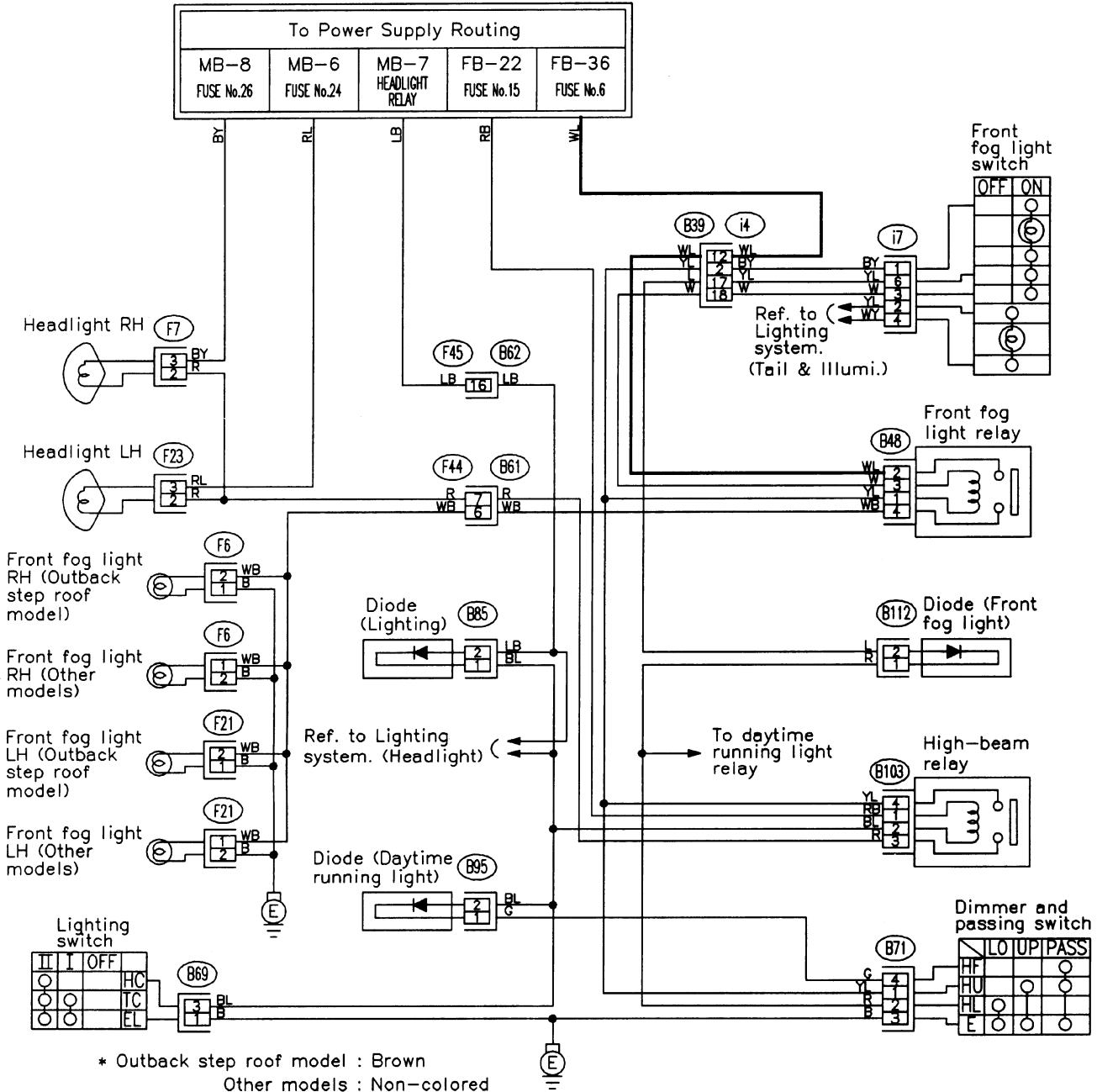

- | | | | | | |
|----------------|---------|---------------|--------------|---------------|---------------|
| (B85) (Black) | (F6) * | (F7) (Black) | (B48) (Blue) | (B103) (Blue) | (i7) (Yellow) |
| (B85) (Black) | (F21) * | (F23) (Black) | | | |
| (B112) (Black) | | | | | |
| | | | | | |
| (F44) | (B71) | (B69) (Black) | (i4) (Blue) | | |
| | | | (F45) | | |
| | | | | | |

BC22-02

MEMO:

S: LIGHTING SYSTEM (HEADLIGHT)

1. WITHOUT DRL (LHD) MODEL

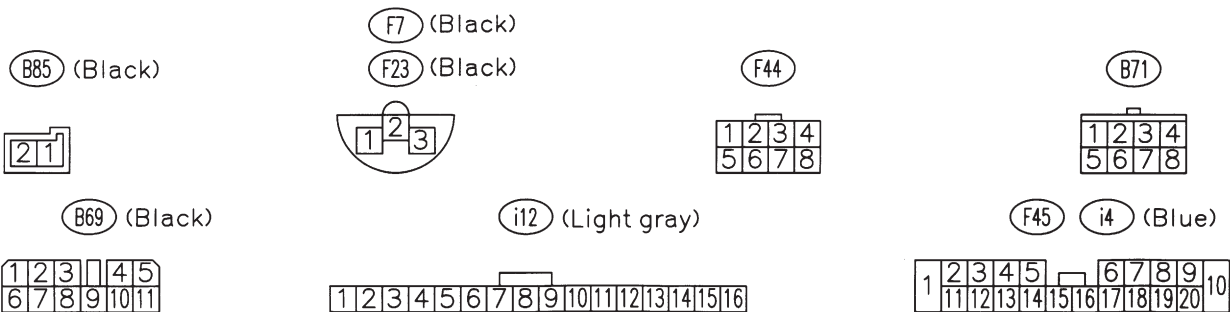
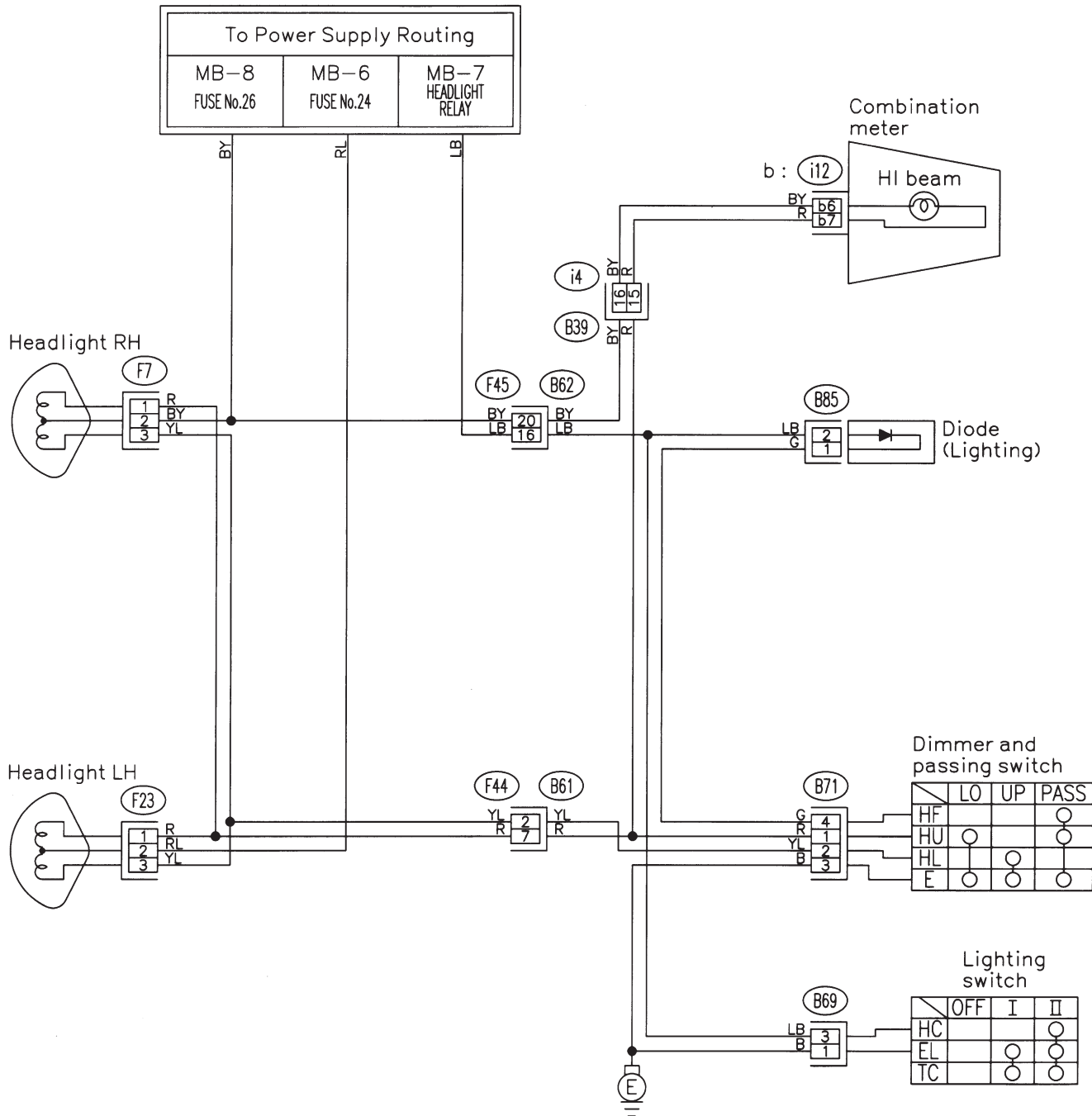

2. WITH DRL (LHD) MODEL

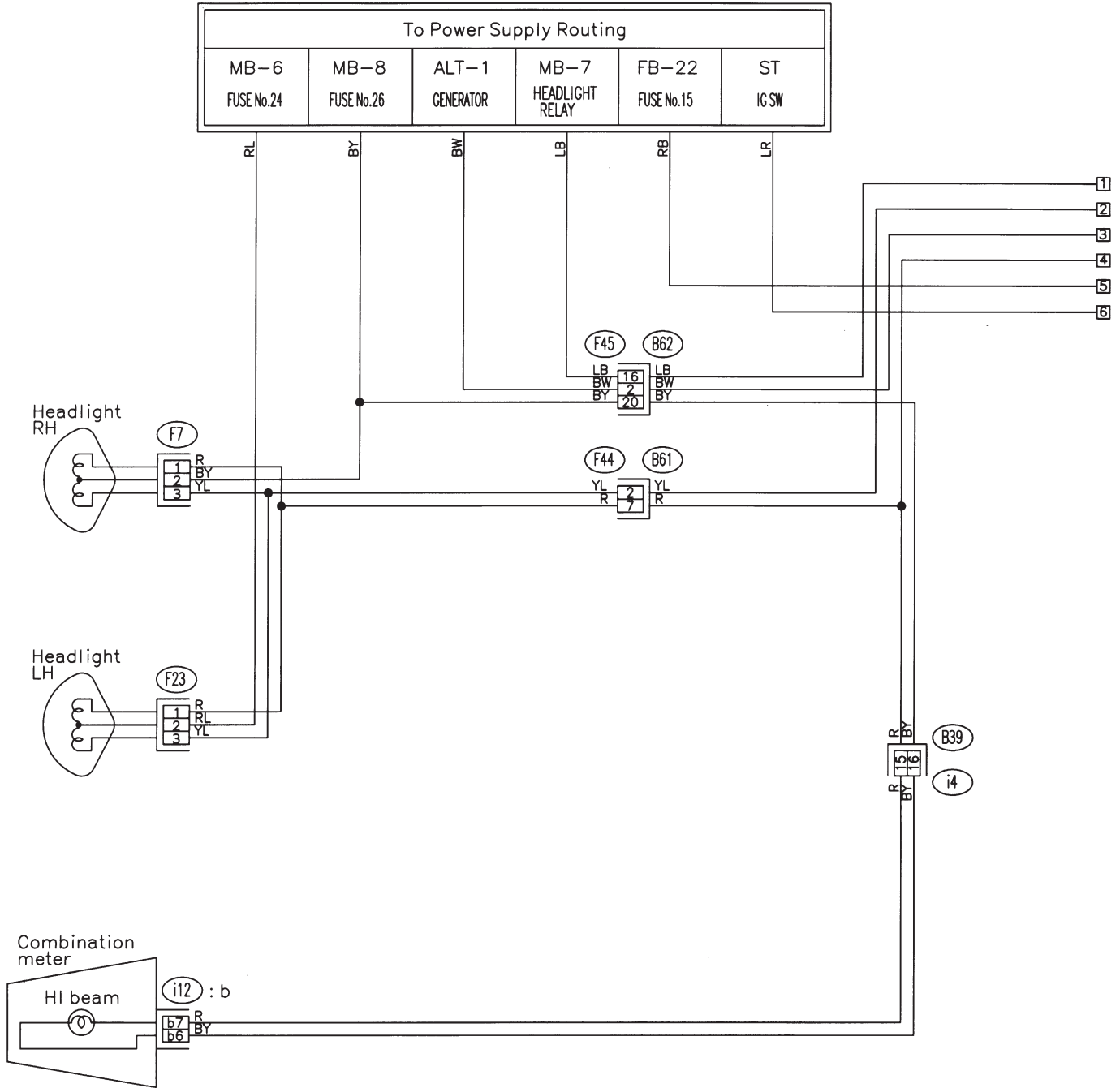

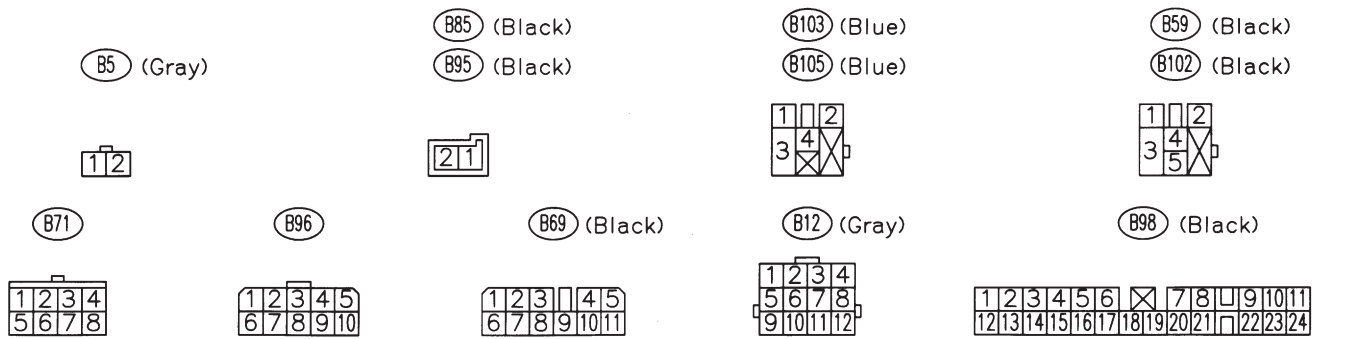
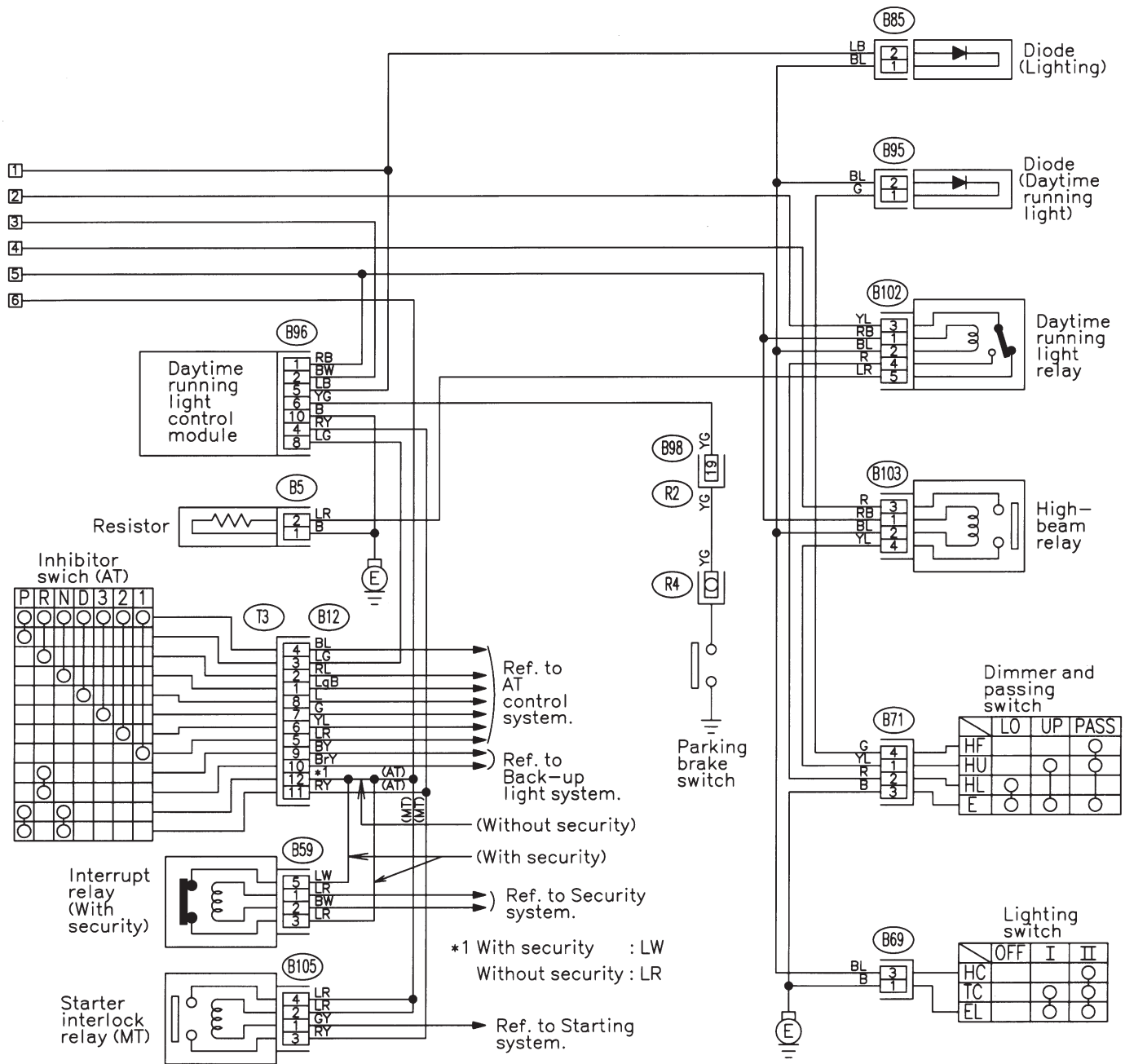

3. RHD MODEL

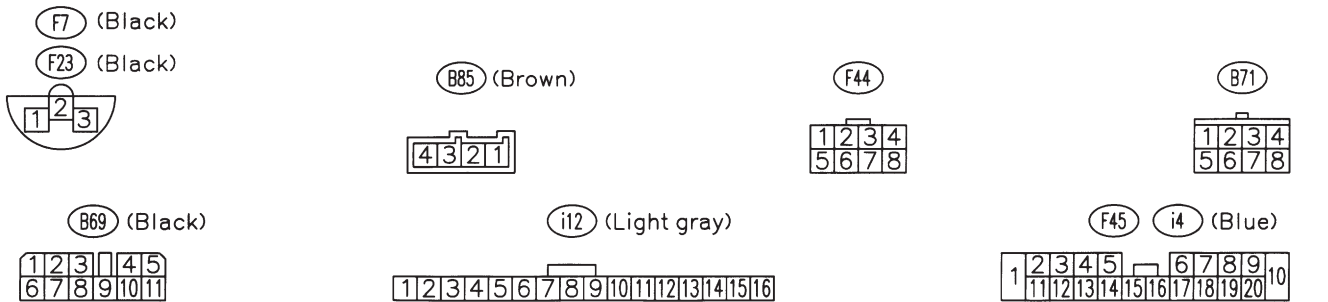
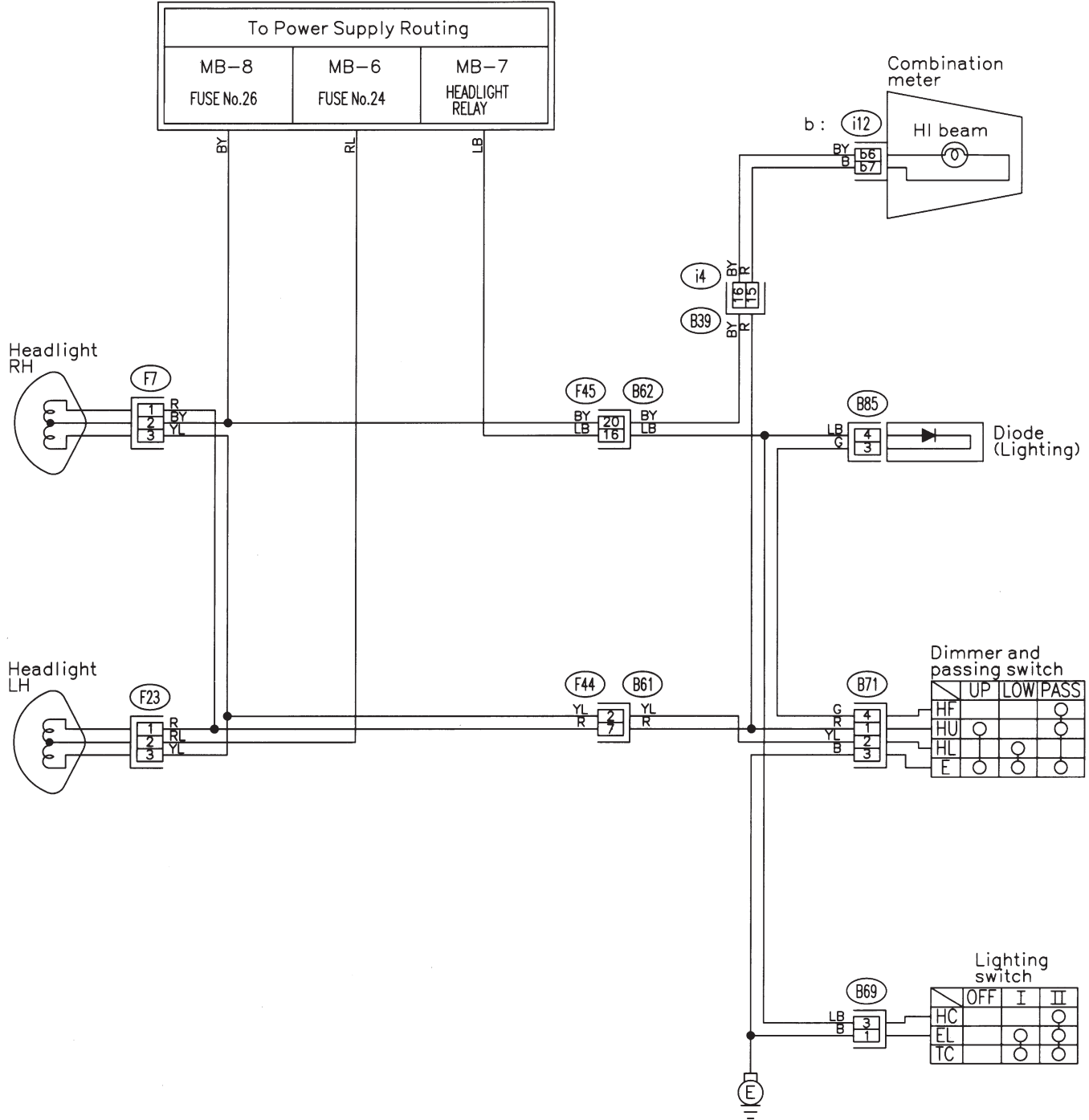

MEMO:

T: LIGHTING SYSTEM (IN COMPARTMENT)

1. LHD MODEL

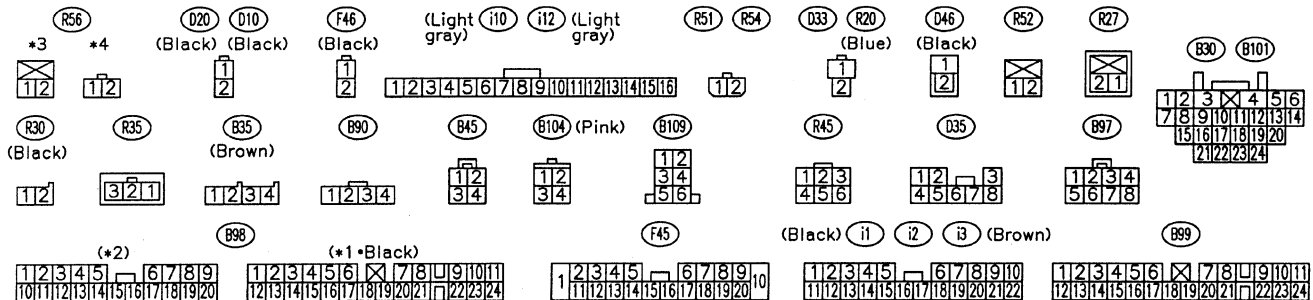
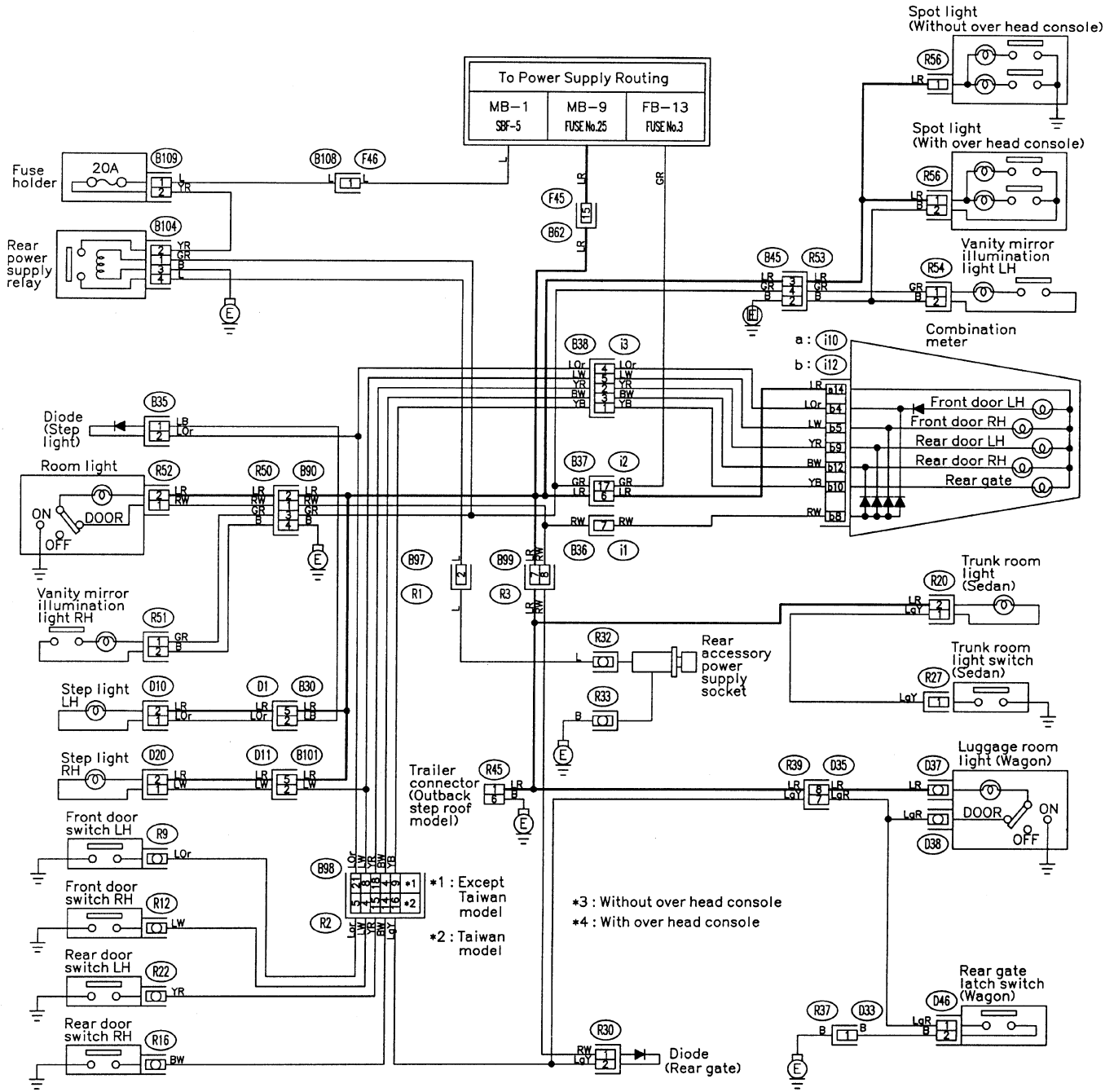

2. RHD MODEL

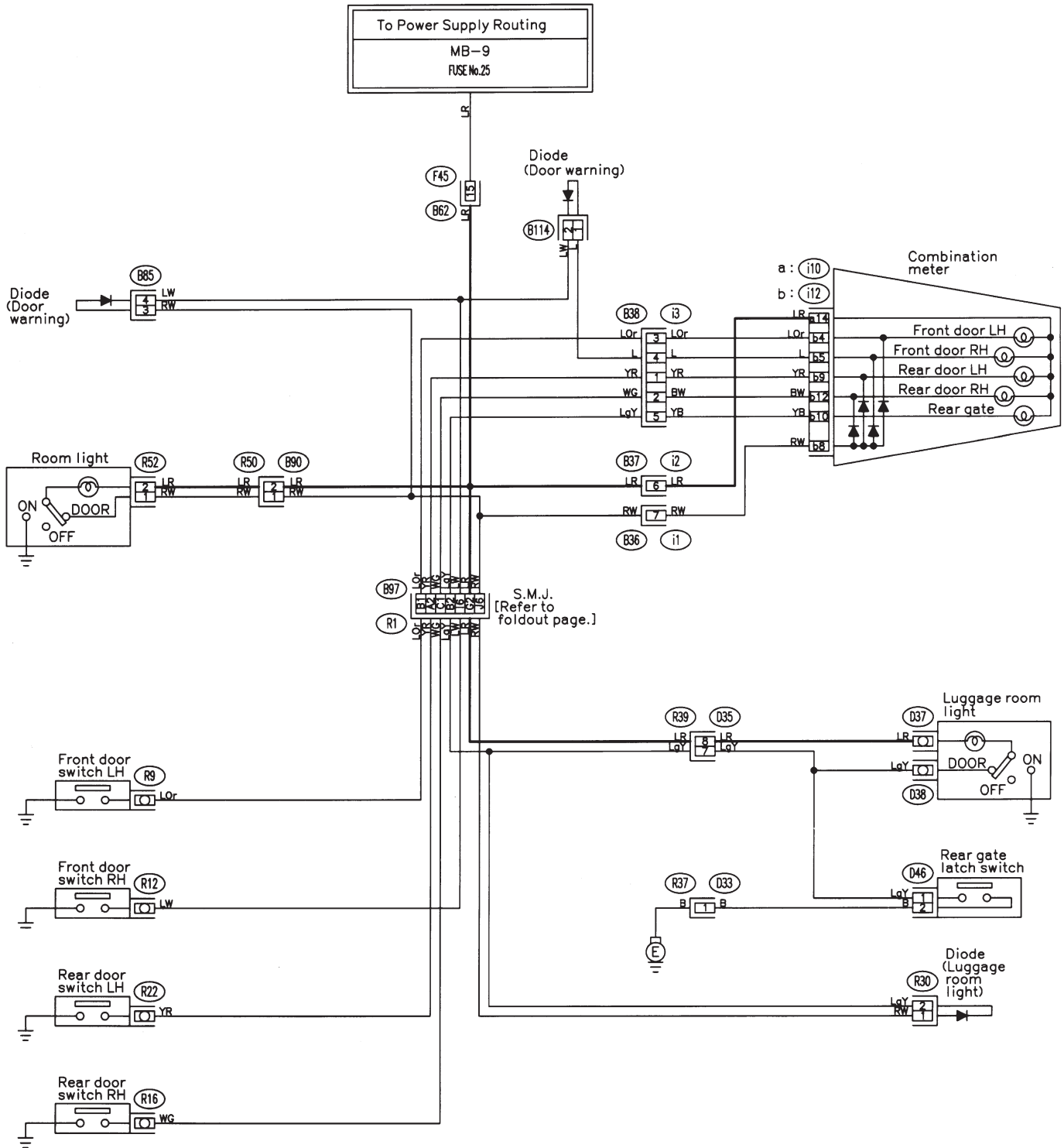

- (B114) (Black)
- (R30) (Black)
- (D33) (Green)
- (B90) (Green)
- (D46) (Black)
- (R52)
- (B85) (Brown)
- (D35)
- (Light gray) (i10) (i12) (Light gray)
- (F45)
- (Black) (i1) (i2)
- (i3) (Brown)



U: LIGHTING SYSTEM (STOP LIGHT)

1. LHD MODEL

- *1 : Without cruise control
- *2 : With cruise control
- *3 : With TCS
- *4 : Sedan
- *5 : Wagon

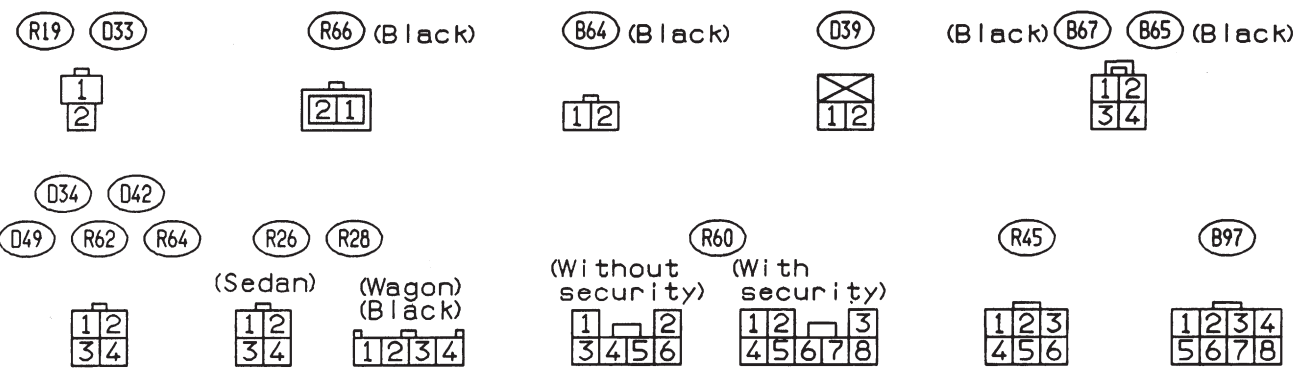
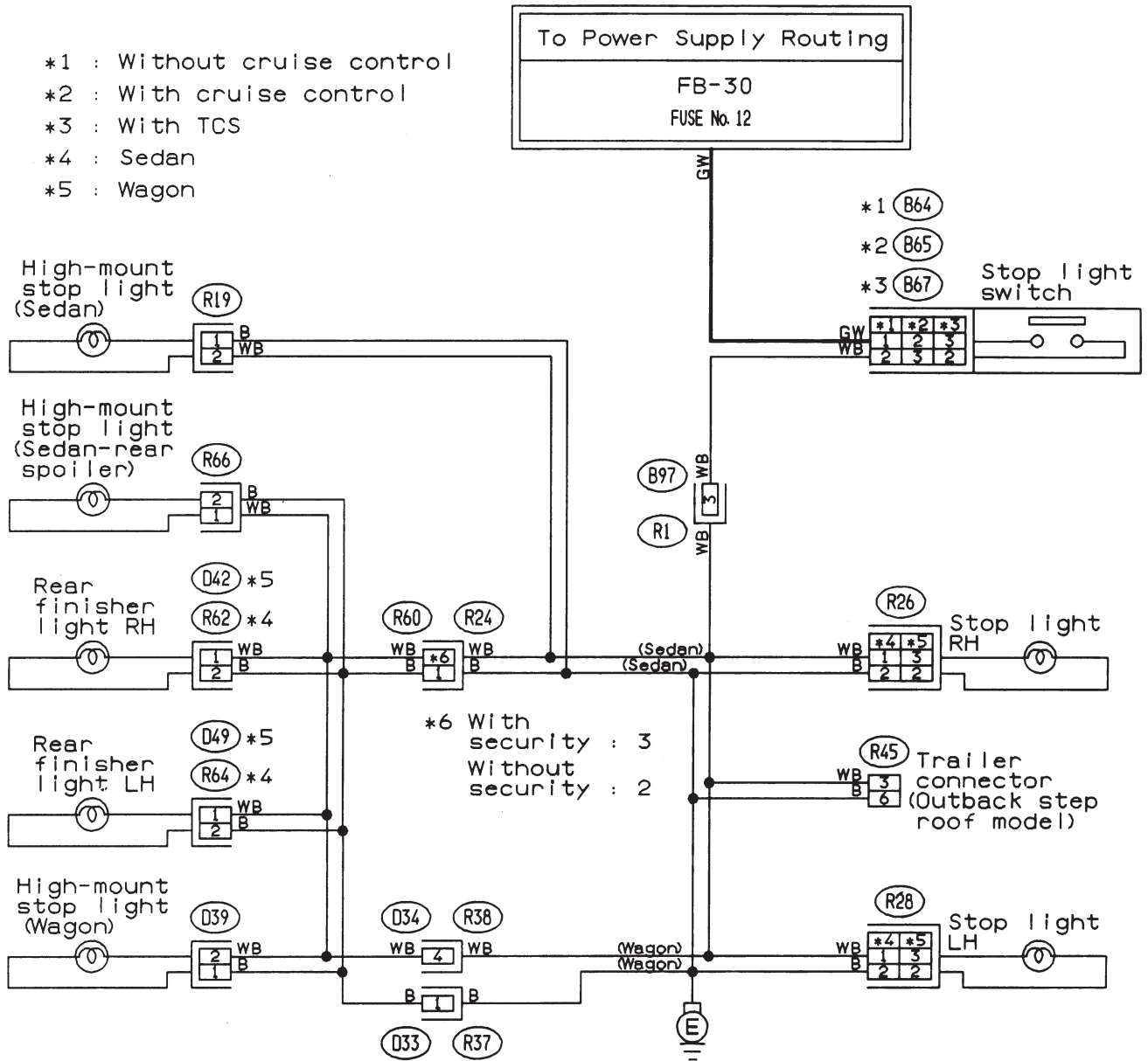

BU25-03

2. RHD MODEL

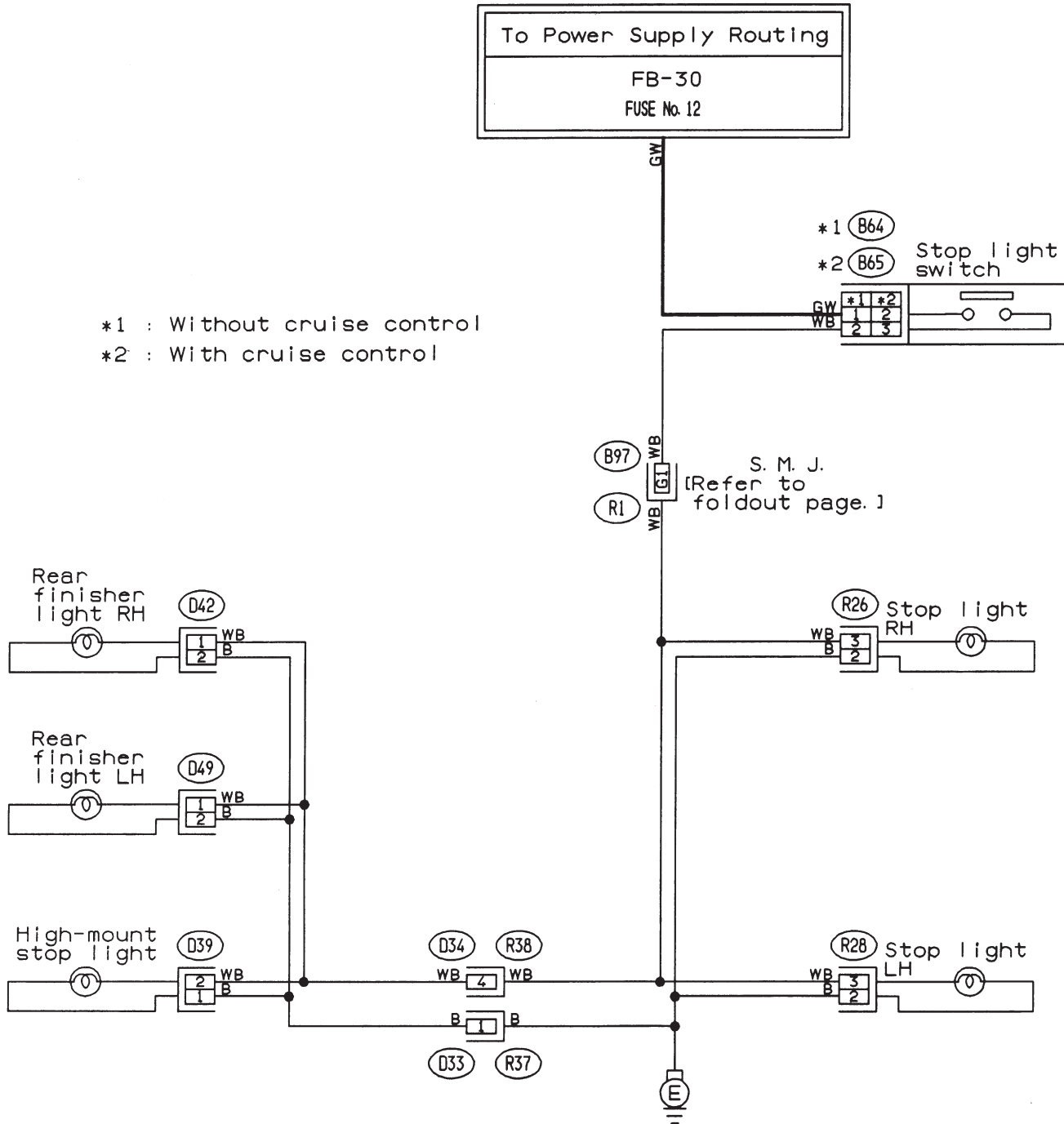

*1 : Without cruise control
*2 : With cruise control

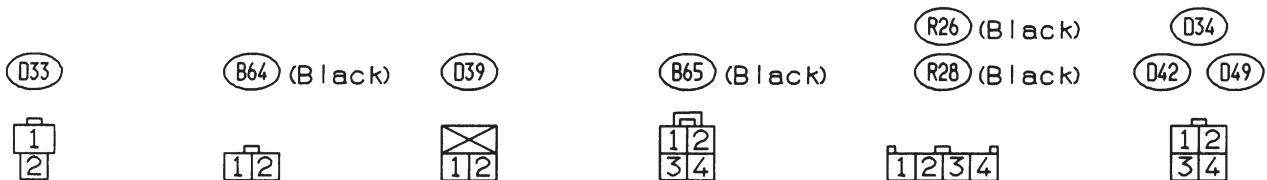

BUR25-01

V: LIGHTING SYSTEM (TURN SIGNAL LIGHT AND HAZARD LIGHT)

1. LHD MODEL

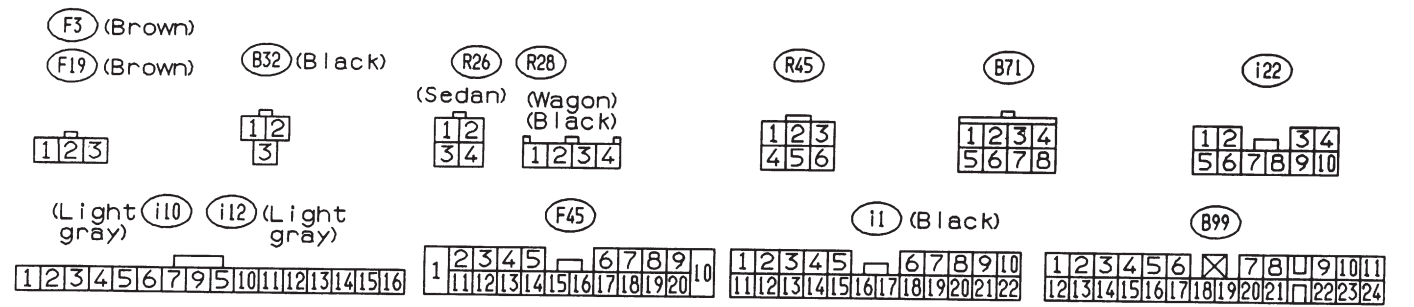
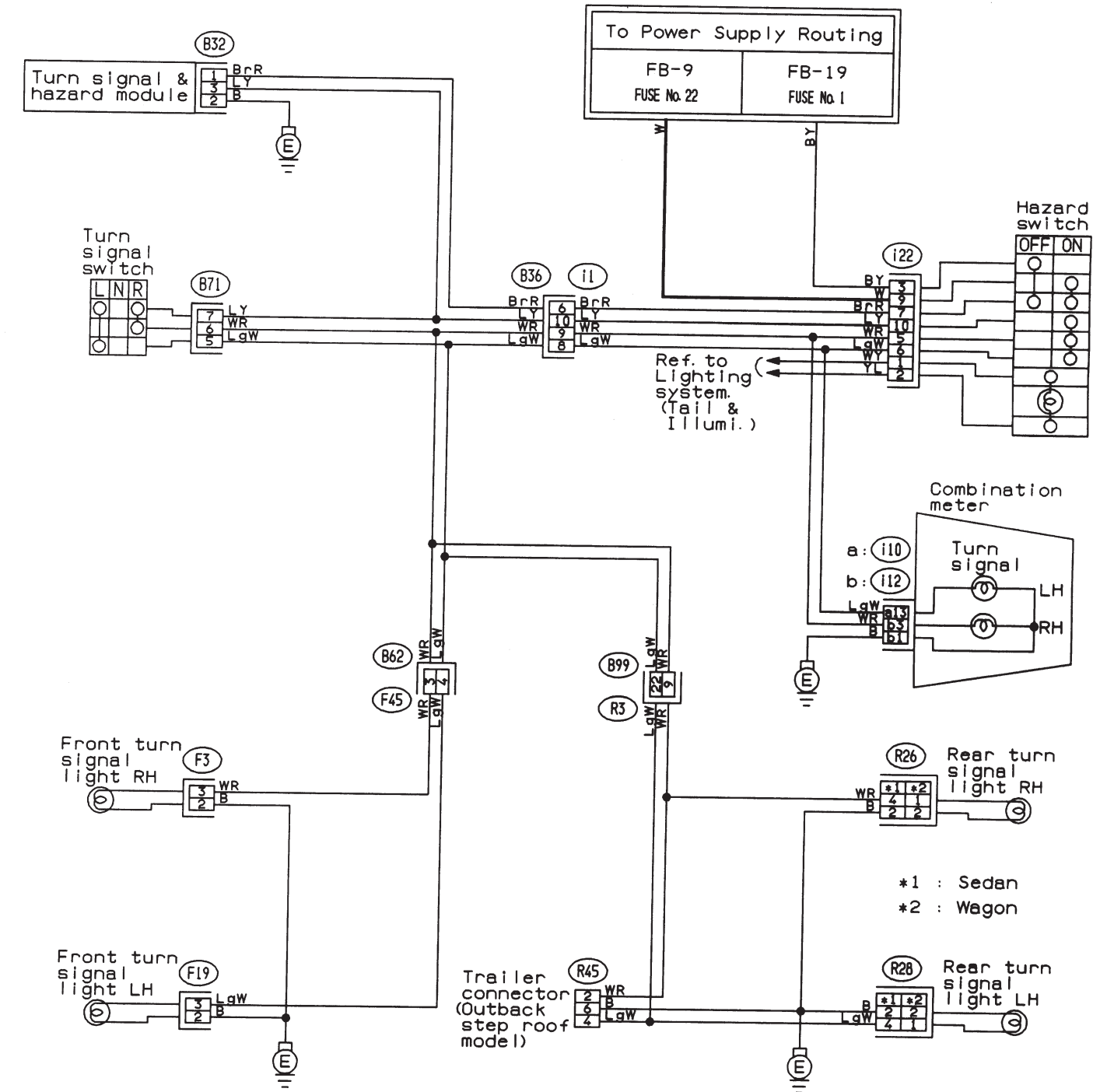

2. RHD MODEL

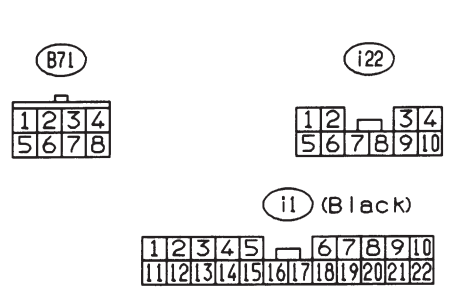
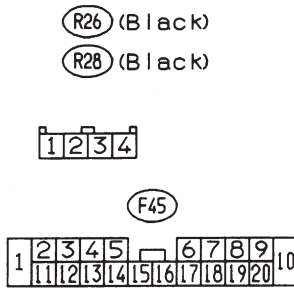
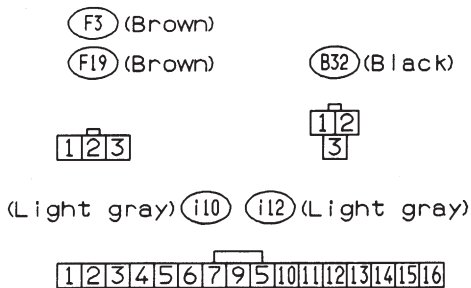
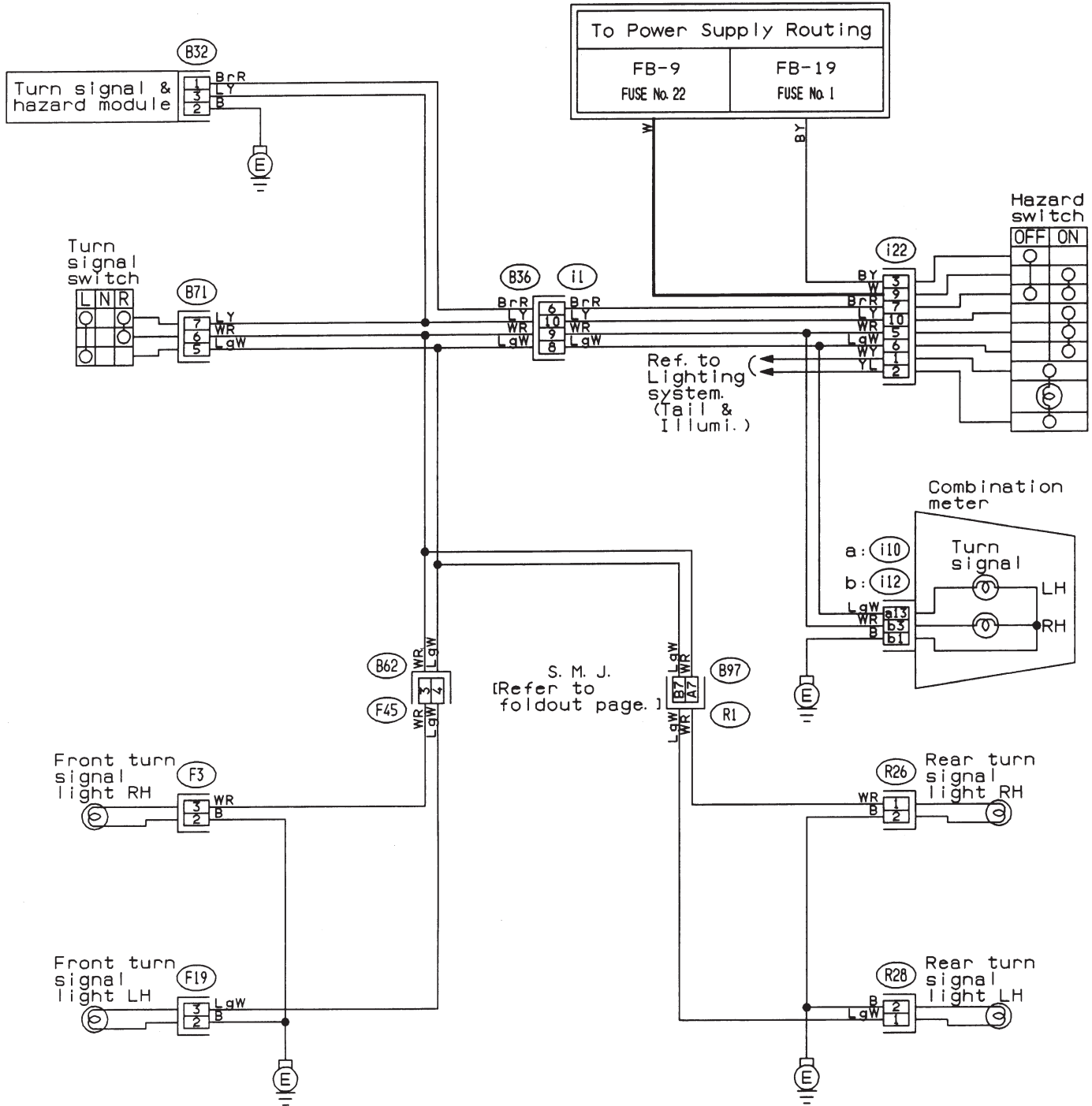

MEMO:

X: PARKING BRAKE AND BRAKE FLUID LEVEL WARNING SYSTEM

1. LHD MODEL

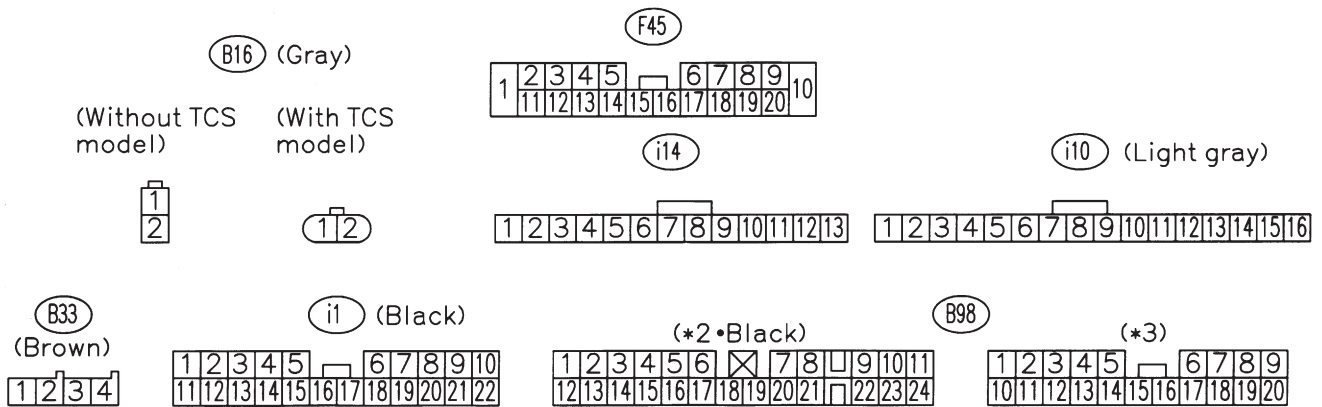
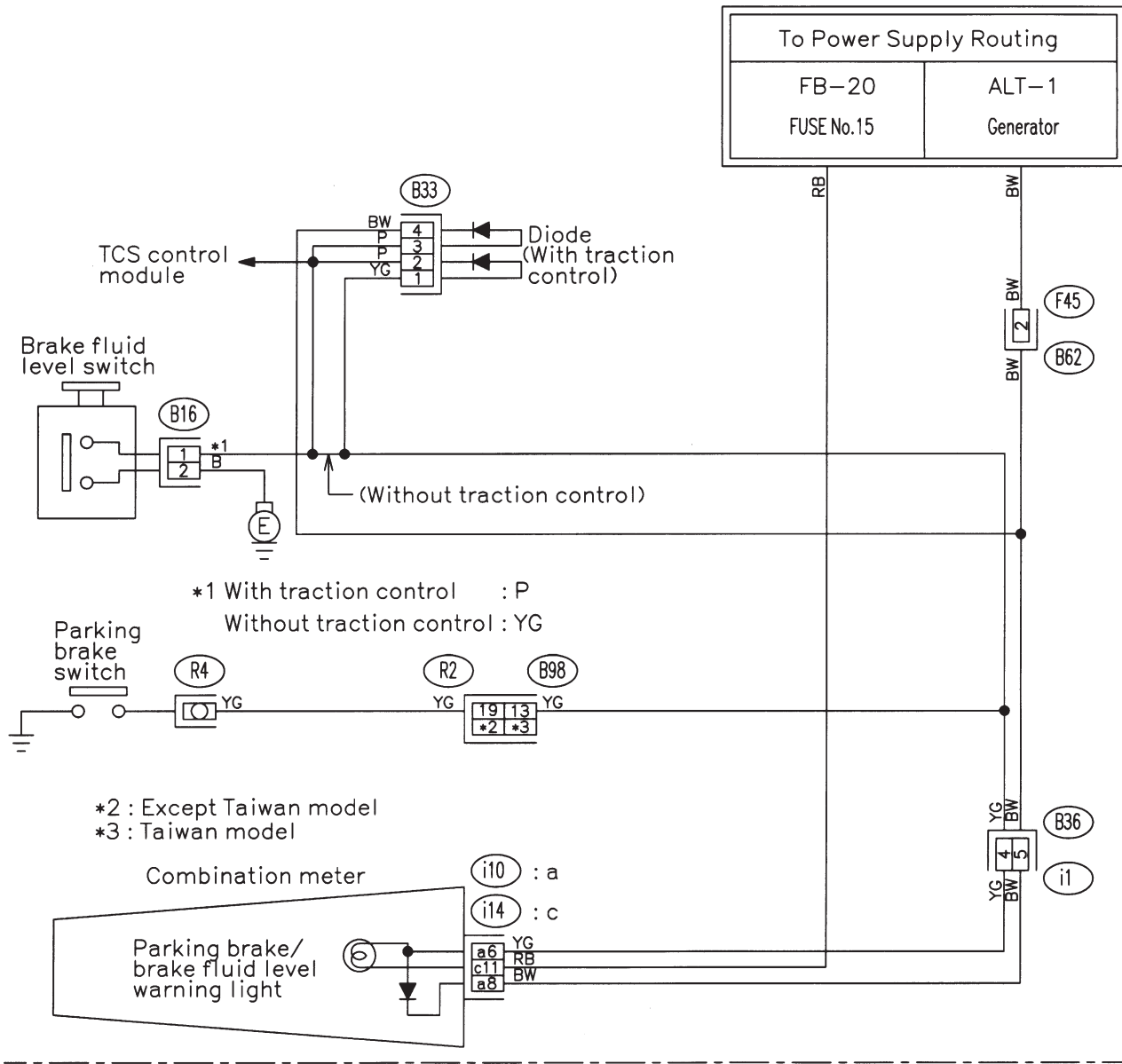

2. RHD MODEL

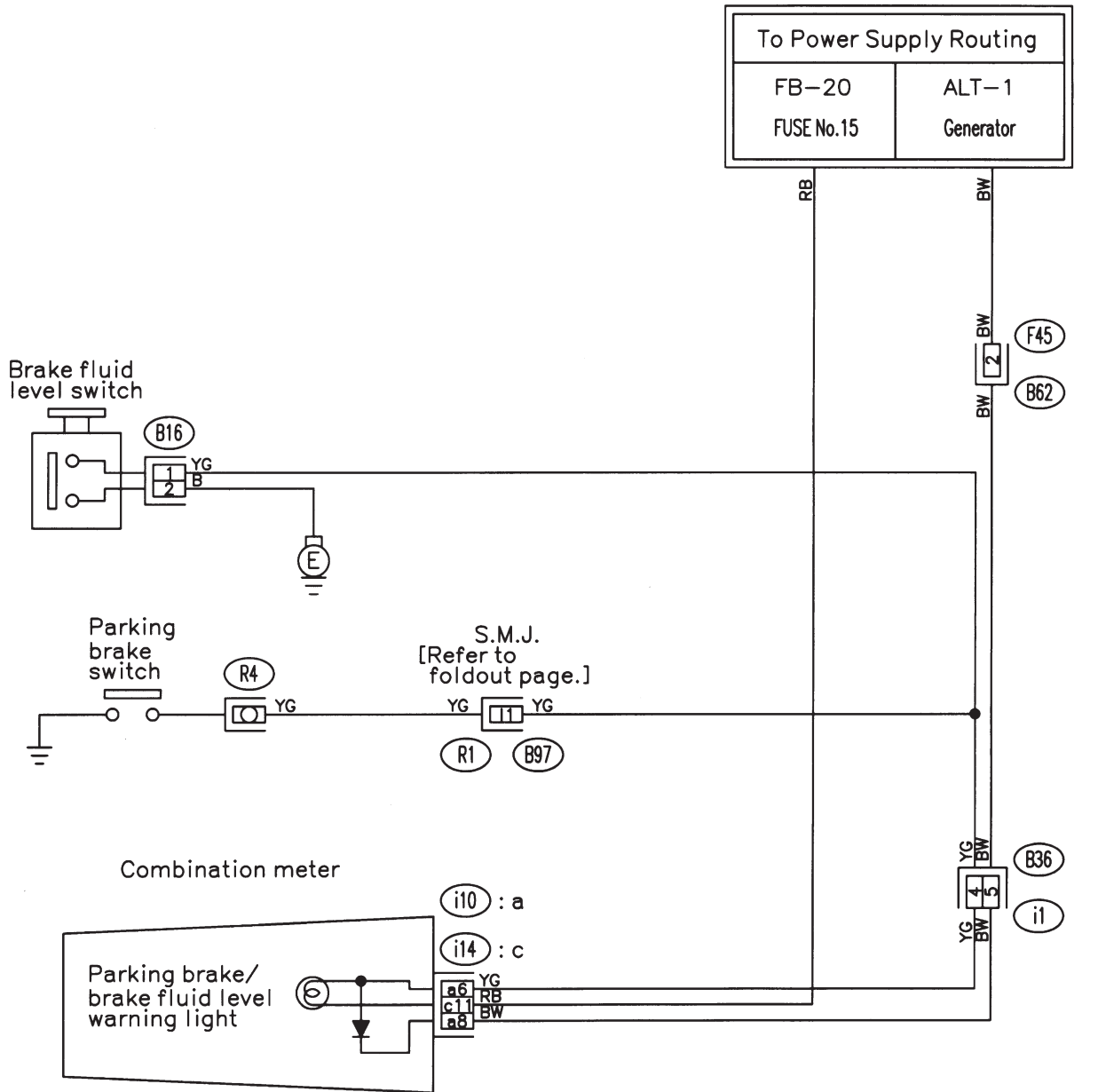

(B16) (Gray)



(i14)

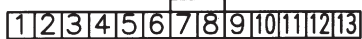

(i10) (Light gray)

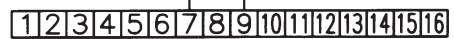

(F45)



(i) (Black)



BUR60-02

Y: POWER WINDOW SYSTEM

1. LHD MODEL

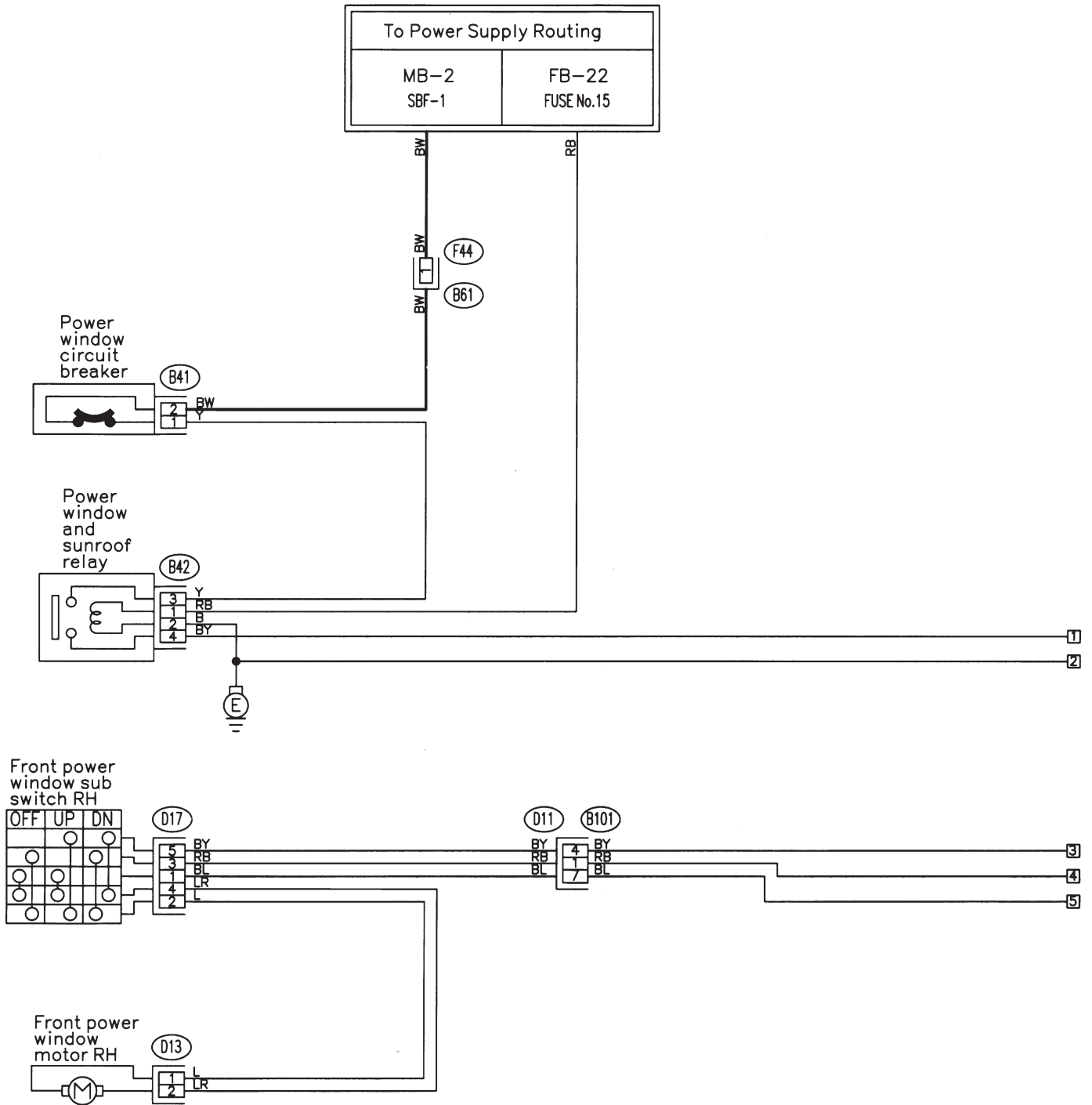

(Green) (B41)
(Green) (D3) (D13) (Green)
(Green) (D30) (D24) (Green)

(B42)

(F44)

(B30) (B101)

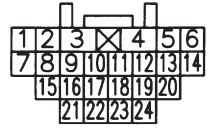
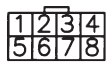
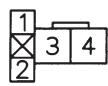

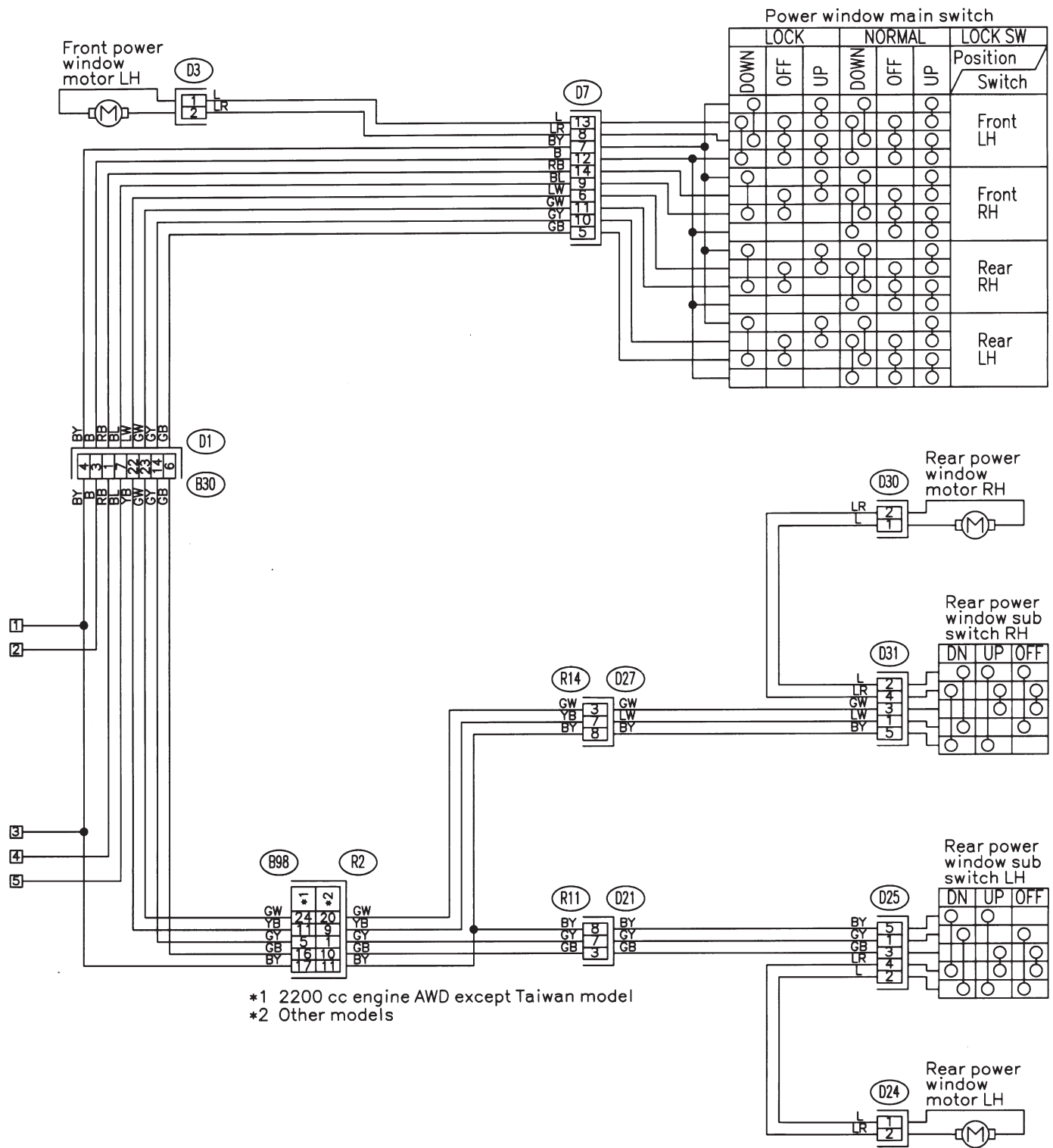

*1 2200 cc engine AWD except Taiwan model
*2 Other models

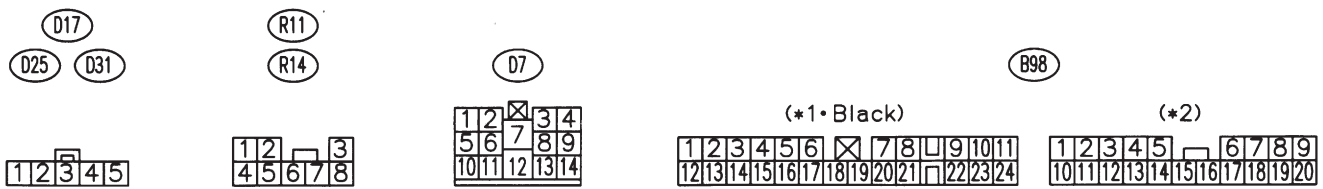

2. RHD MODEL

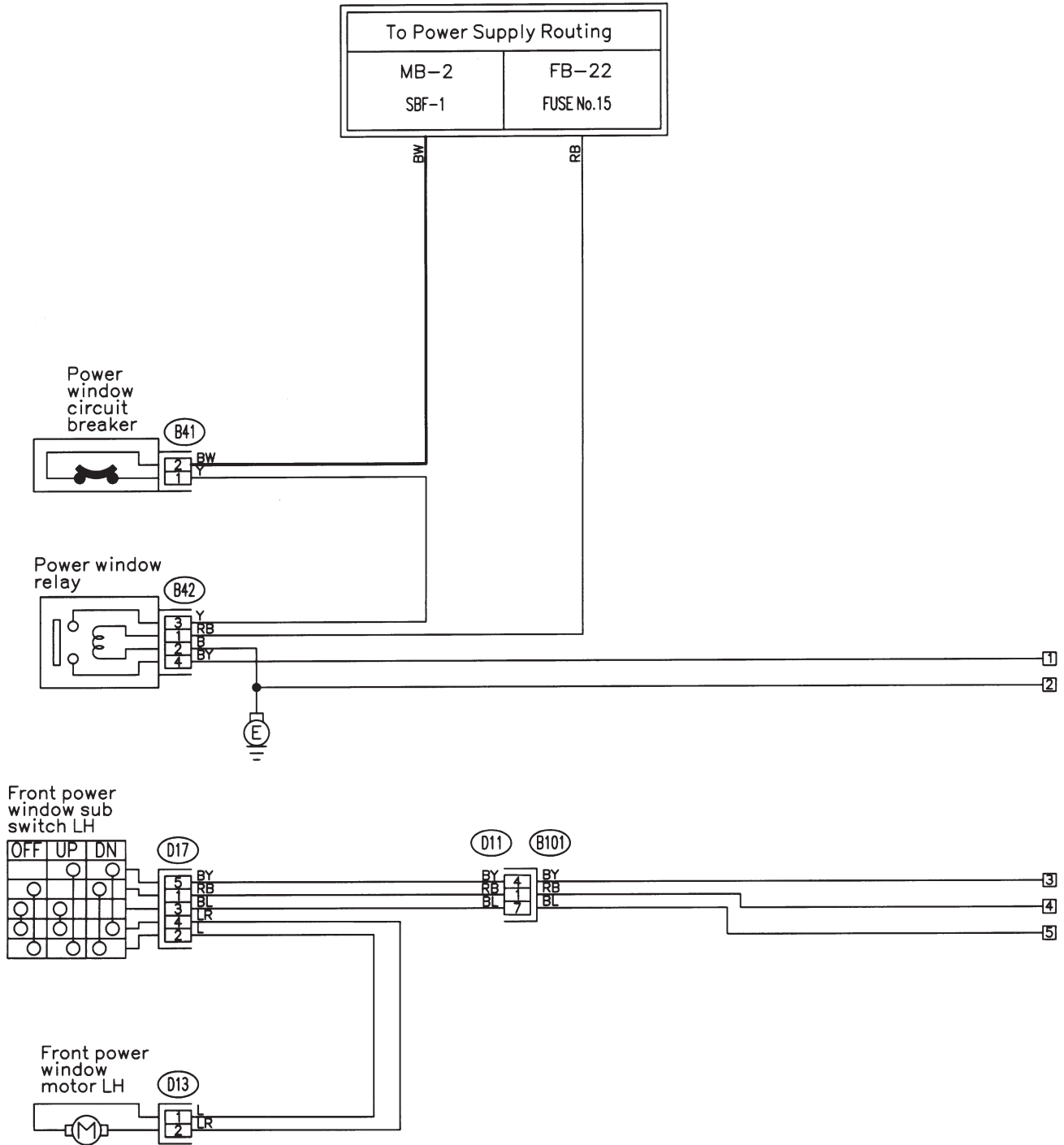

(Green) (B41)
(Green) (D3) (D13) (Green)
(Green) (D30) (D24) (Green)

(B42)

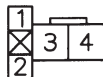
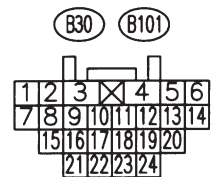

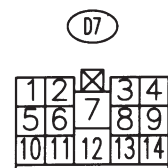
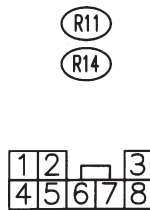
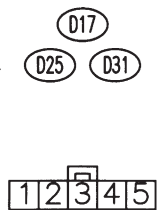
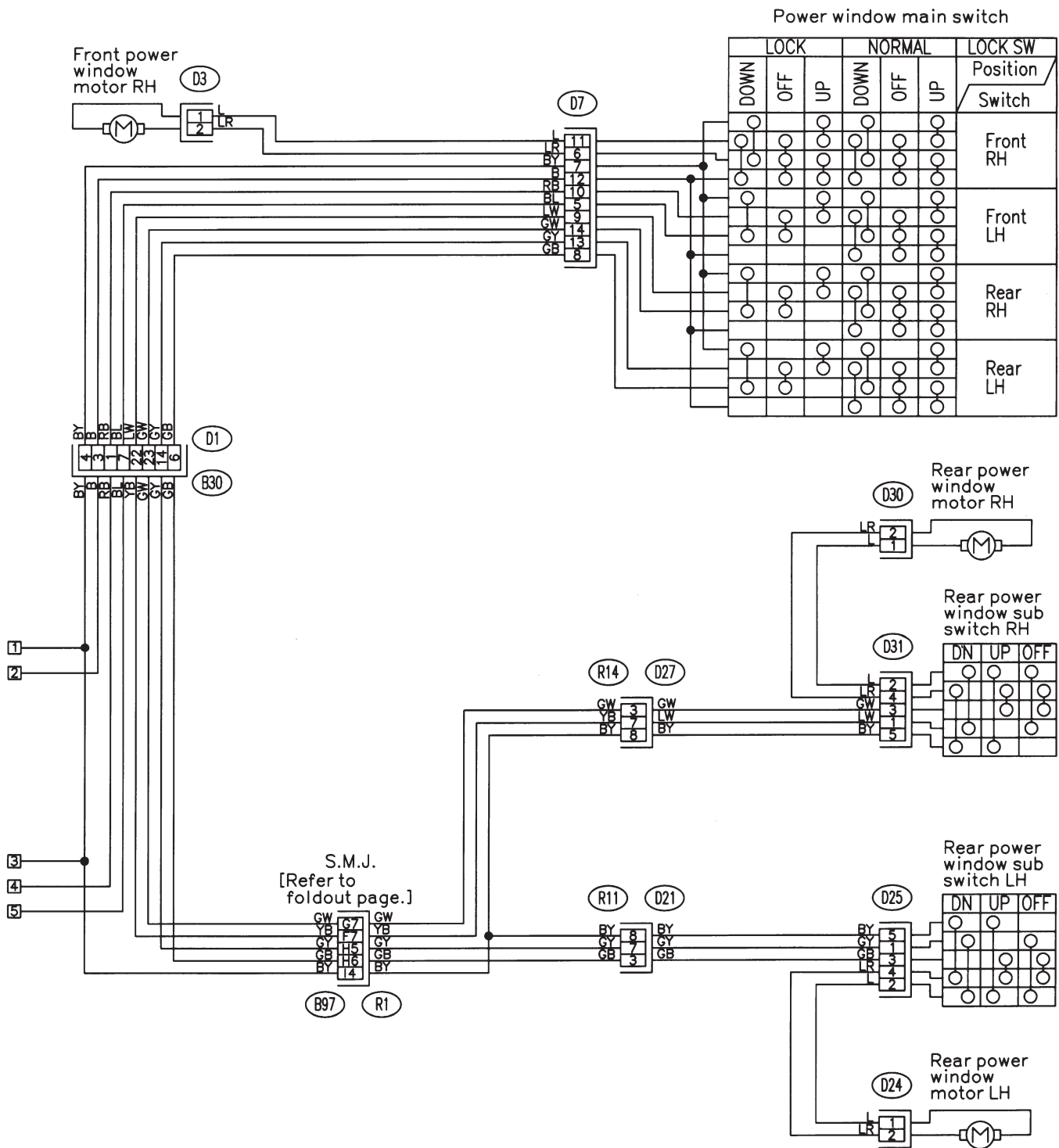

BUR70-02B

Z: RADIATOR FAN SYSTEM

1. LHD MODEL

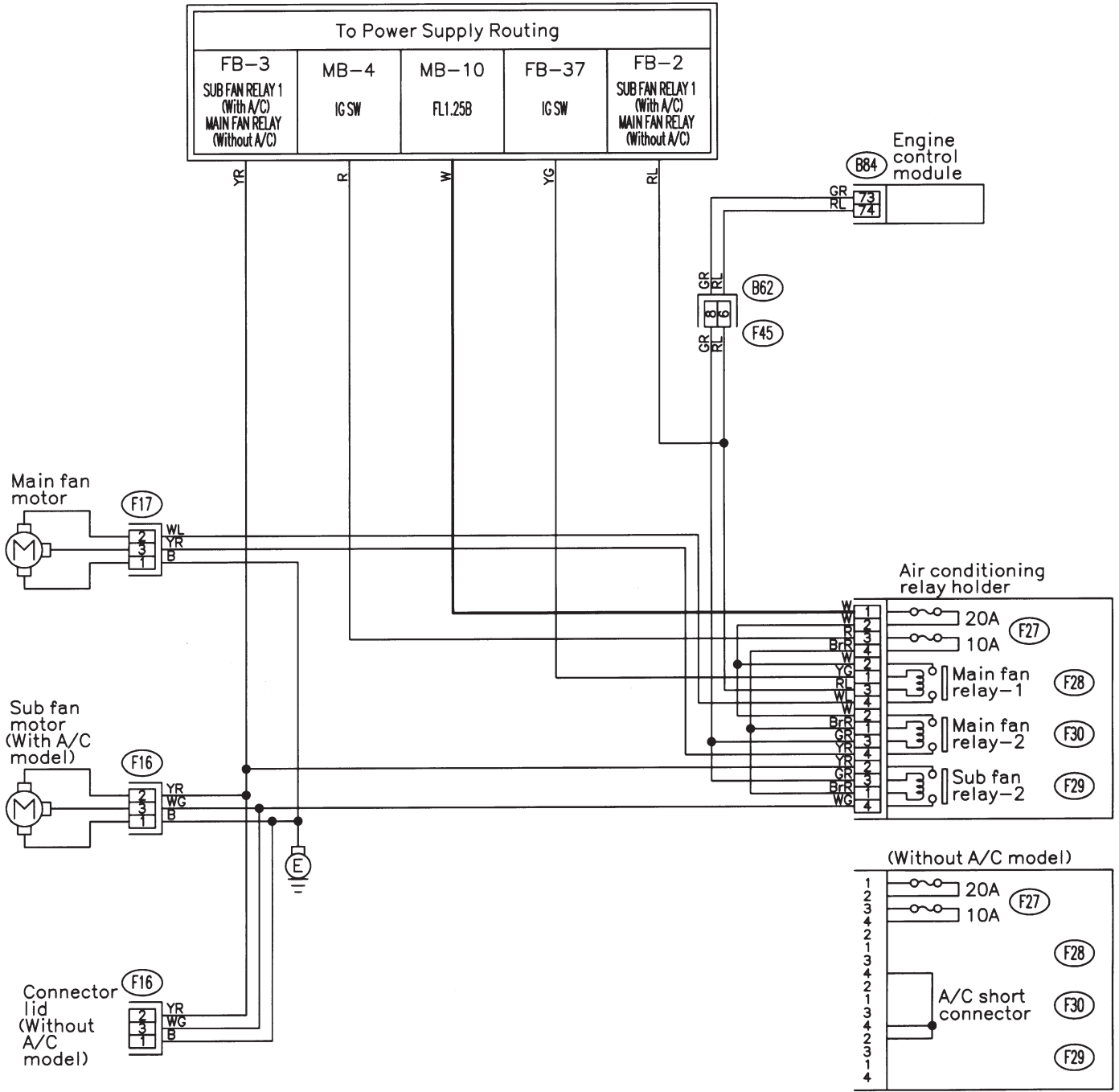

F16 (Black)

F17 (Black)

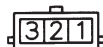

F45

B84 (Light blue)

F27 F28 F29 F30 F31

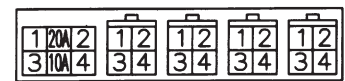

A/C relay holder (Black)

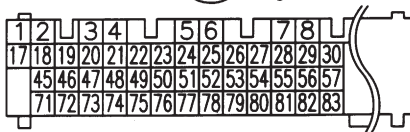

2. RHD MODEL

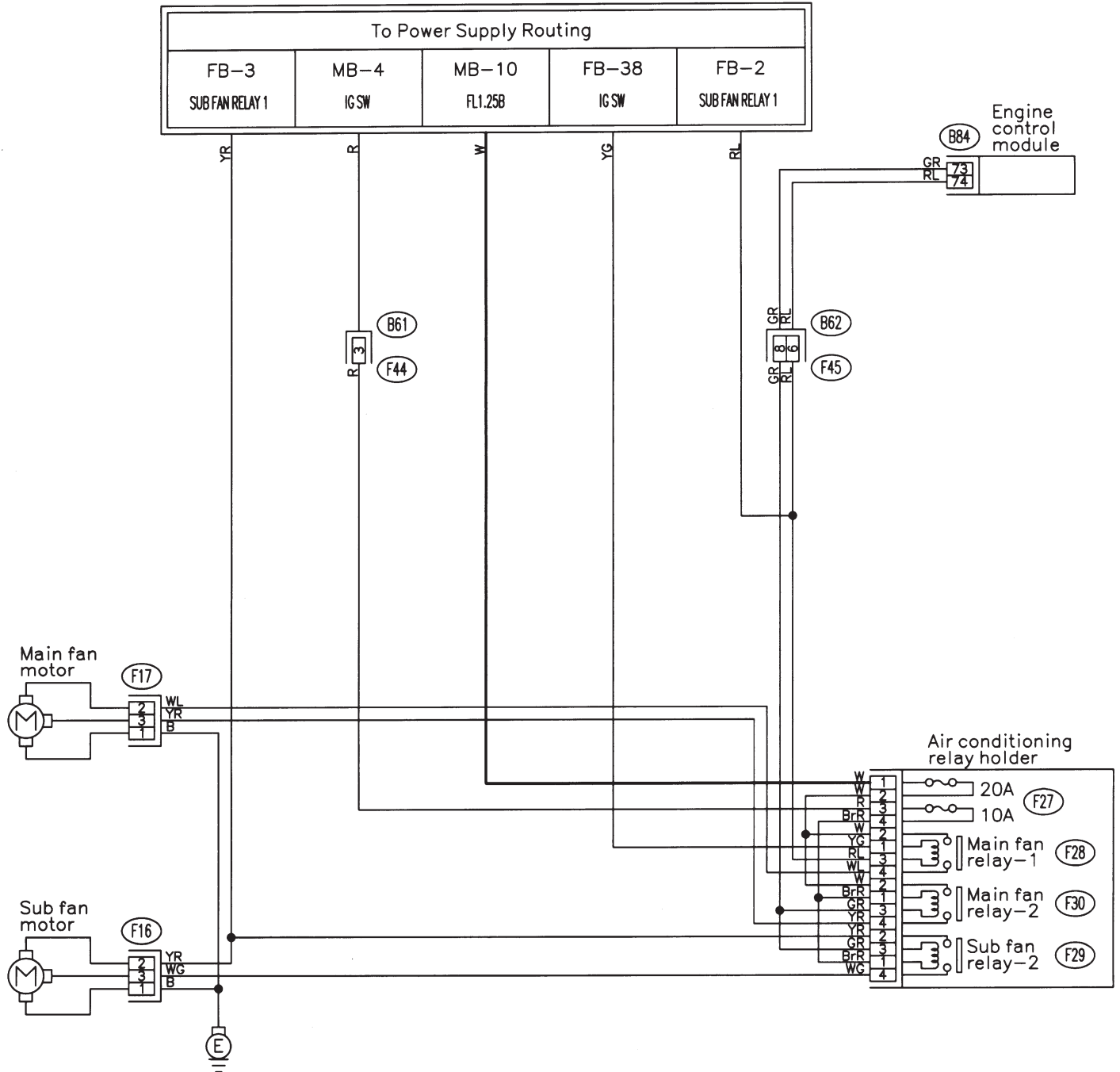

(F16) (Black)
(F17) (Black)

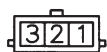

(F44)

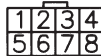

(F45)



(F27) (F28) (F29) (F30) (F31)

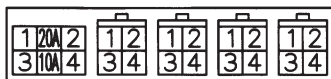

A/C relay holder (Black)

(B84) (Light blue)

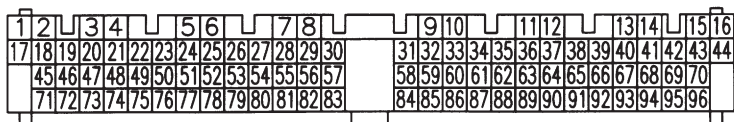

AA: REAR WINDOW DEFOGGER SYSTEM

1. LHD MODEL

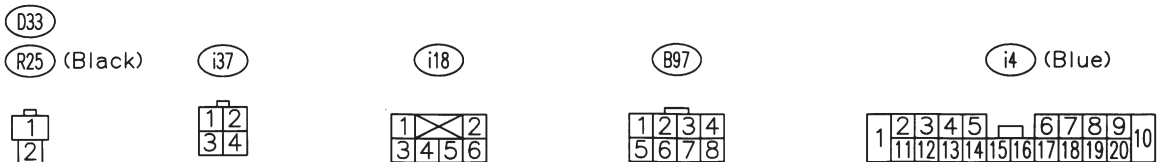
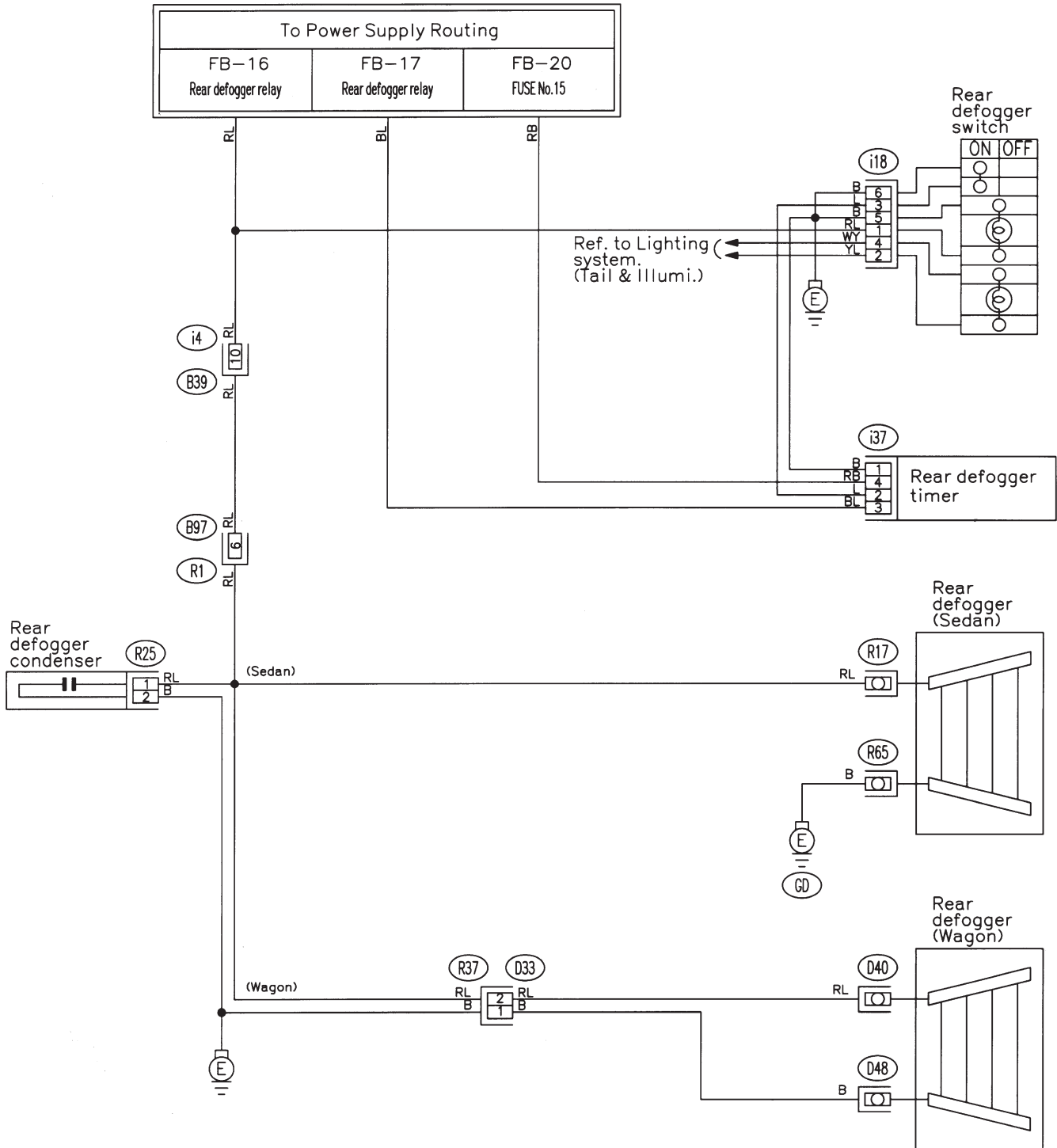

2. RHD MODEL

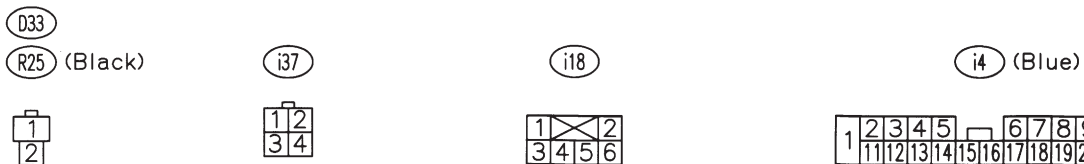
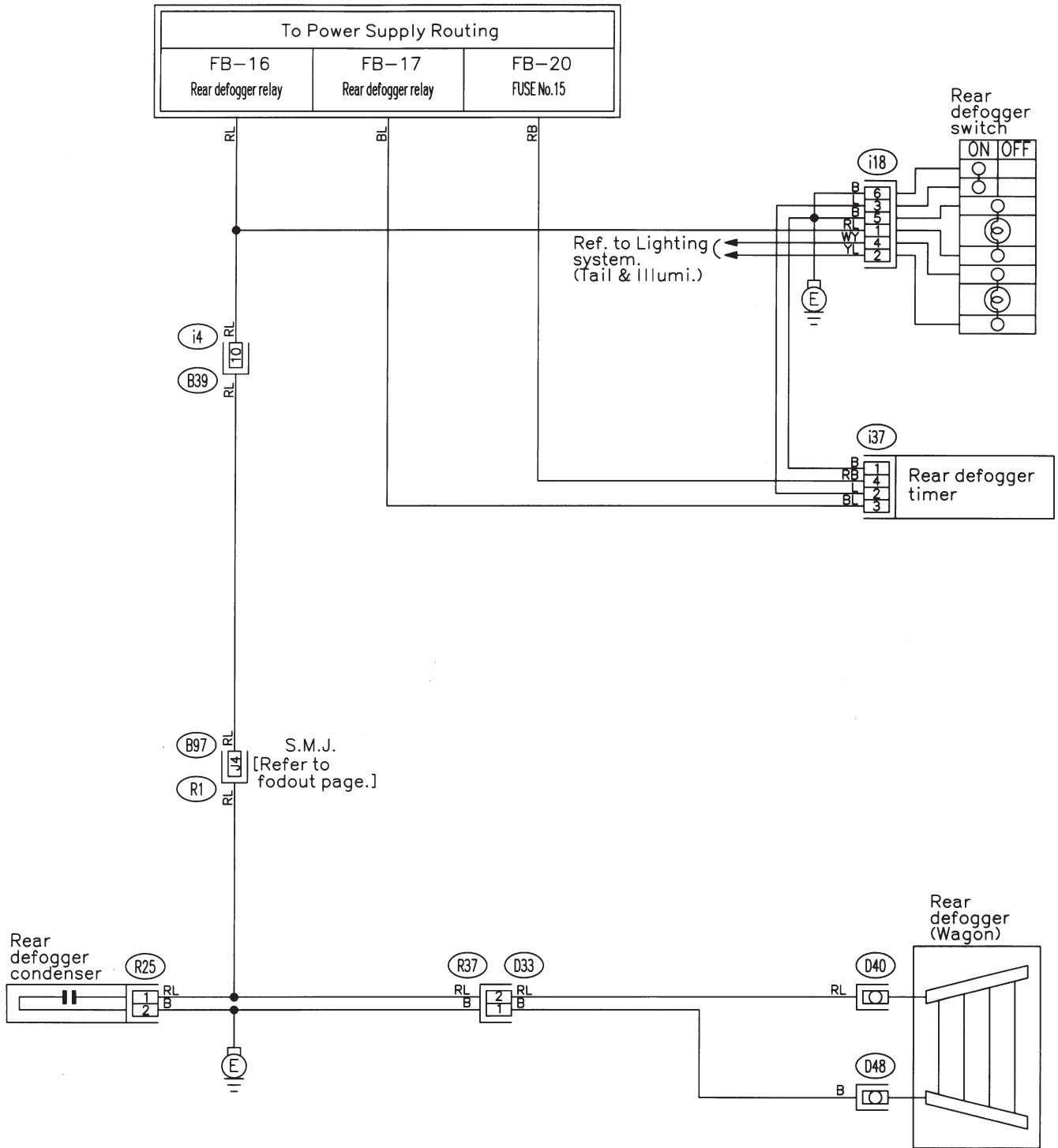

2. RHD MODEL

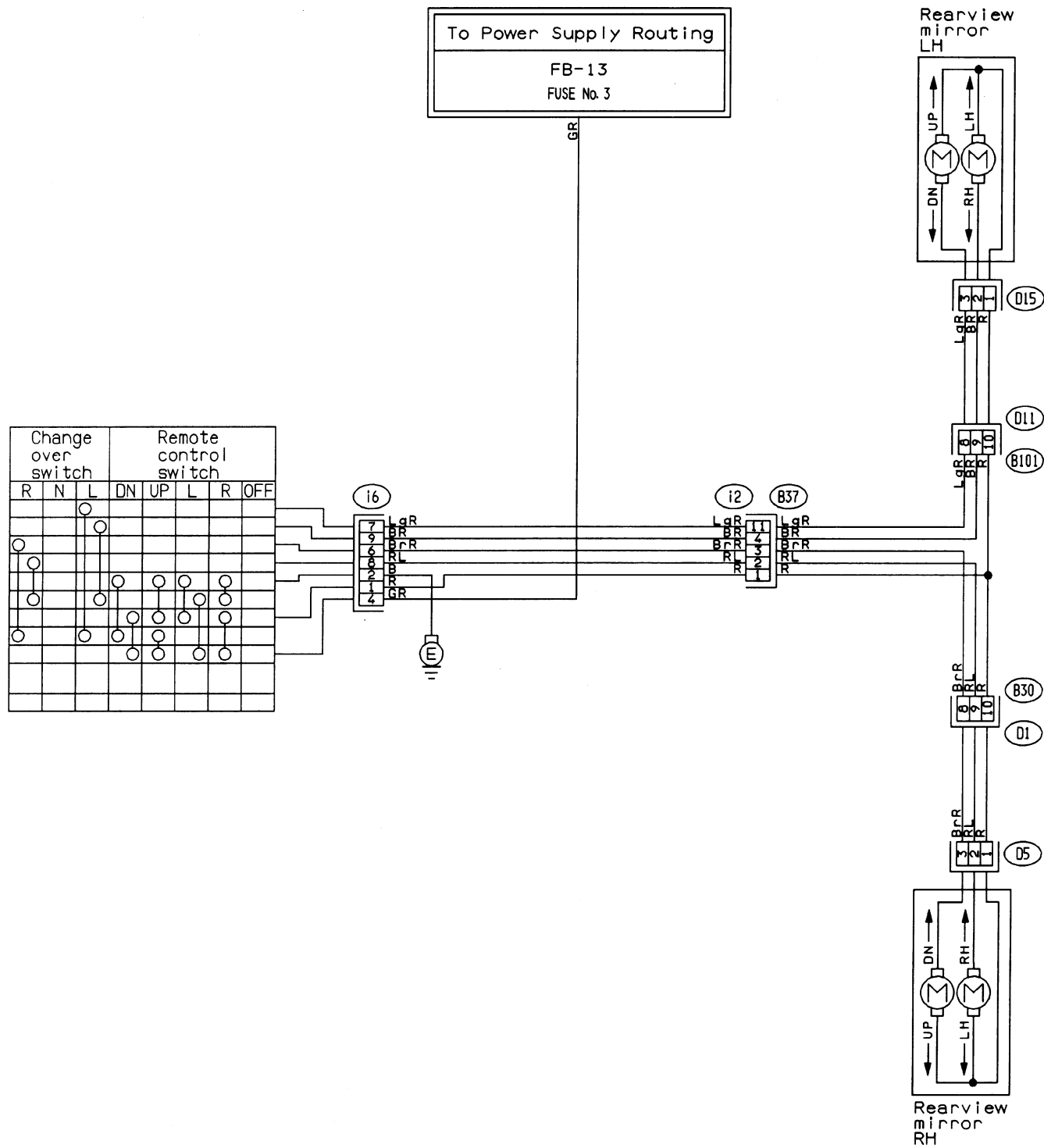

(D5) (D15)

(i6)

(i2)

(B30) (B101)

1	2	3
4	5	6

1	2	3	4	5
6	7	8	9	10

1	2	3	4	5	6	7	8	9	10		
11	12	13	14	15	16	17	18	19	20	21	22

1	2	3	X	4	5	6	
7	8	9	10	11	12	13	14
15	16	17	18	19	20		
21	22	23	24				

AC: SEAT BELT WARNING AND KEY WARNING SYSTEM

1. LHD MODEL

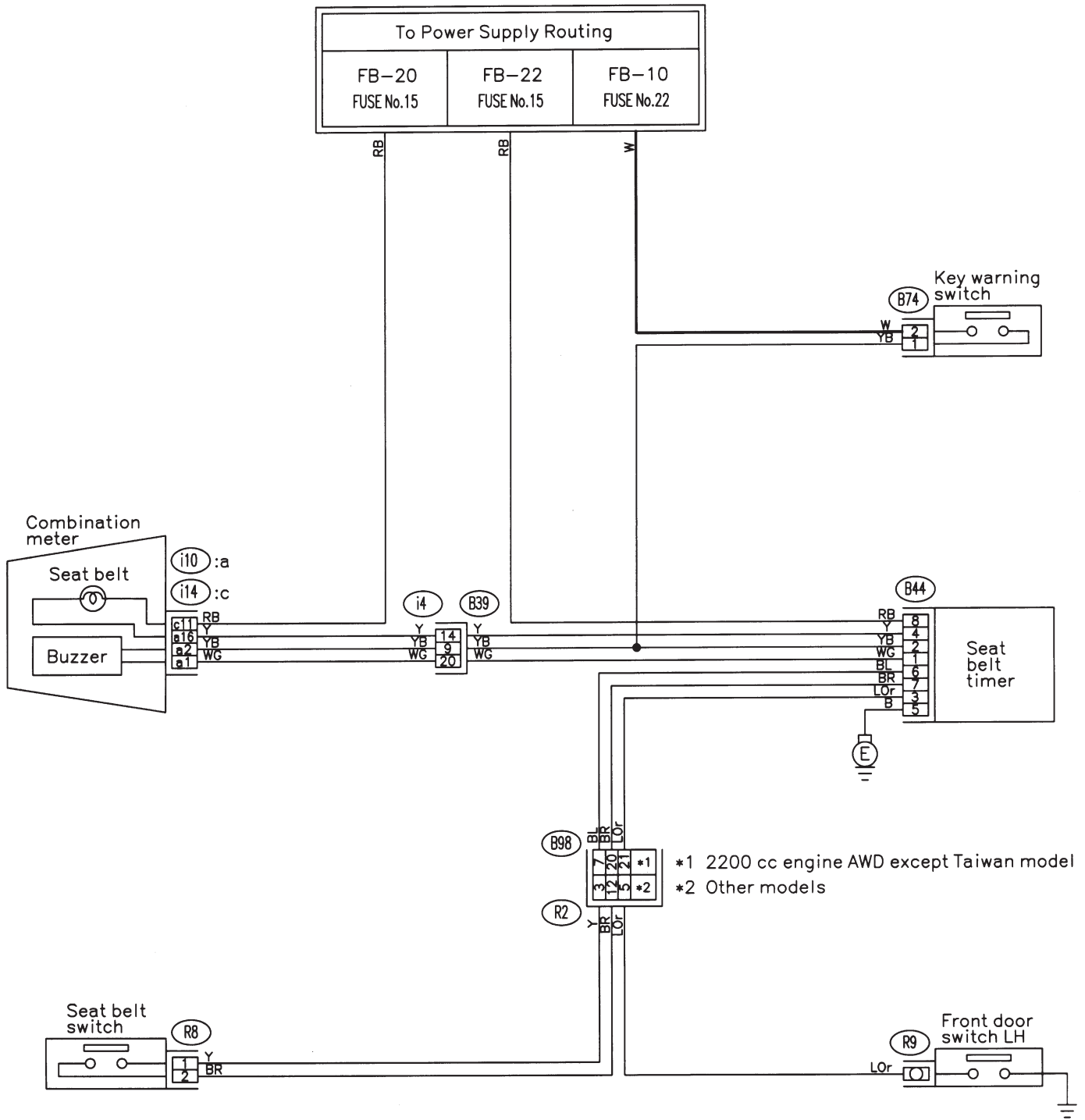

(R8) (B74) (Black)



(B44)

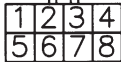

(i4) (Blue)



(i14)



(i10) (Light gray)

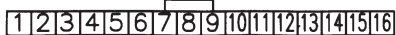

(*1 • Black)



(B98)

(*2)

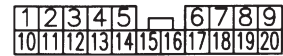

2. RHD MODEL

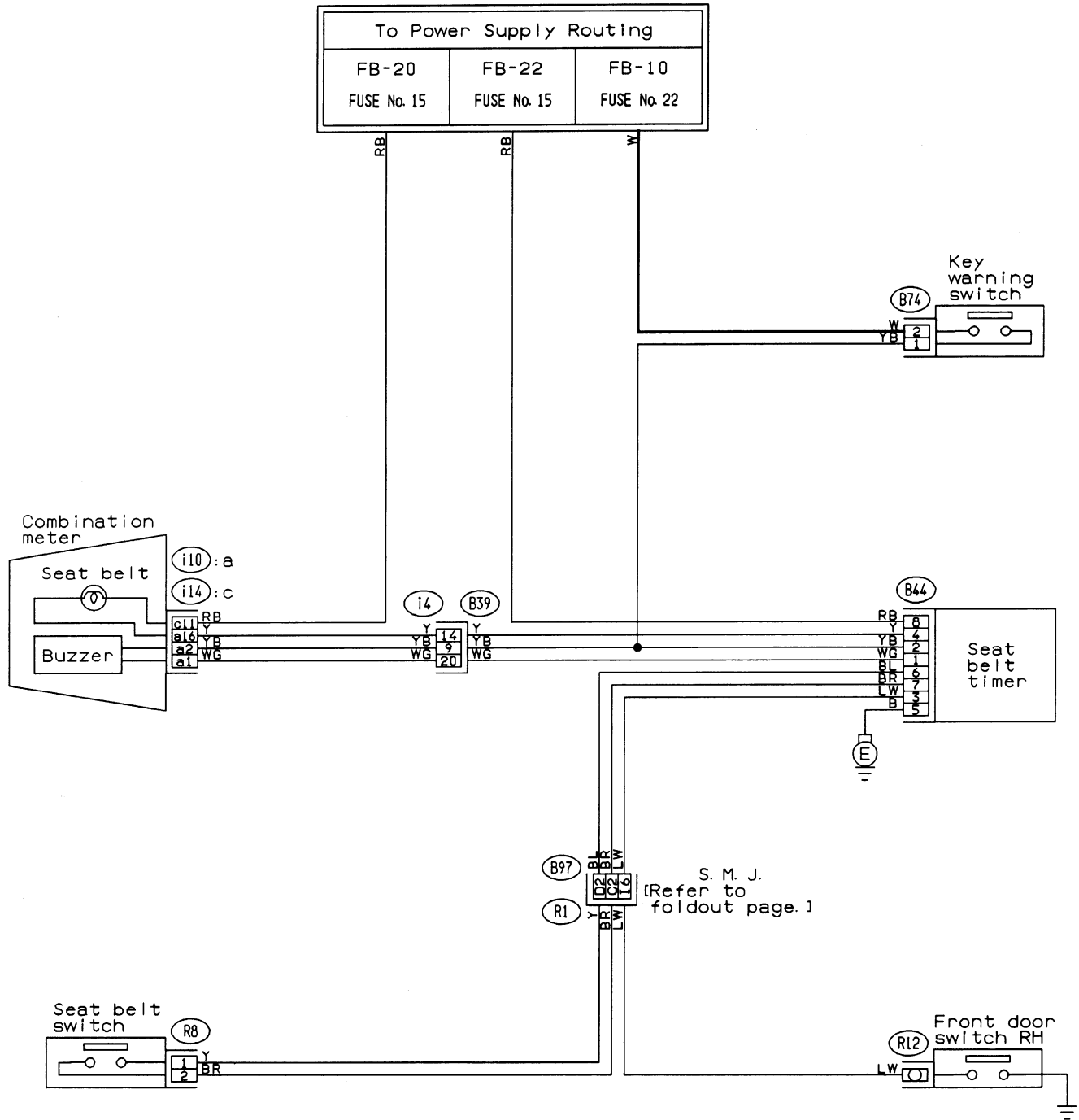

(R8) (B74) (Black)



(B44)

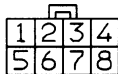

(i14)

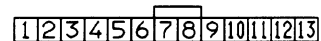

(i10) (Light gray)

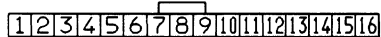

(i4) (Blue)

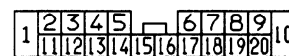

AD: SEAT HEATER SYSTEM

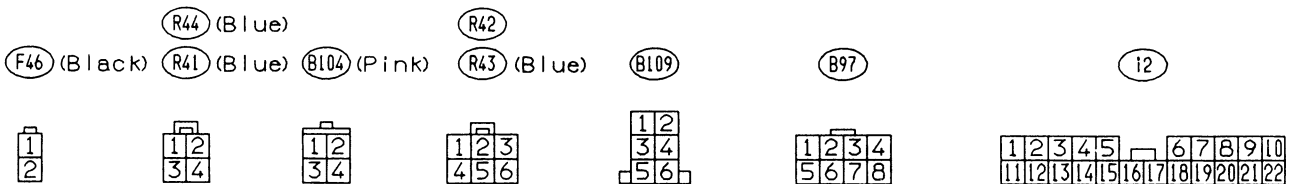
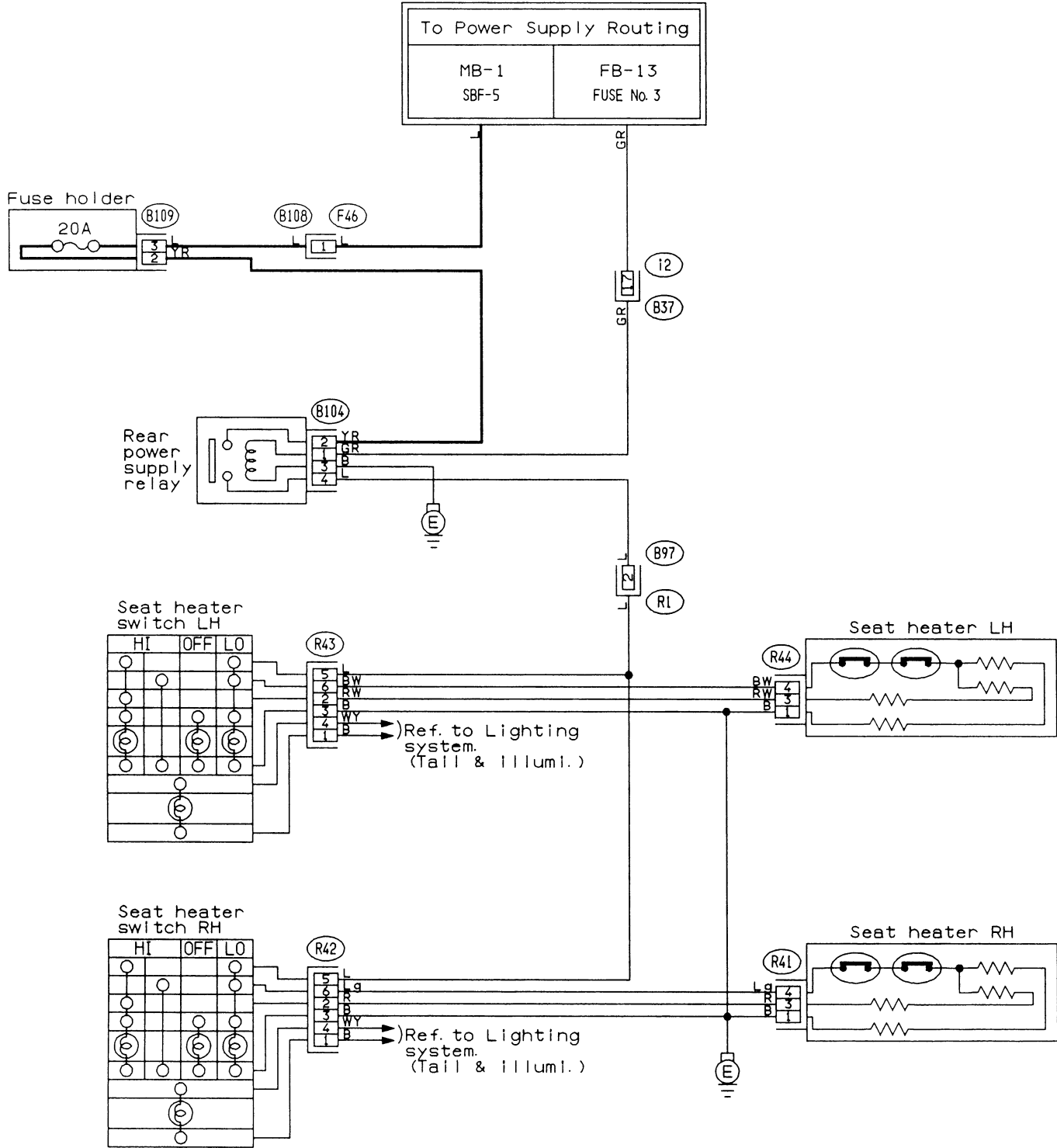

MEMO:

AE: SECURITY SYSTEM

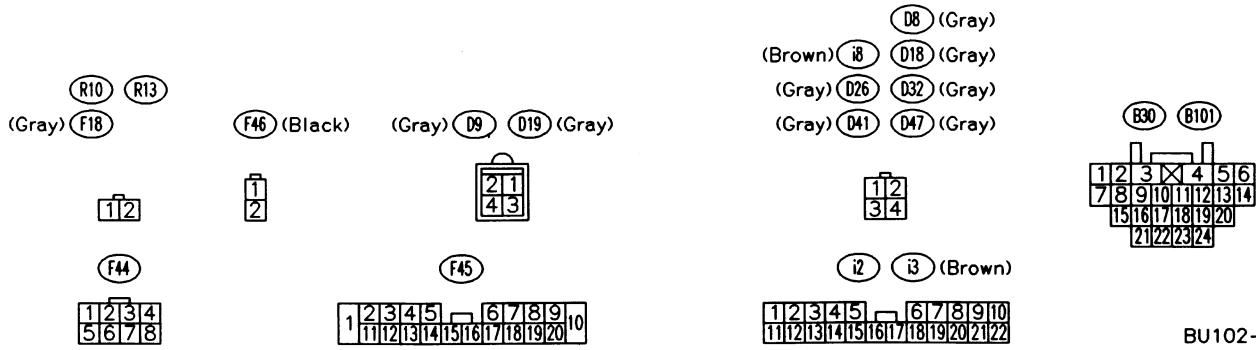
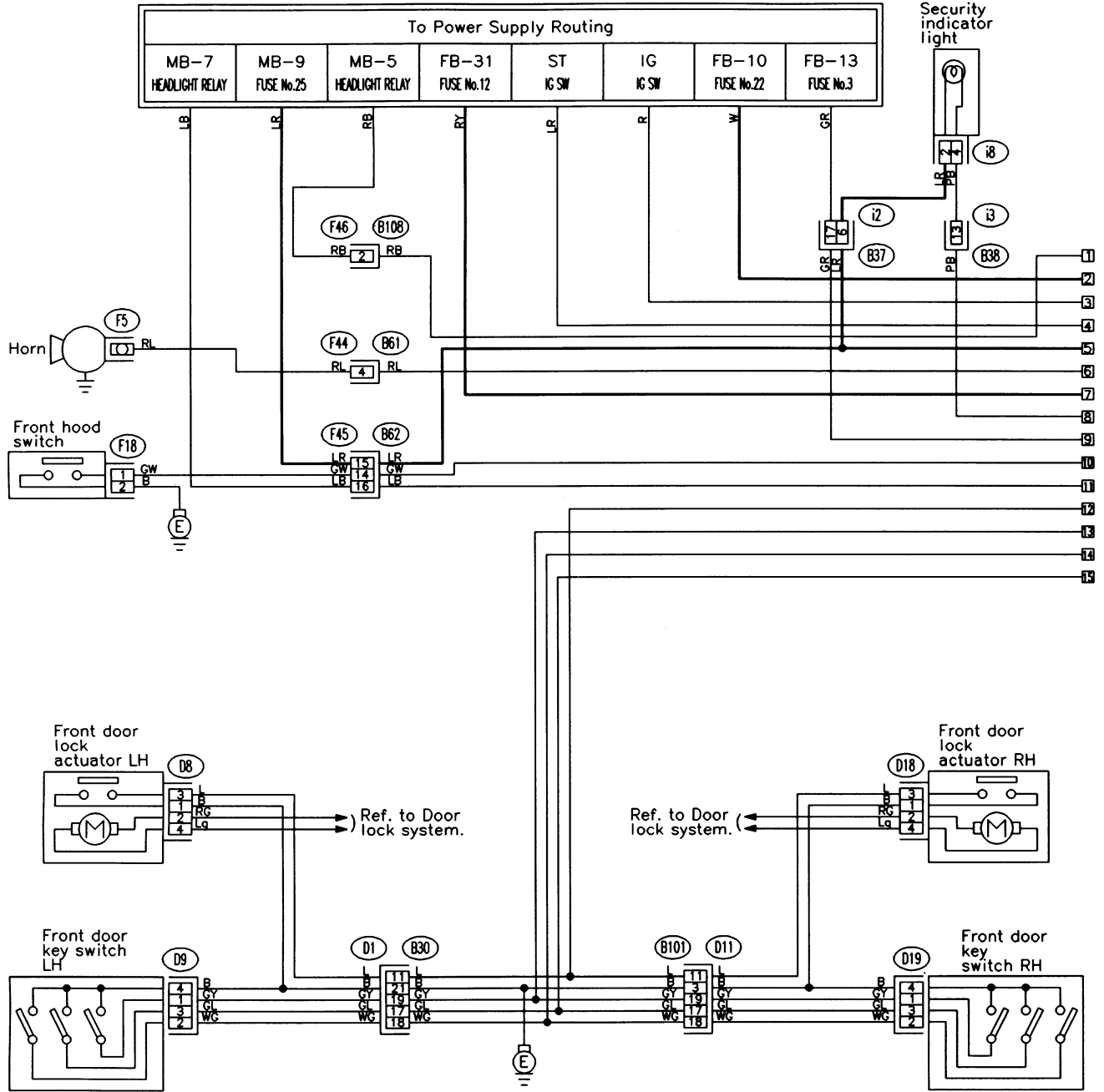

BU102-03A

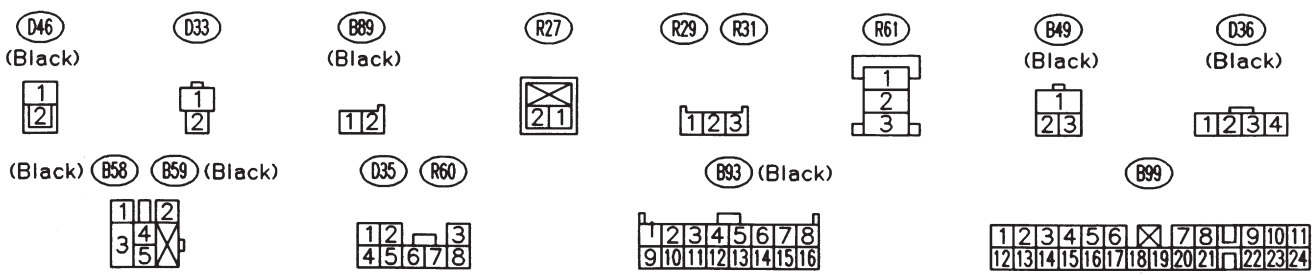
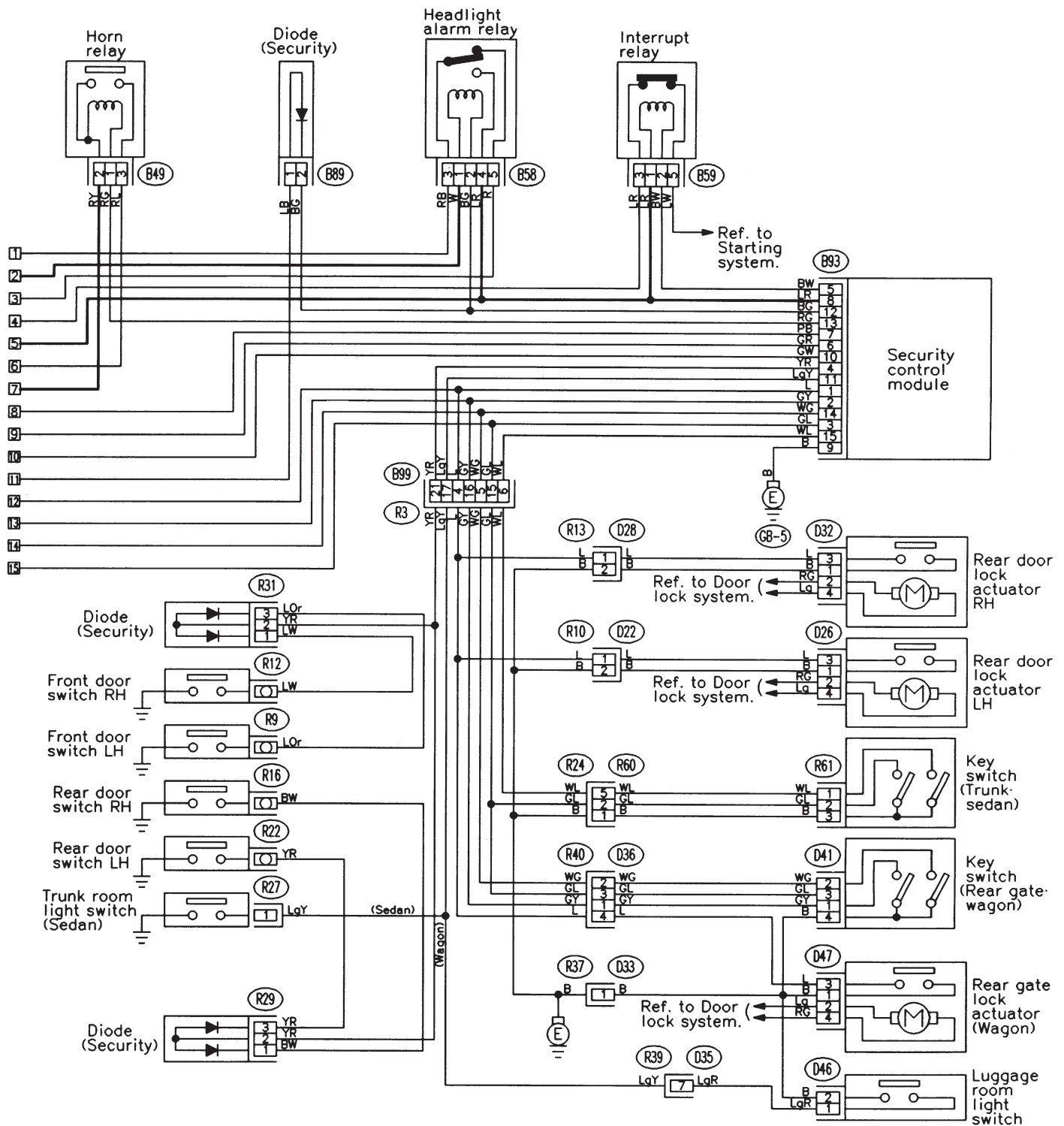

AG: SUNROOF SYSTEM

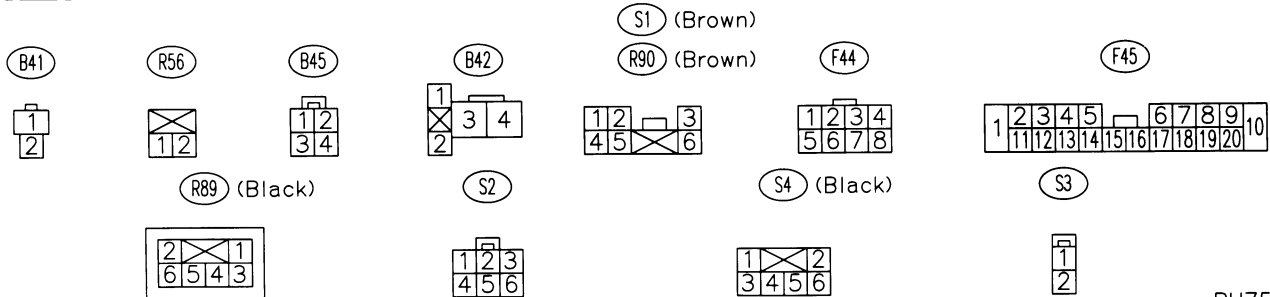
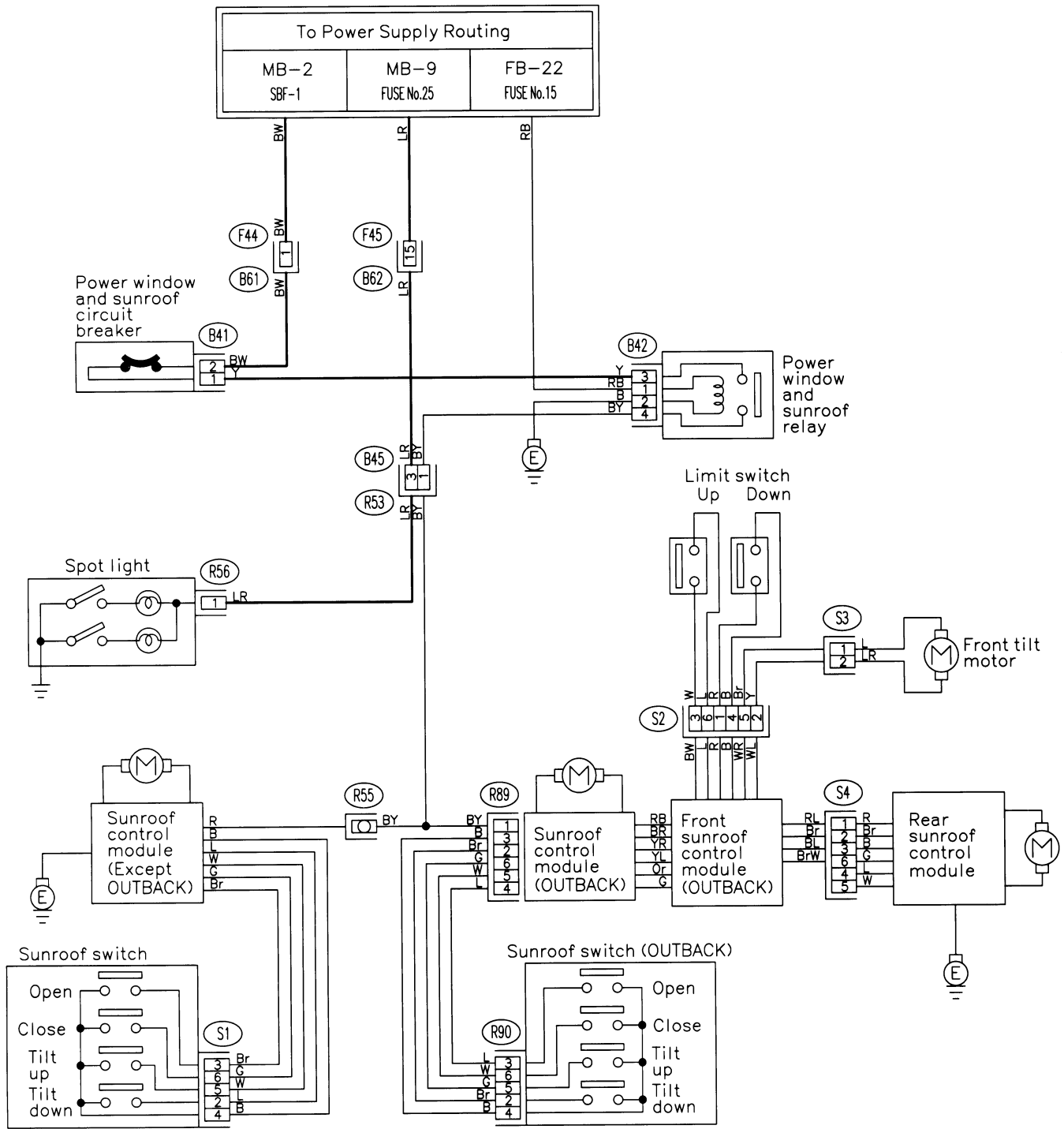

AH: WIPER AND WASHER SYSTEM (FRONT)

1. LHD MODEL

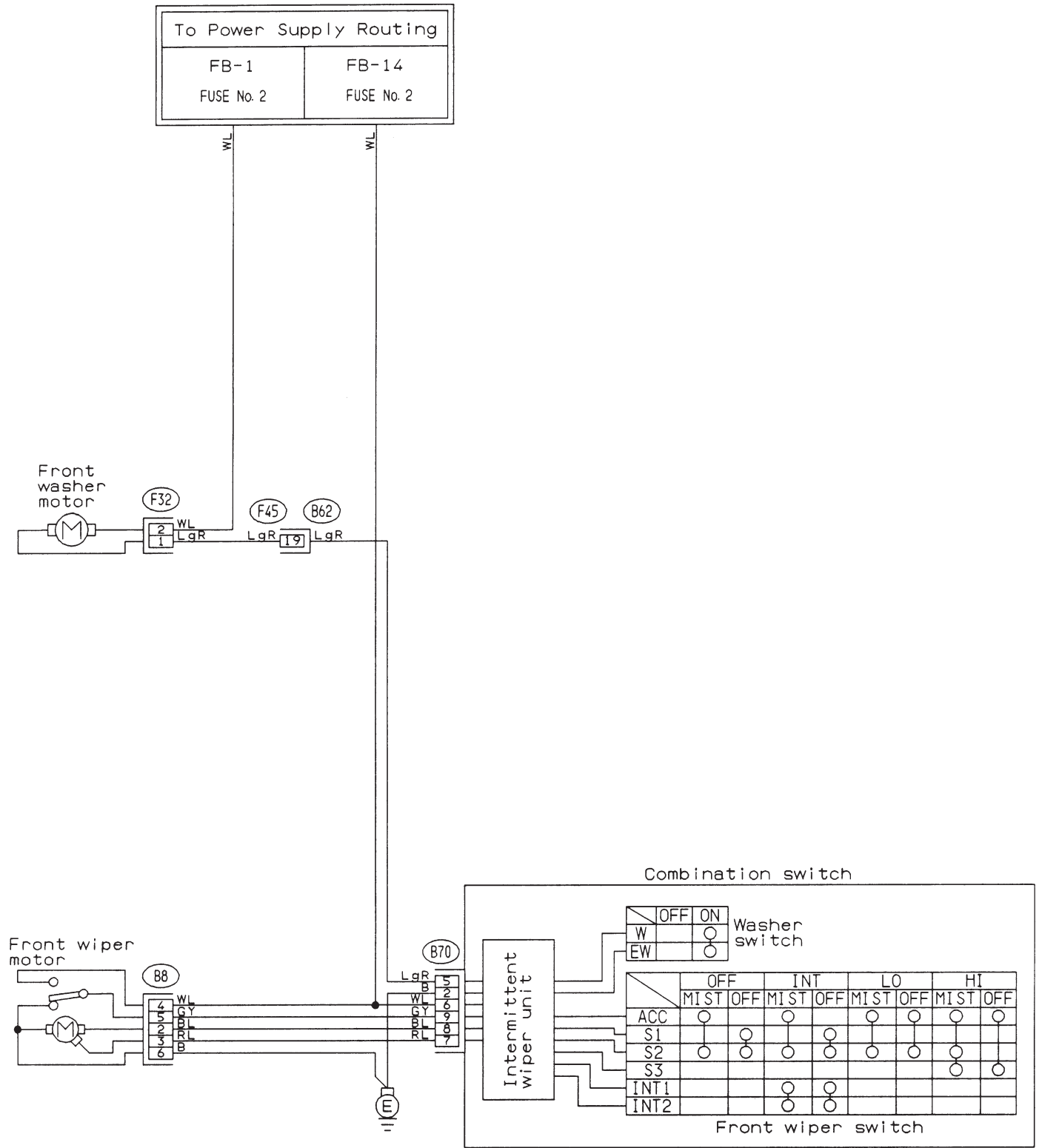

F32 (Green)



B8



B70

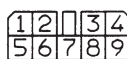

F45

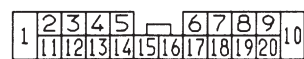

2. RHD MODEL

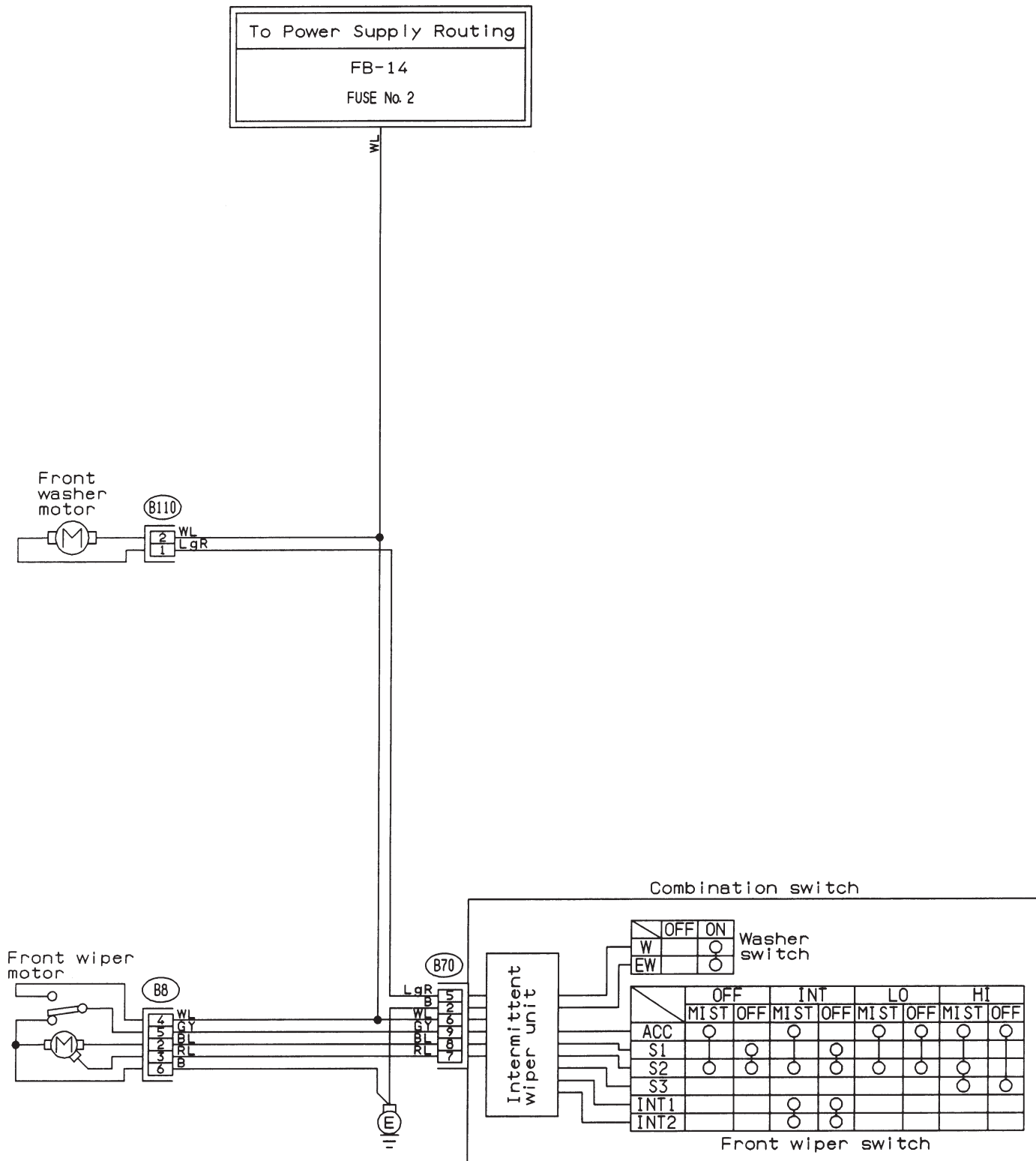

(B110) (Green)



(B8)



(B70)

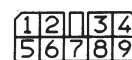

BUR50-01

AI: WIPER AND WASHER SYSTEM (REAR)

1. LHD MODEL

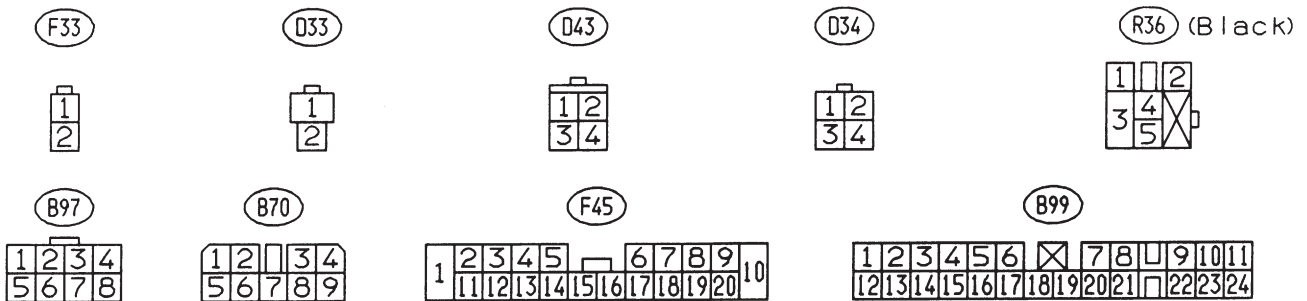
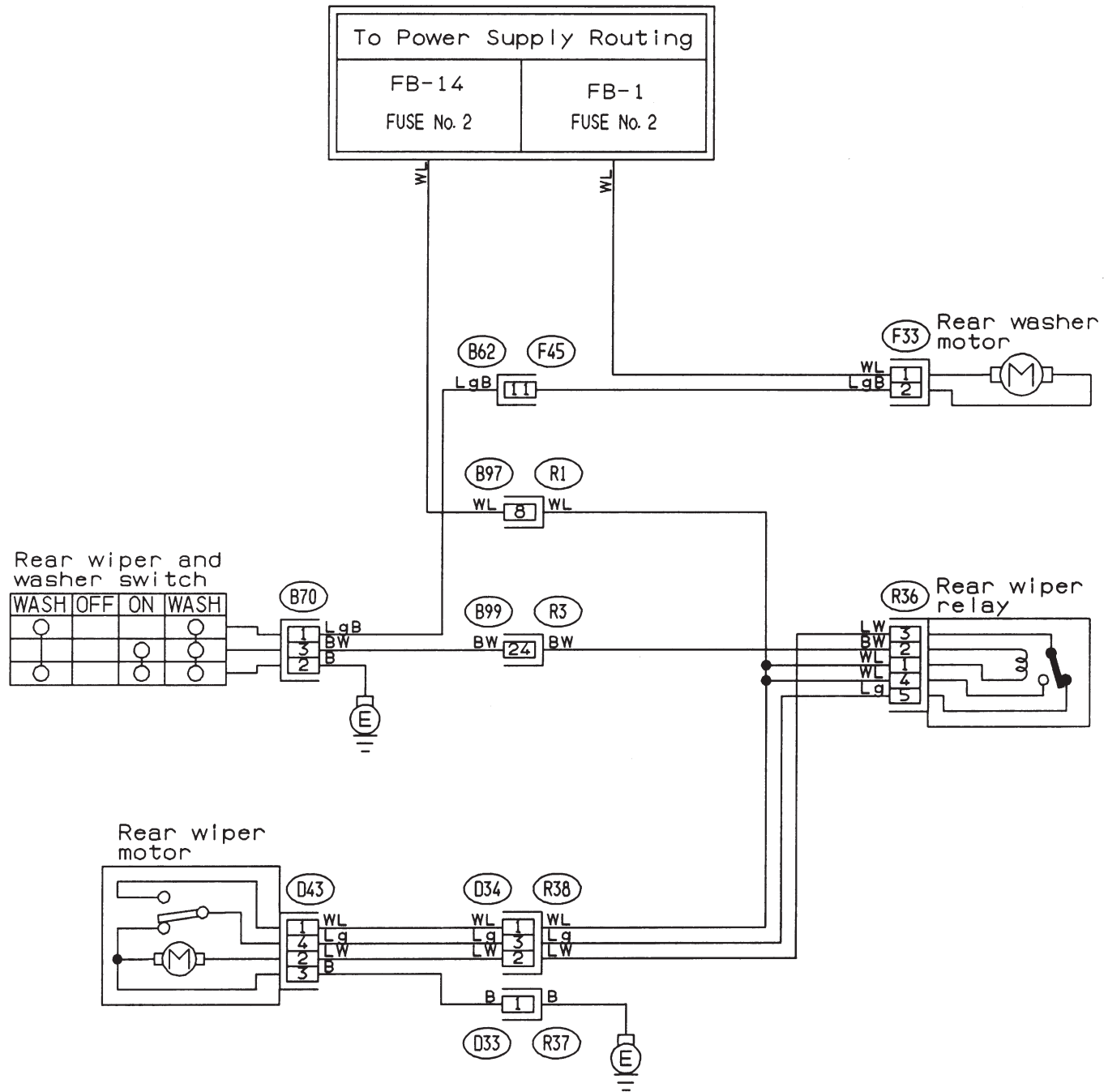

2. RHD MODEL

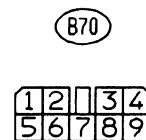
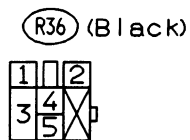
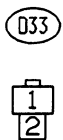
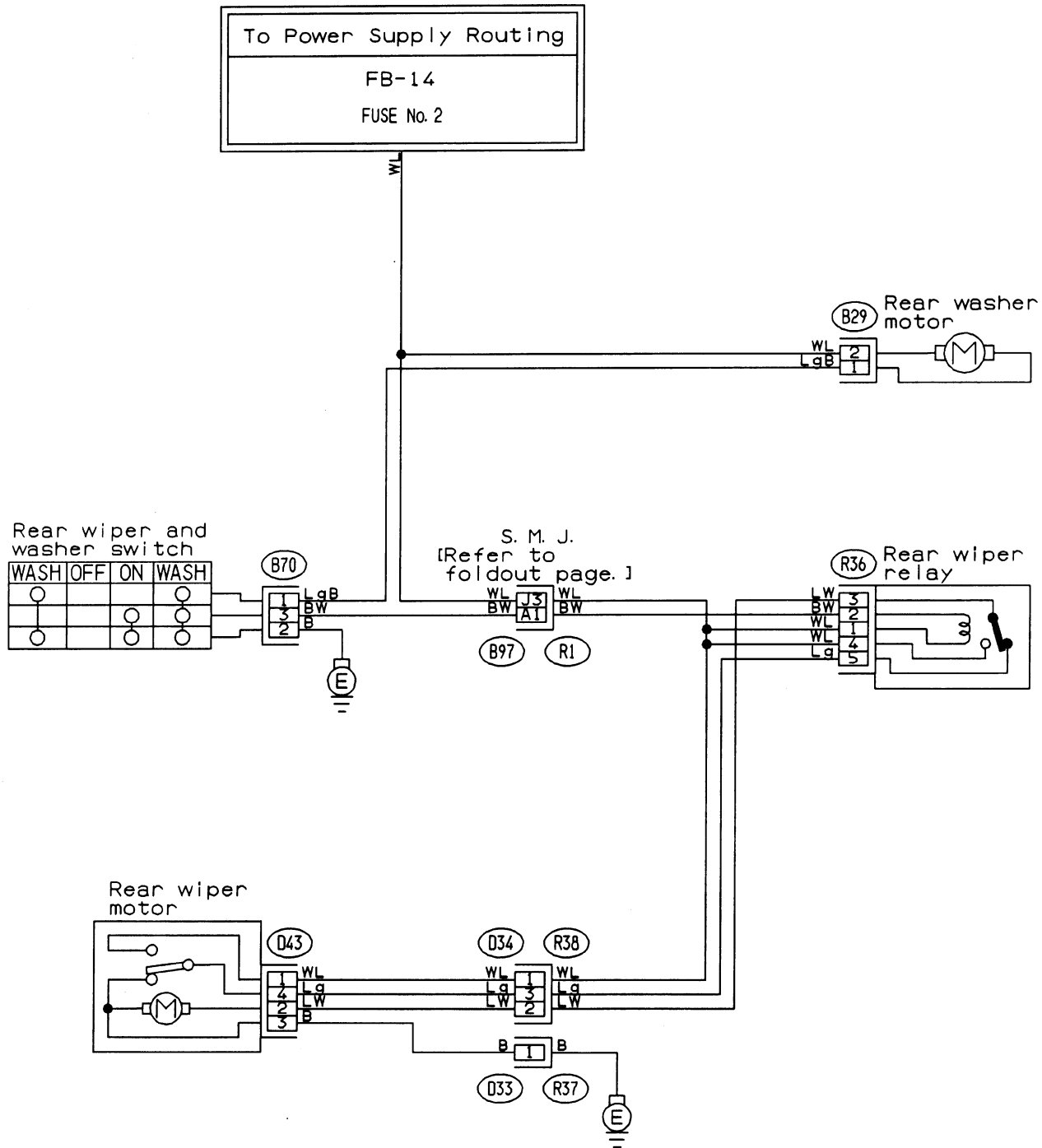

AJ: WIPER DEICER SYSTEM

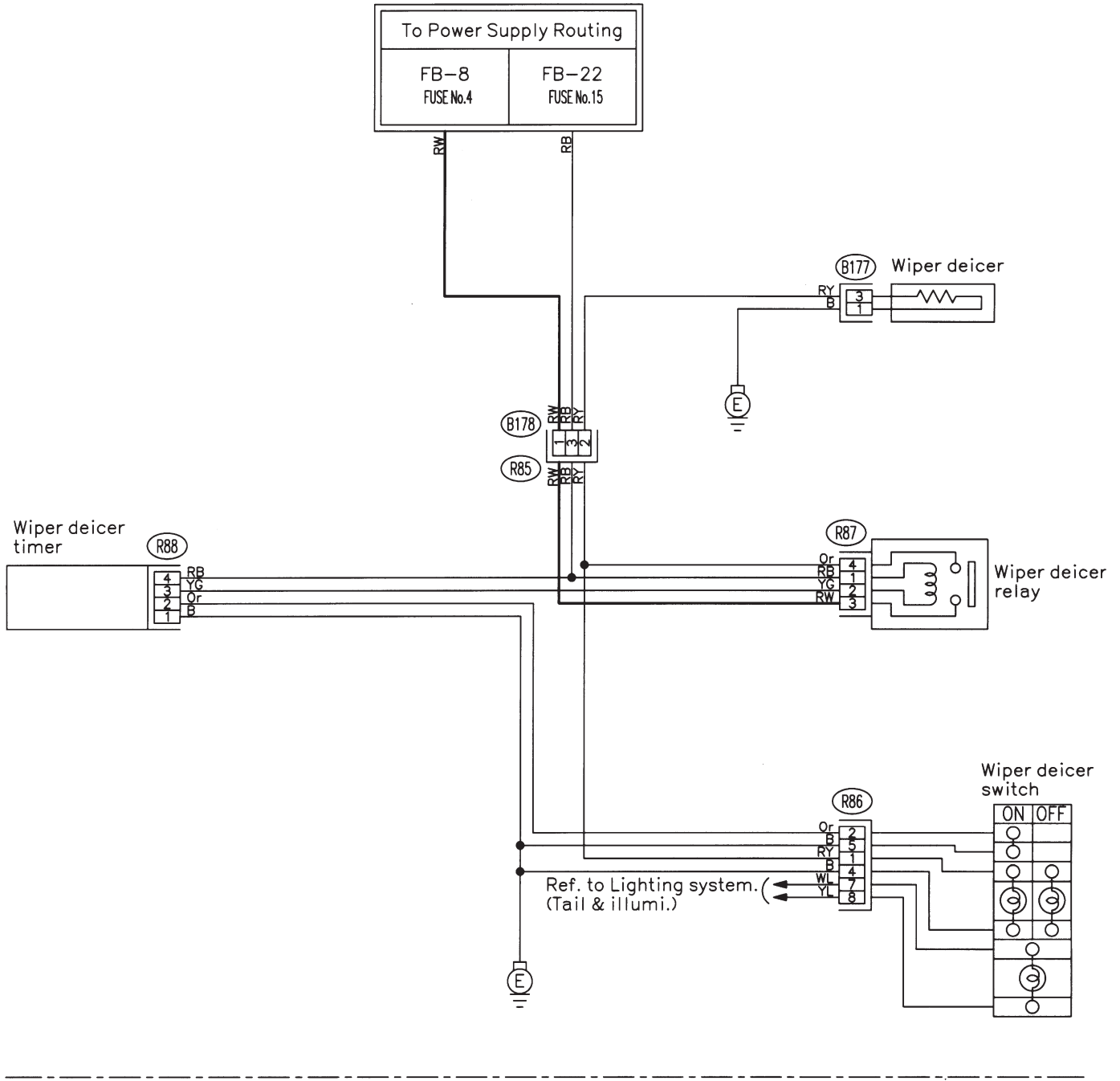

(B178)



(B177) (Gray)

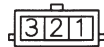

(R88)



(R87) (Blue)



(R86)

