

**SUPPLEMENT FOR 6 CYLINDER  
ENGINE MODEL**

This service manual has been prepared to provide SUBARU service personnel with the necessary information and data for the correct maintenance and repair of SUBARU vehicles.

This manual includes the procedures for maintenance, disassembling, reassembling, inspection and adjustment of components and diagnostics for guidance of experienced mechanics.

Please peruse and utilize this manual fully to ensure complete repair work for satisfying our customers by keeping their vehicle in optimum condition. When replacement of parts during repair work is needed, be sure to use SUBARU genuine parts.

All information, illustration and specifications contained in this manual are based on the latest product information available at the time of publication approval.

**FOREWORD****FW****HOW TO USE THIS MANUAL****HU****SPECIFICATIONS****SPC****PRECAUTION****PC****NOTE****NT****IDENTIFICATION****ID****RECOMMENDED MATERIALS****RM****PRE-DELIVERY INSPECTION****PI****PERIODICAL MAINTENANCE****PM**

**SUPPLEMENT FOR 6 CYLINDER  
ENGINE MODEL****FUEL INJECTION (FUEL SYSTEMS) FU(H6)****EMISSION CONTROL  
(AUX. EMISSION CONTROL DEVICES) EC(H6)****INTAKE (INDUCTION) IN(H6)****MECHANICAL ME(H6)****EXHAUST EX(H6)****COOLING CO(H6)****LUBRICATION LU(H6)****SPEED CONTROL SYSTEMS SP(H6)****IGNITION IG(H6)****START/CHARGING SYSTEMS SC(H6)****ENGINE (DIAGNOSTICS) EN(H6)****REAR SUSPENSION RS****WIRING SYSTEM WI**

# INTAKE (INDUCTION)

# *IN(H6)*

---

	Page
1. General Description.....	2
2. Air Cleaner .....	5
3. Air Intake Chamber .....	6
4. Air Intake Duct.....	7
5. Resonator Chamber.....	8

# GENERAL DESCRIPTION

Intake (Induction)

## 1. General Description S144001

### A: COMPONENT S144001A05

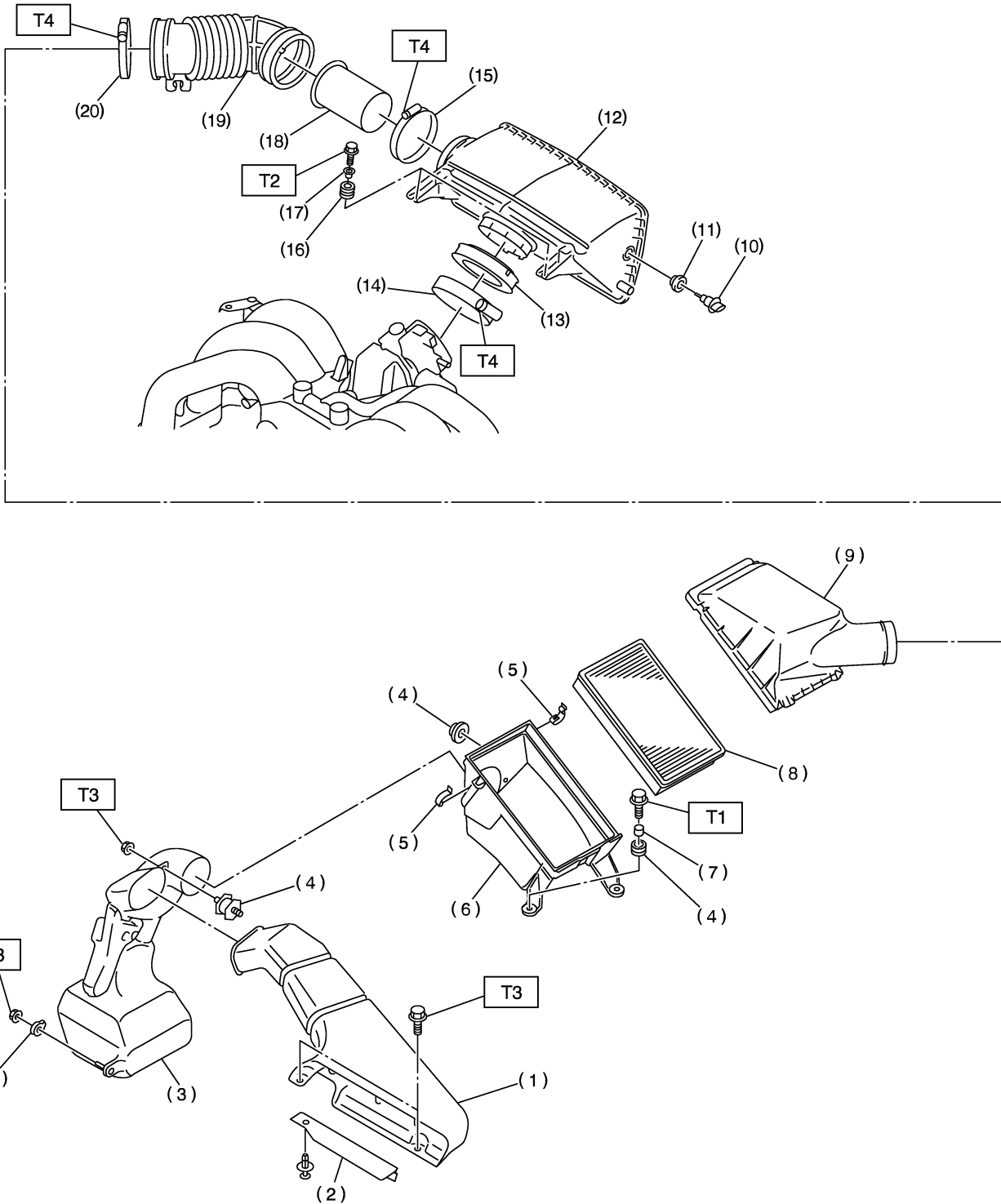

B2M4400A

# GENERAL DESCRIPTION

Intake (Induction)

- (1) Air intake duct
- (2) Plate
- (3) Resonator chamber
- (4) Cushion
- (5) Clip
- (6) Air cleaner lower case
- (7) Spacer
- (8) Air cleaner element
- (9) Air cleaner upper cover

- (10) Intake air temperature sensor
- (11) Grommet
- (12) Air intake chamber
- (13) Grommet
- (14) Clamp
- (15) Clamp
- (16) Cushion
- (17) Spacer
- (18) Intake duct

- (19) Air intake boot
- (20) Clamp

---

***Tightening torque: N·m (kgf·m, ft·lb)***

***T1: 32.3 (3.3, 23.9)***

***T2: 6.4 (0.65 4.7)***

***T3: 7.5 (0.76, 5.5)***

***T4: 3 (0.3, 2.2)***

---

## GENERAL DESCRIPTION

Intake (Induction)

---

### **B: CAUTION** S144001A03

- Wear working clothing, including a cap, protective goggles, and protective shoes during operation.
- Remove contamination including dirt and corrosion before removal, installation or disassembly.
- Keep the disassembled parts in order and protect them from dust or dirt.
- Before removal, installation or disassembly, be sure to clarify the failure. Avoid unnecessary removal, installation, disassembly, and replacement.
- Be careful not to burn your hands, because each part on the vehicle is hot after running.
- Be sure to tighten fasteners including bolts and nuts to the specified torque.
- Place shop jacks or safety stands at the specified points.
- Before disconnecting electrical connectors of sensor or units, be sure to disconnect negative terminal from battery.

## 2. Air Cleaner S144087

### A: REMOVAL S144087A18

- 1) Loosen clamp (A), and separate air cleaner upper cover and air intake chamber.
- 2) Remove the clip (B) above the air cleaner upper cover.

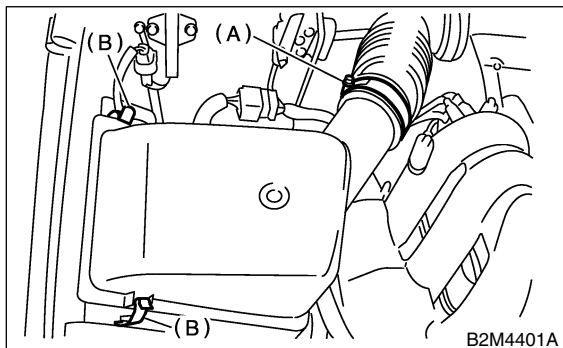

- 3) Remove air cleaner element.
- 4) Remove air cleaner lower case.

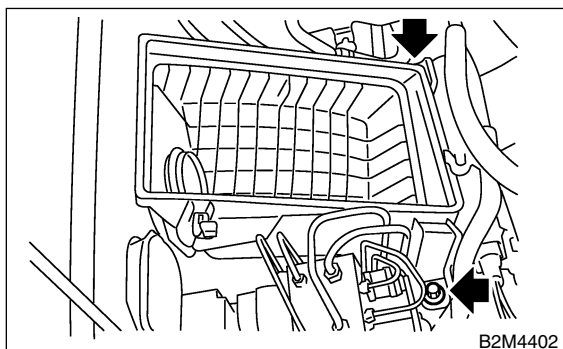

### B: INSTALLATION S144087A11

- 1) Install the air cleaner lower case.

#### **Tightening torque:**

**32.3 N·m (3.3 kgf·m, 23.9 ft·lb)**

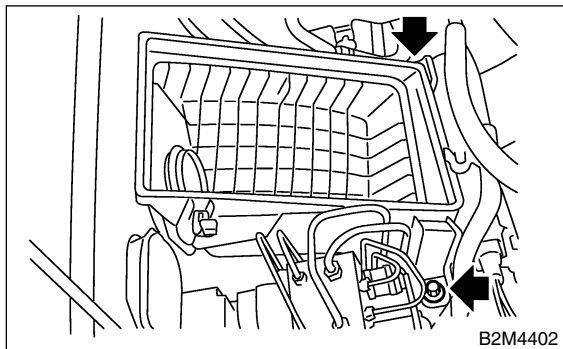

- 2) Set the air cleaner element.
- 3) Install the air cleaner upper cover.

#### NOTE:

Before installing air cleaner upper cover, align holes with protruding portions of air cleaner lower case, then secure upper cover to lower case.

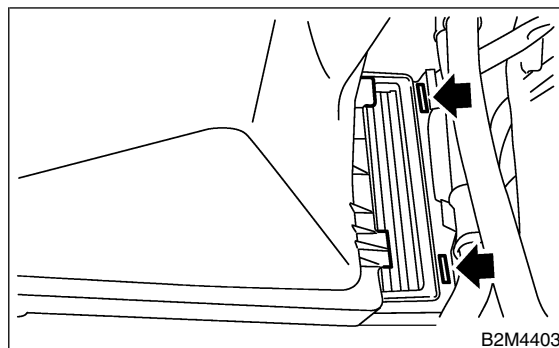

- 4) Install the clip (B) above the air cleaner upper cover.
- 5) Tighten clamp (A), and connect air intake boot and air cleaner upper cover.

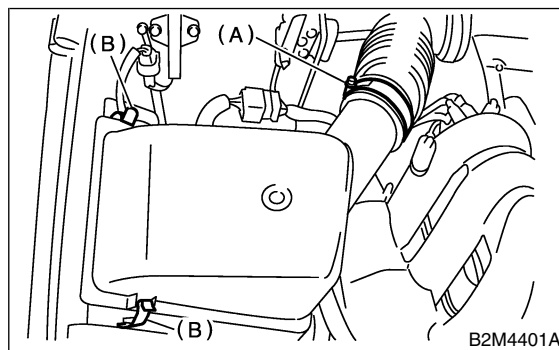

### C: INSPECTION S144087A10

Replace if excessively damaged or dirty.

# AIR INTAKE CHAMBER

Intake (Induction)

## 3. Air Intake Chamber S144757

### A: REMOVAL S144757A18

- 1) Disconnect battery ground cable.

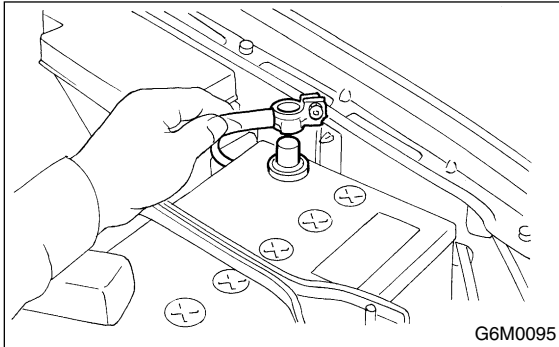

- 2) Disconnect connector from intake air temperature sensor.

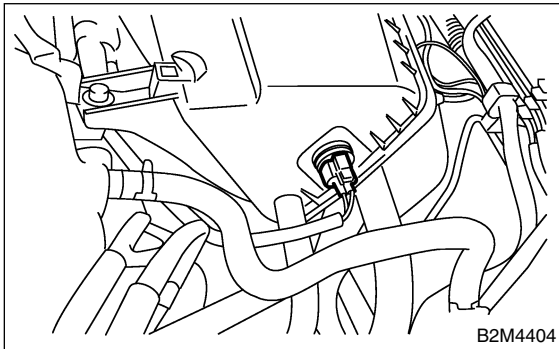

- 3) Loosen clamp (A) which connects air intake chamber to throttle body.
- 4) Remove bolts (B) which install air intake chamber to intake manifold.
- 5) Loosen clamp (C) which connects air intake chamber to air intake boot.

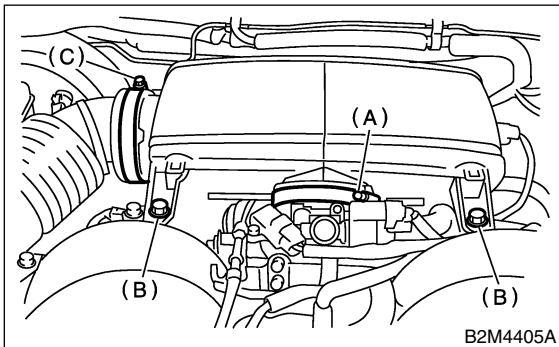

- 6) Disconnect hoses from air intake chamber.
- 7) Remove air intake chamber.

### B: INSTALLATION S144757A11

Install in the reverse order of removal.

### C: INSPECTION S144757A10

Inspect for cracks and loose connections.



## 4. Air Intake Duct S144566

### A: REMOVAL S144566A18

1) Remove bolts which install air intake duct on the front side of body.

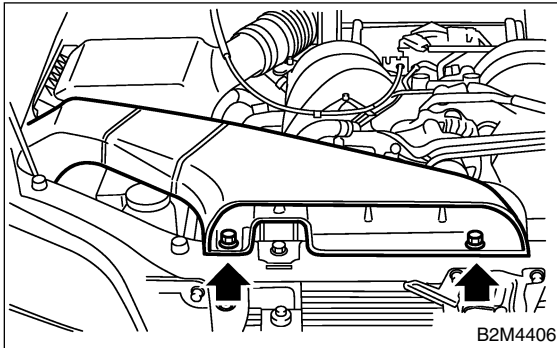

### B: INSTALLATION S144566A11

Install in the reverse order of removal.

### C: INSPECTION S144566A10

Inspect for cracks and loose connections. Check that no foreign objects are mixed in the air intake duct.

# RESONATOR CHAMBER

Intake (Induction)

## 5. Resonator Chamber S144639

### A: REMOVAL S144639A18

- 1) Set vehicle on a lift.
- 2) Remove air intake duct. <Ref. to IN(H6)-7, REMOVAL, Air Intake Duct.>
- 3) Remove air cleaner lower case. <Ref. to IN(H6)-5, REMOVAL, Air Cleaner.>
- 4) Remove the resonator chamber mounting bolt on the right of engine compartment.

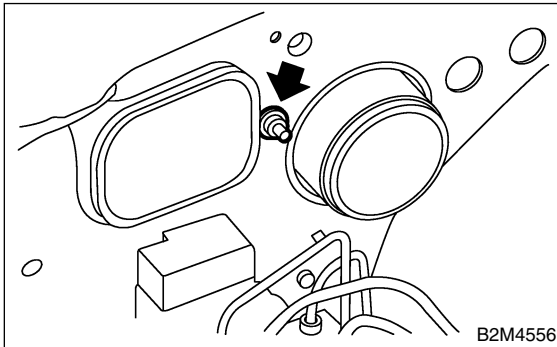

- 5) Remove the front right tire, and lift the vehicle.
- 6) Remove front mudguard RH.
- 7) Remove the resonator chamber (A) from the inside front fender.

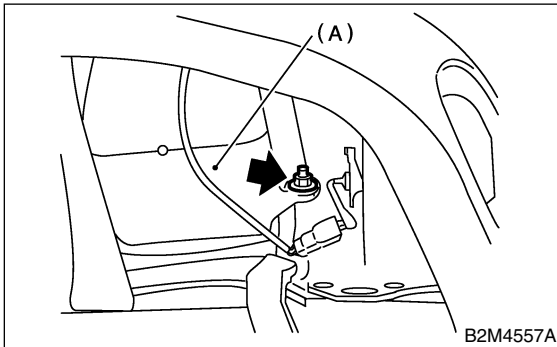

### B: INSTALLATION S144639A11

Install in the reverse order of removal.

### C: INSPECTION S144639A10

Inspect for cracks and loose connections. Check that no foreign objects and mixed in the resonator chamber.