

**SUPPLEMENT FOR 6 CYLINDER
ENGINE MODEL**

This service manual has been prepared to provide SUBARU service personnel with the necessary information and data for the correct maintenance and repair of SUBARU vehicles.

This manual includes the procedures for maintenance, disassembling, reassembling, inspection and adjustment of components and diagnostics for guidance of experienced mechanics.

Please peruse and utilize this manual fully to ensure complete repair work for satisfying our customers by keeping their vehicle in optimum condition. When replacement of parts during repair work is needed, be sure to use SUBARU genuine parts.

All information, illustration and specifications contained in this manual are based on the latest product information available at the time of publication approval.

FOREWORD**FW****HOW TO USE THIS MANUAL****HU****SPECIFICATIONS****SPC****PRECAUTION****PC****NOTE****NT****IDENTIFICATION****ID****RECOMMENDED MATERIALS****RM****PRE-DELIVERY INSPECTION****PI****PERIODICAL MAINTENANCE****PM**

**SUPPLEMENT FOR 6 CYLINDER
ENGINE MODEL****FUEL INJECTION (FUEL SYSTEMS) FU(H6)****EMISSION CONTROL
(AUX. EMISSION CONTROL DEVICES) EC(H6)****INTAKE (INDUCTION) IN(H6)****MECHANICAL ME(H6)****EXHAUST EX(H6)****COOLING CO(H6)****LUBRICATION LU(H6)****SPEED CONTROL SYSTEMS SP(H6)****IGNITION IG(H6)****START/CHARGING SYSTEMS SC(H6)****ENGINE (DIAGNOSTICS) EN(H6)****REAR SUSPENSION RS****WIRING SYSTEM WI**

WIRING SYSTEM



	Page
1. Basic Diagnostics Procedure	3
2. Working Precautions	13
3. Super Multiple Junction (SMJ)	14
4. Power Supply Routing.....	17
5. Ground Distribution	32
6. Airbag System	41
7. Air Conditioning System.....	45
8. Anti-lock Brake System.....	66
9. A/T Control System	73
10. Audio System	95
11. Charging System.....	100
12. Combination Meter.....	101
13. Cruise Control System	107
14. Door Lock System.....	120
15. Engine Coolant Temperature Gauge System	124
16. Engine Electrical System	125
17. Fuel Gauge System	181
18. Full-Time Dual-Range System	184
19. Front Accessory Power Supply System.....	185
20. Headlight Beam Leveler System.....	186
21. Horn System.....	187
22. Immobilizer System	188
23. Keyless Entry System	192
24. Back-up Light System	198
25. Clearance Light and Illumination Light System	199
26. Front Fog Light System.....	206
27. Headlight System	209
28. In Compartment Light System.....	211
29. Stop Light System	217
30. Turn Signal Light and Hazard Light System.....	219
31. Oil Pressure Warning Light System.....	223
32. Outside Temperature Display System.....	224
33. Parking Brake and Brake Fluid Level Warning System.....	225
34. Pneumatic (Air) Suspension System	226
35. Power Seat System.....	234
36. Power Window System	235
37. Radiator Fan System	244
38. Rear Accessory Power Supply System	247
39. Rear Fog Light System	248
40. Rear Window Defogger System.....	249
41. Remote Controlled Rearview Mirror System	250
42. Seat Belt Warning System	252
43. Seat Heater System.....	254
44. Starter System.....	255

GENERAL DIAGNOSTIC TABLE

45.	Sunroof System.....	256
46.	Vehicle Dynamic Control System.....	257
47.	Wiper and Washer System (Front)	273
48.	Wiper and Washer System (Rear).....	275
49.	Wiper Deicer System	277
50.	Overall Systems	278
51.	Front Wiring Harness	282
52.	Bulkhead Wiring Harness (In Engine Room).....	288
53.	Bulkhead Wiring Harness (In Compartment).....	296
54.	Engine Wiring Harness and Transmission Cord.....	305
55.	Instrument Panel Wiring Harness	309
56.	Rear Wiring Harness.....	313
57.	Door Cord.....	321
58.	Rear Wiring Harness and Trunk Lid Cord	325
59.	Rear Wiring Harness and Rear Gate Cord.....	327

1. Basic Diagnostics Procedure

S903627

A: BASIC PROCEDURES

S903267E31

1. GENERAL

S903627E3101

The most important purpose of diagnostics is to determine which part is malfunctioning quickly, to save time and labor.

2. IDENTIFICATION OF TROUBLE SYMPTOM

S903627E3102

Determine what the problem is based on the symptom.

3. PROBABLE CAUSE OF TROUBLE

S903627E3103

Look at the wiring diagram and check the system's circuit. Then check the switch, relay, fuse, ground, etc.

4. LOCATION AND REPAIR OF TROUBLE

S903627E3104

- 1) Using the diagnostics narrow down the causes.
- 2) If necessary, use a voltmeter, ohmmeter, etc.
- 3) Before replacing certain component parts (switch, relay, etc.), check the power supply, ground, for open wiring harness, poor connectors, etc. If no problems are encountered, check the component parts.

5. CONFIRMATION OF SYSTEM OPERATION

S903267E3105

After repairing, ensure that the system operates properly.

B: BASIC INSPECTION

S903627G51

1. VOLTAGE MEASUREMENT

S903627G5101

- 1) Using a voltmeter, connect the negative lead to a good ground point or negative battery terminal and the positive lead to the connector or component terminal.
- 2) Contact the positive probe of the voltmeter on connector (A). The voltmeter will indicate a voltage.

- 3) Shift the positive probe to connector (B). The voltmeter will indicate no voltage.

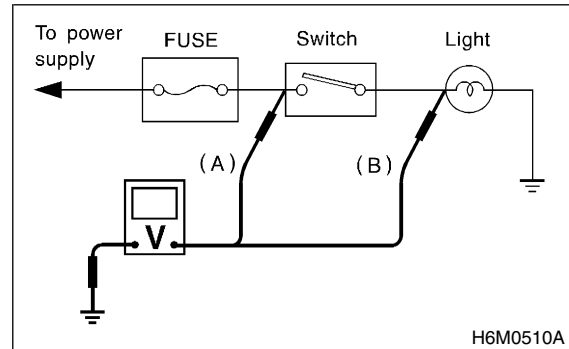

- 4) With test set-up held as it is, turn switch ON. The voltmeter will indicate a voltage and, at the same time, the light will come on.
- 5) The circuit is in good order. If a problem such as a lamp failing to light occurs, use the procedures outlined above to track down the malfunction.

2. CIRCUIT CONTINUITY CHECKS

S903627G5102

- 1) Disconnect the battery terminal or connector so there is no voltage between the check points. Contact the two leads of an ohmmeter to each of the check points. If the circuit has diodes, reverse the two leads and check again.
- 2) Use an ohmmeter to check for diode continuity. When contacting the negative lead to the diode positive side and the positive lead to the negative side, there should be continuity. When contacting the two leads in reverse, there should be no continuity.

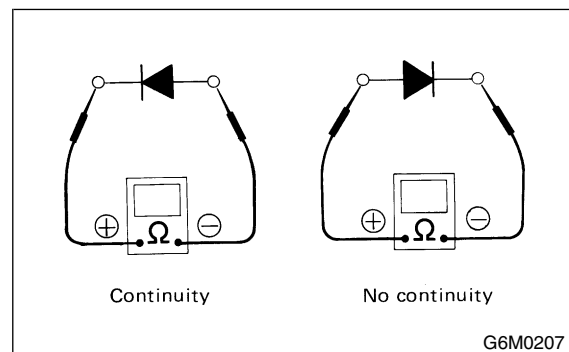

BASIC DIAGNOSTICS PROCEDURE

Wiring System

3) Symbol “○—○” indicates that continuity exists between two points or terminals. For example, when a switch position is “3”, continuity exists among terminals 1, 3 and 6, as shown in table below.

Terminal	1	2	3	4	5	6
Switch Position						
OFF						
1	○—○				○—○	
2	○—○			○—○		○—○
3	○—○		○—○			○—○
4	○—○	○—○				

B6M0749

2) Ohmmeter method:
Disconnect all connectors affected, and check continuity in the wiring between adjacent connectors. When the ohmmeter indicates “infinite”, the wiring is open.

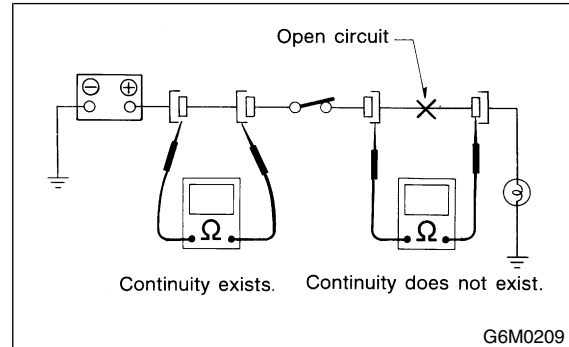

3. HOW TO DETERMINE AN OPEN CIRCUIT

S903627G5103

1) Voltmeter Method:

An open circuit is determined by measuring the voltage between respective connectors and ground using a voltmeter, starting with the connector closest to the power supply. The power supply must be turned ON so that current flows in the circuit. If voltage is not present between a particular connector and ground, the circuit between that connector and the previous connector is open.

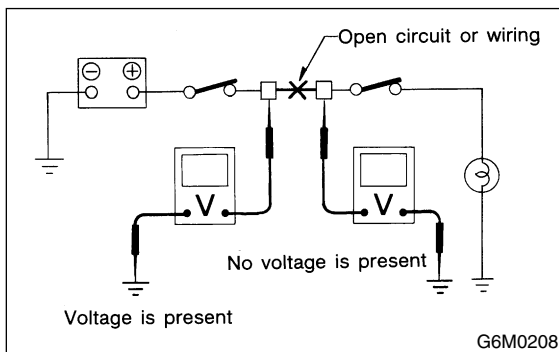

4. HOW TO DETERMINE A SHORT CIRCUIT

S903627G5104

1) Test lamp method:

Connect a test lamp (rated at approximately 3 watts) in place of the blown fuse and allow current to flow through the circuit. Disconnect one connector at a time from the circuit, starting with the one located farthest from the power supply. If the test lamp goes out when a connector is disconnected, the wiring between that connection and the next connector (farther from the power supply) is shorted.

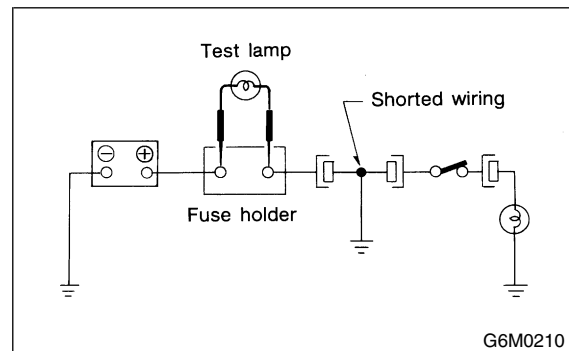

2) Ohmmeter method:

Disconnect all affected connectors, and check continuity between each connector and ground. When ohmmeter indicates continuity between a particular connector and ground, that connector is shorted.

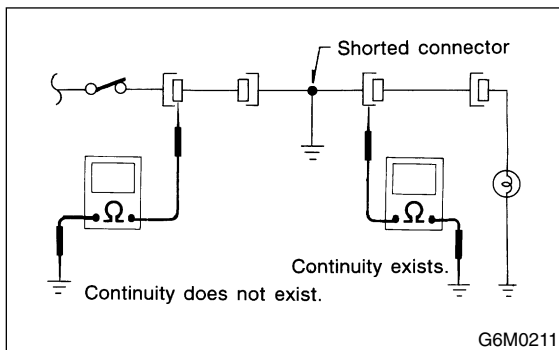

BASIC DIAGNOSTICS PROCEDURE

C: HOW TO READ WIRING DIAGRAMS S903627G52

1. WIRING DIAGRAM S903627G5201

The wiring diagram of each system is illustrated so that you can understand the path through which the electric current flows from the battery.

Sketches and codes are used in the diagrams. They should read as follows:

- Each connector and its terminal position are indicated by a sketch of the connector in a disconnected state which is viewed from the front.

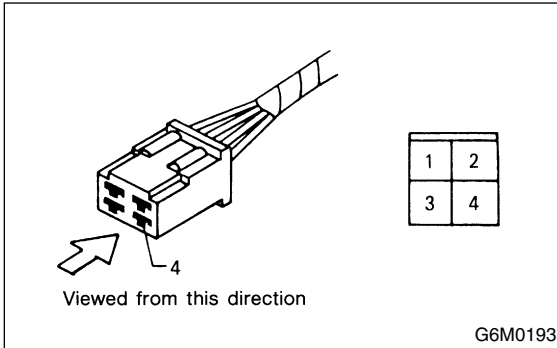

- The number of poles or pins, presence of a lock, and pin number of each terminal are indicated in the sketch of each connector. In the sketch, the highest pole number refers to the number of poles which the connector has. For example, the sketch of the connector shown in figure indicates the connector has 9 poles.

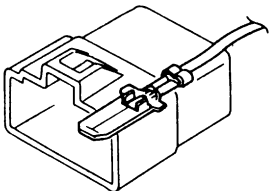
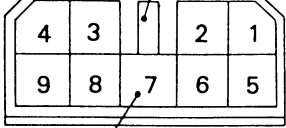
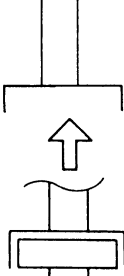
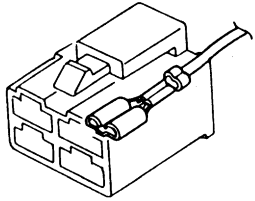
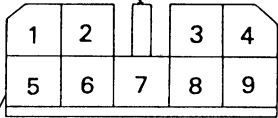
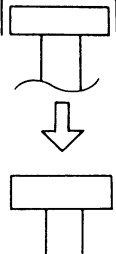
Connector used in vehicle	Connector shown in wiring diagram		
	Sketch	Symbol	Number of poles
 G6M0194	Double frames Indicates a lock is included.  Indicates the number of poles. G6M0196		Numbered in order from upper right to lower left.
 G6M0195	Indicates a lock is included.  Single frame G6M0197	 G6M0198	Numbered in order from upper left to lower right.

BASIC DIAGNOSTICS PROCEDURE

- When one set of connectors is viewed from the front side, the pole numbers of one connector are symmetrical to those of the other. When these two connectors are connected as a unit, the poles which have the same number are joined.

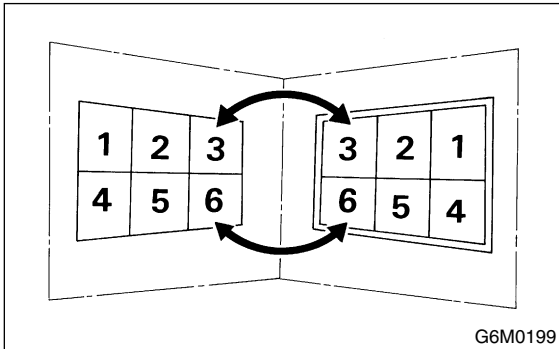

- Electrical wiring harness:**
The connectors are numbered along with the number of poles, external colors, and mating connections in the accompanying list.
- The sketch of each connector in the wiring diagram usually shows the (A) side of the connector. The relationship between the wire color, terminal number and connector is described in figure.

NOTE:

A wire which runs in one direction from a connector terminal sometimes may have a different color from that which runs in the other direction from that terminal.

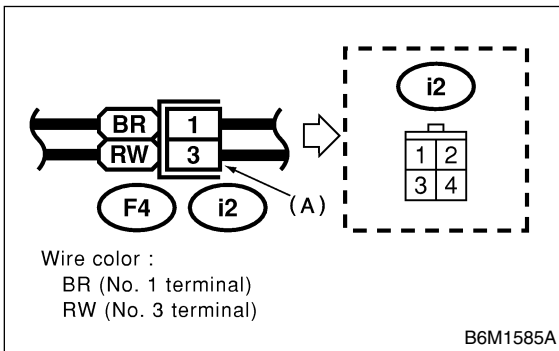

- In wiring diagram, connectors which have no terminal number refer to one-pole types. Sketches of these connectors are omitted intentionally.

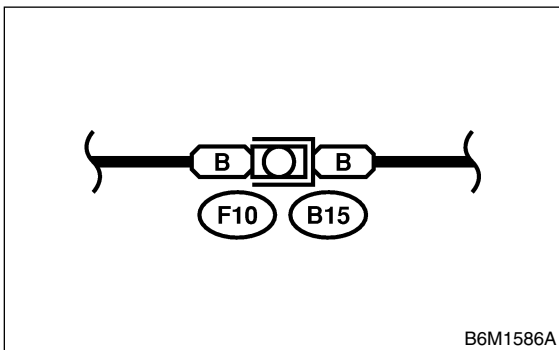

- The following color codes are used to indicate the colors of the wires used.

Color code	Color
L	Blue
B	Black
Y	Yellow
G	Green
R	Red
W	White
Br	Brown
Lg	Light green
Gr	Gray
P	Pink
Or	Orange
Lb	Light Blue
V	Violet
SA	Sealed (Inner)
SB	Sealed (Outer)

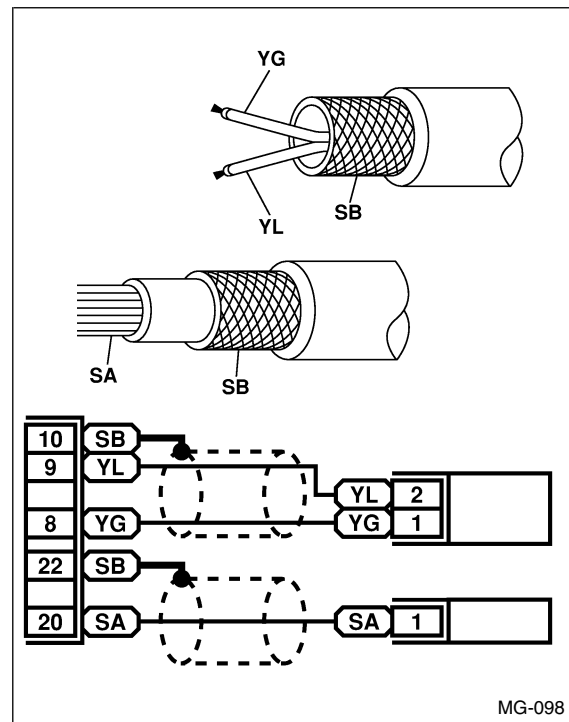

BASIC DIAGNOSTICS PROCEDURE

Wiring System

- The wire color code, which consists of two letters (or three letters including Br or Lg), indicates the standard color (base color of the wire covering) by its first letter and the stripe marking by its second letter.

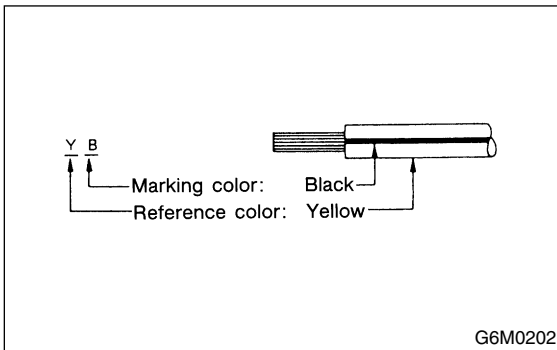

- The table lists the nominal sectional areas and allowable currents of the wires.

CAUTION:

When replacing or repairing a wire, be sure to use the same size and type of the wire which was originally used.

NOTE:

- The allowable current in the table indicates the tolerable amperage of each wire at an ambient temperature of 40°C (104°F).
- The allowable current changes with ambient temperature. Also, it changes if a bundle of more than two wires is used.

Nominal sectional area mm ²	No. of strands/ strand diameter	Outside diameter of finished wiring mm	Allowable current Amps/ 40°C (104°F)
0.3	7/0.26	1.8	7
0.5	7/0.32	2.2 (or 2.0)	12
0.75	30/0.18	2.6 (or 2.4)	16
0.85	11/0.32	2.4 (or 2.2)	16
1.25	16/0.32	2.7 (or 2.5)	21
2	26/0.32	3.1 (or 2.9)	28
3	41/0.32	3.8 (or 3.6)	38
5	65/0.32	4.6 (or 4.4)	51
8	50/0.45	5.5	67

- Each unit is directly grounded to the body or indirectly grounds through a harness ground terminal. Different symbols are used in the wiring diagram to identify the two grounding systems.

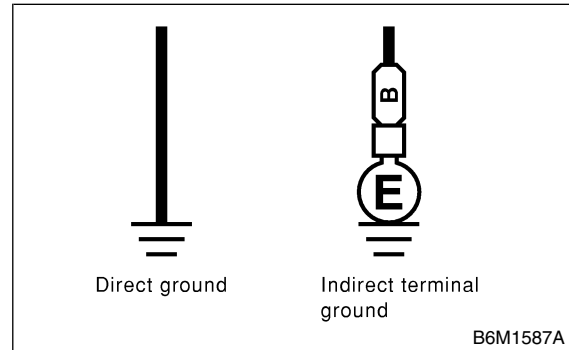

- The ground points shown in the wiring diagram refer to the following:

NOTE:

All wiring harnesses are provided with a ground point which should be securely connected.

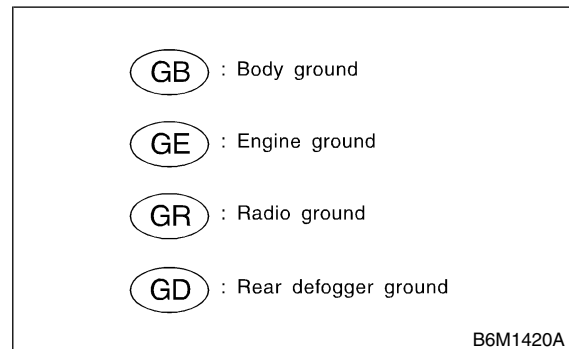

BASIC DIAGNOSTICS PROCEDURE

- Relays are classified as normally-open or normally-closed. The normally-closed relay has one or more contacts.
- The wiring diagram shows the relay mode when the energizing circuit is OFF.

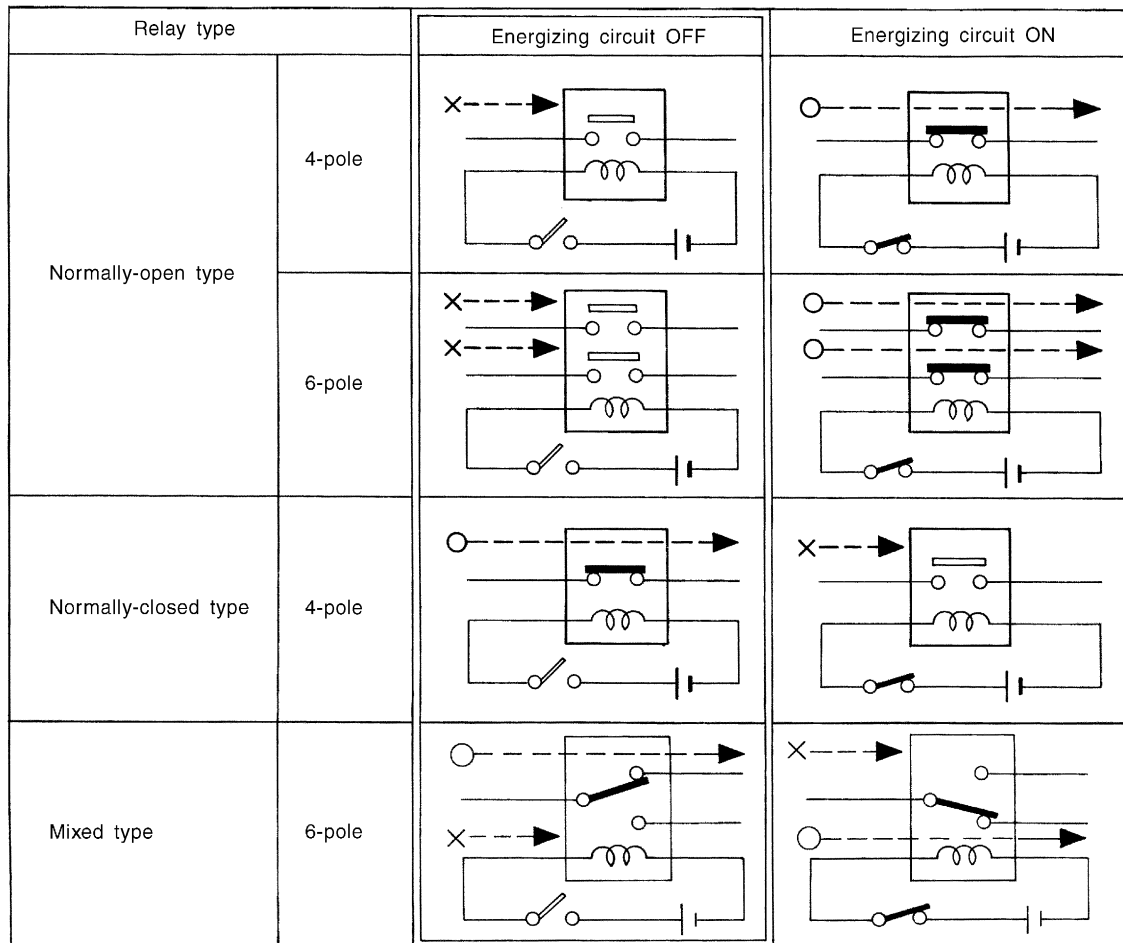

Key to symbols:

- —▶ : Current flows.
- × —▶ : Current does not flow.

BASIC DIAGNOSTICS PROCEDURE

Wiring System

- Each connector number shown in the wiring diagram corresponds to that in the wiring harness. The location of each connector in the actual vehicle is determined by reading the first character of the connector (for example, a "F" for F8, "i" for i16, etc.) and the type of wiring harness. The first character of each connector number refers to the area or system of the vehicle.

Symbol	Wiring harness and cord
F	Front wiring harness
B	Bulkhead wiring harness
E	Engine wiring harness
T	Transmission cord, Rear oxygen sensor cord
D	Door cord LH & RH, Rear door cord LH & RH, Rear gate cord
i	Instrument panel wiring harness
R	Rear wiring harness, Fuel tank cord, Roof cord, ORVR cord

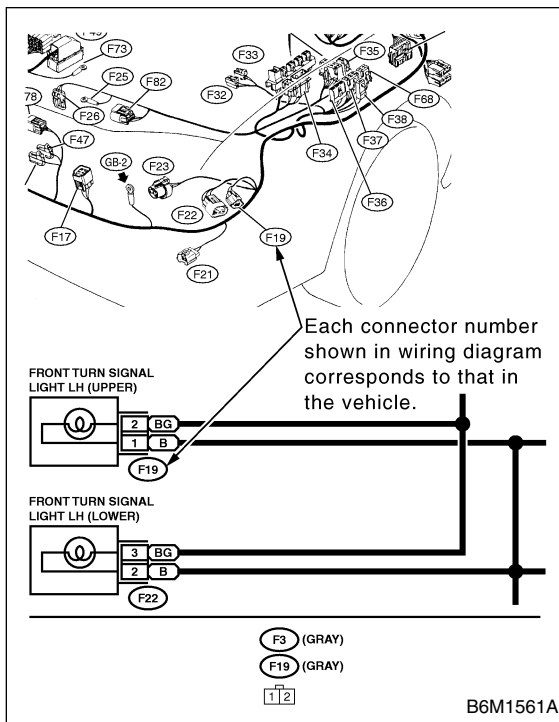

D: SYMBOLS IN WIRING DIAGRAMS S903627G53

A number of symbols are used in each wiring diagram to easily identify parts or circuits.

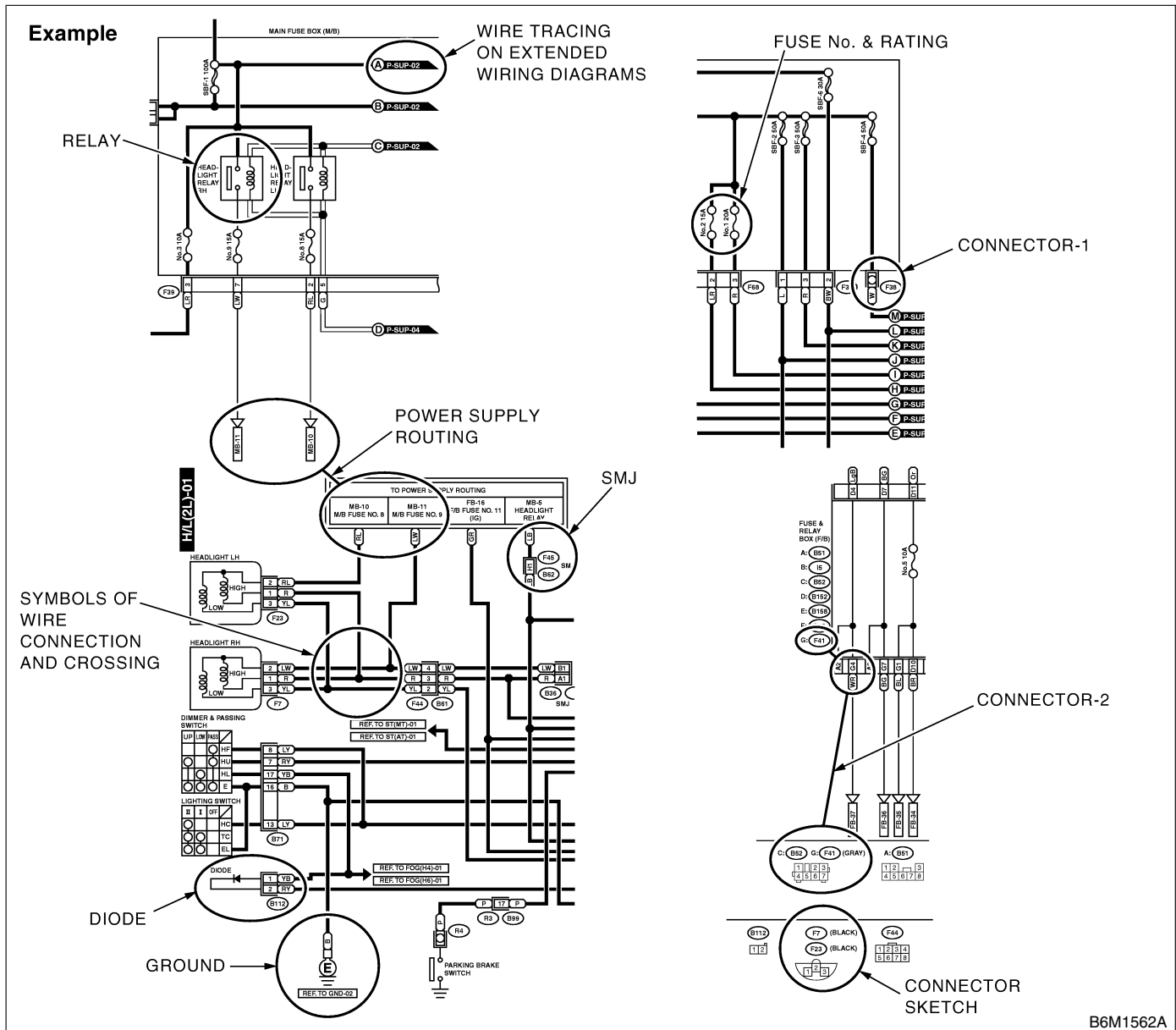

1. RELAY S903627G5301

A symbol used to indicate a relay.

2. CONNECTOR-1 S903627G5302

The sketch of the connector indicates the one-pole types.

3. WIRING CONNECTION S903627G5303

Some wiring diagrams are indicated in foldouts for convenience. Wiring destinations are indicated where necessary by corresponding symbols (as when two pages are needed for clear indication).

4. FUSE No. & RATING G903627G5304

The "FUSE No. & RATING" corresponds with that used in the fuse box (main fuse box, fuse and joint box).

5. CONNECTOR-2 S903627G5305

- Each connector is indicated by a symbol.
- Each terminal number is indicated in the corresponding wiring diagram in an abbreviated form.
- For example, terminal number "C2" refers to No. 2 terminal of connector (C: F41) shown in the connector sketch.

BASIC DIAGNOSTICS PROCEDURE

Wiring System

6. CONNECTOR SKETCH S903627G5306

- Each connector sketch clearly identifies the shape and color of a connector as well as terminal locations. Non-colored connectors are indicated in natural color.
- When more than two types of connector number are indicated in a connector sketch, it means that the same type connectors are used.

7. GROUND S903627G5307

Each grounding point can be located easily by referring to the corresponding wiring harness.

8. DIODE S903627G5308

A symbol is used to indicate a diode.

9. WIRE TRACING ON EXTENDED WIRING DIAGRAMS S903627G5309

For a wiring diagram extending over at least two pages, a symbol (consisting of the same characters with arrows), facilitates wire tracing from one page to the next.

A \longleftrightarrow A, B \longleftrightarrow B

10. SYMBOLS OF WIRE CONNECTION AND CROSSING S903627G5310

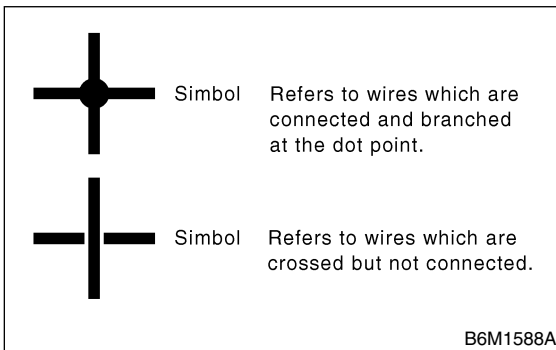

11. POWER SUPPLY ROUTING S903627G5311

A symbol is used to indicate the power supply in each wiring diagram.

“MB-5”, “MB-6”, etc., which are used as power-supply symbols throughout the text, correspond with those shown in the POWER SUPPLY ROUTING in the wiring diagram.

Accordingly, using the POWER SUPPLY ROUTING and wiring diagrams permits service personnel to understand the entire electrical arrangement of a system.

E: ABBREVIATION IN WIRING DIAGRAMS S903627G54

Abbr.	Full name
ABS	Antilock Brake System
ACC	Accessory
A/C	Air Conditioning
AD	Auto Down
A/S	Air suspension
AT	Automatic Transmission
AU	Auto Up
+B	Battery
DN	Down
E	Ground
F/B	Fuse & Joint Box
FL1.5	Fusible link 1.5 mm ²
IG	Ignition
Illumi.	Illumination
LH	Left Hand
Lo	Low
M	Motor
M/B	Main Fuse Box
MG	Magnet
Mi	Middle
OP	Optional Parts
PASS	Passing
RH	Right Hand
SBF	Slow Blow Fuse
ST	Starter
SW	Switch
UP	Up
WASH	Washer

2. Working Precautions S903706

A: PRECAUTIONS WHEN WORKING WITH THE PARTS MOUNTED ON THE VEHICLE S903706G38

- 1) When working under a vehicle which is jacked-up, always be sure to use safety stands.
- 2) The parking brake must always be applied during working. Also, in automatic transmission vehicles, keep the select lever set to the P (Parking) range.
- 3) Be sure the workshop is properly ventilated when running the engine. Further, be careful not to touch the belt or fan while the engine is operating.
- 4) Be careful not to touch hot metal parts, especially the radiator and exhaust system immediately after the engine has been shut off.

B: PRECAUTIONS IN TROUBLE DIAGNOSIS AND REPAIR OF ELECTRIC PARTS S903706G39

- 1) The battery cable must be disconnected from the battery's (-) terminal, and the ignition switch must be set to the OFF position, unless otherwise required by the diagnostics.
- 2) Securely fasten the wiring harness with clamps and slips so that the harness does not interfere with the body end parts or edges and bolts or screws.
- 3) When installing parts, be careful not to catch them on the wiring harness.
- 4) When disconnecting a connector, do not pull the wires, but pull while holding the connector body.

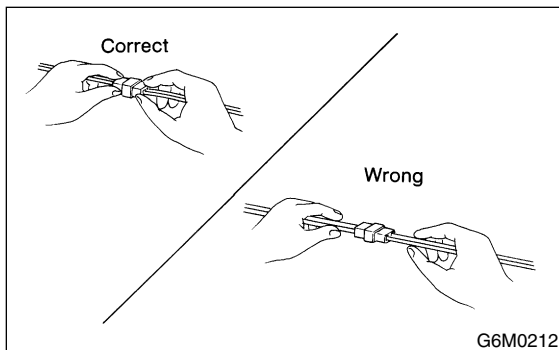

- 5) Some connectors are provided with a lock. One type of such a connector is disconnected by pushing the lock, and the other, by moving the lock up. In either type the lock shape must be identified before attempting to disconnect the connector. To connect, insert the connector until it snaps and confirm that it is tightly connected.

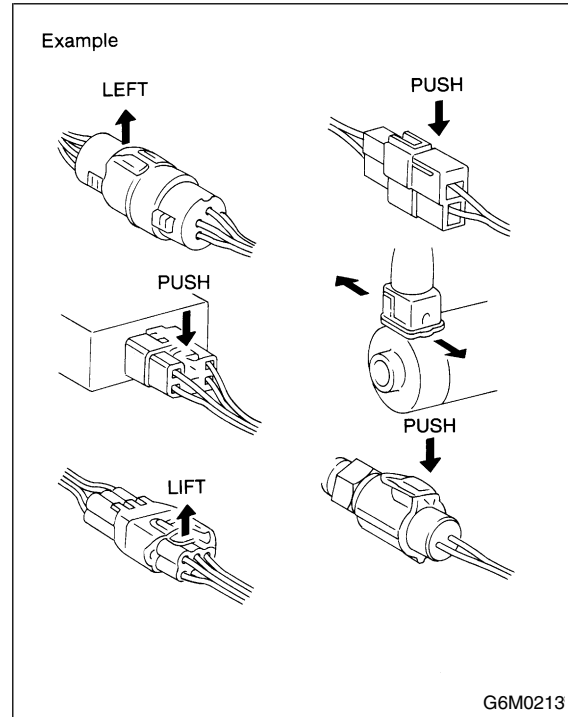

- 6) When checking continuity between connector terminals, or measuring voltage across the terminal and ground, always contact tester probe(s) on terminals from the wiring connection side. If the probe is too thick to gain access to the terminal, use "mini" test leads.

To check water-proof connectors (which are not accessible from the wiring side), contact test probes on the terminal side being careful not to bend or damage the terminals.

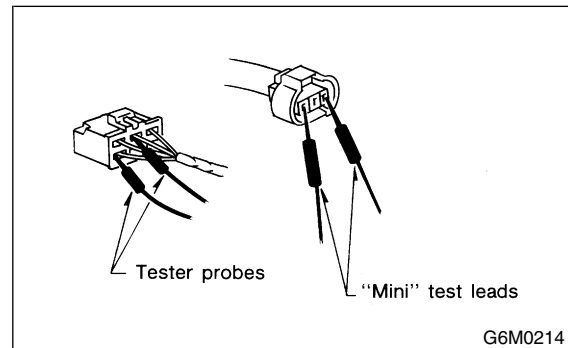

- 7) Sensors, relays, electrical unit, etc., are sensitive to strong impacts. Handle them with care so that they are not dropped or mishandled.

SUPER MULTIPLE JUNCTION (SMJ)

Wiring System

3. Super Multiple Junction (SMJ) S903464

A: HOW TO USE SUPER MULTIPLE JUNCTION (SMJ) S903464G40

The "SMJ" indicated in wiring diagrams is shown in a simplified form.

B: TERMINAL ARRANGEMENT S903464G41

Bulkhead Wiring Harness ← → Front Wiring Harness

B62 66 Poles

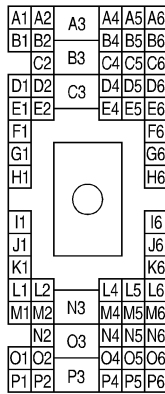

F45 66 Poles

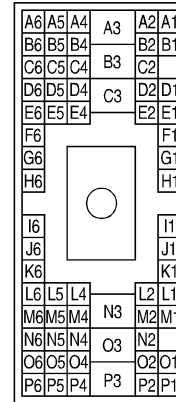

Bulkhead Wiring Harness ← → Instrument Panel Wiring Harness

B36 66 Poles

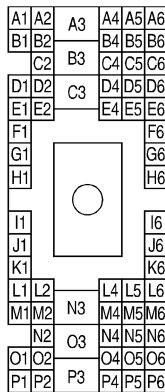

i1 66 Poles

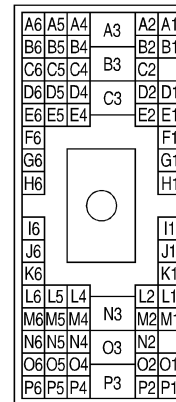

B6M1280A

C: INSTALLATION S903464A11

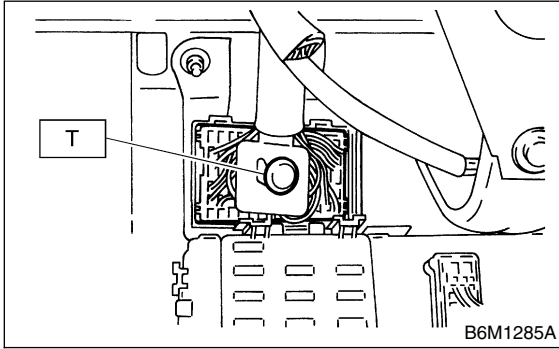

Tightening torque:
T: 4.4 N·m (0.45 kgf·m, 3.3 ft·lb)

NOTE:

- Align the cutout portion of one connector with that of other before tightening the connecting bolt.
- Do not tighten the bolt excessively since this may deform the connectors.

D: EXPLANATION OF SMJ SHOWN IN THE WIRING DIAGRAM S903464G42

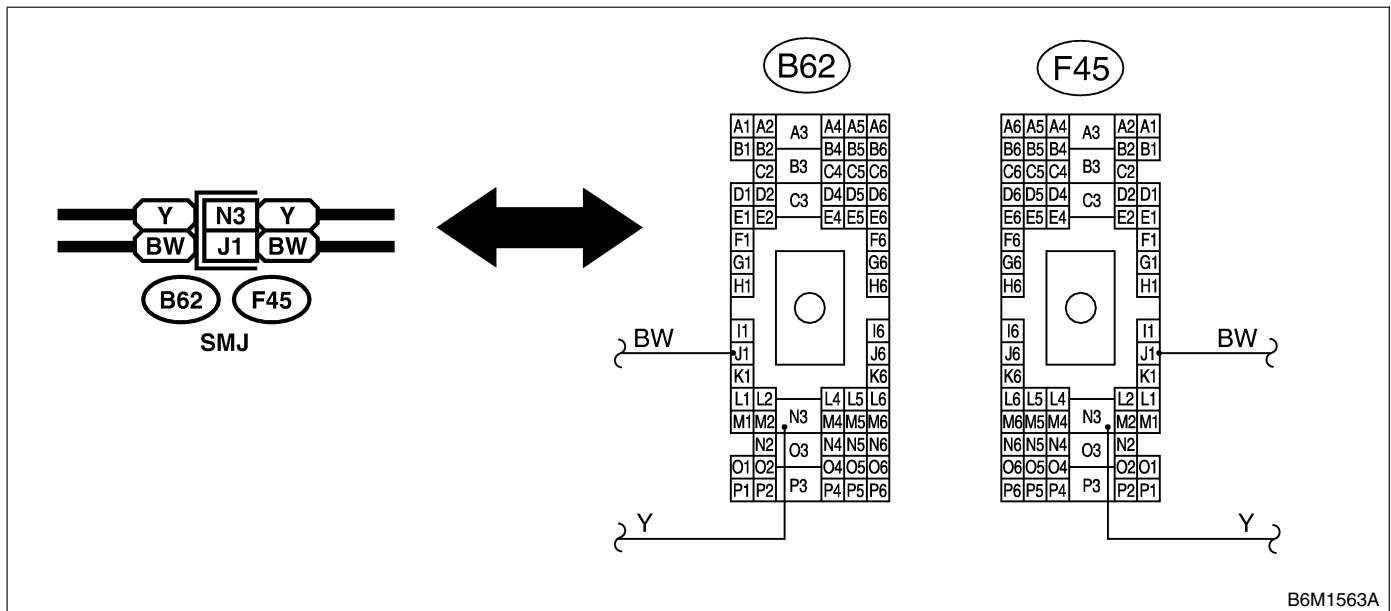

SUPER MULTIPLE JUNCTION (SMJ)

Wiring System

MEMO:

4. Power Supply Routing

S903465

A: SCHEMATIC

S903465A21

1. LHD MODEL

S903465A2101

P-SUP(L)-01

P-SUP(L)-01

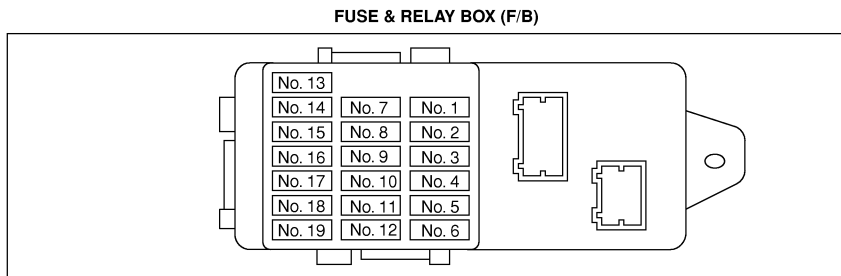
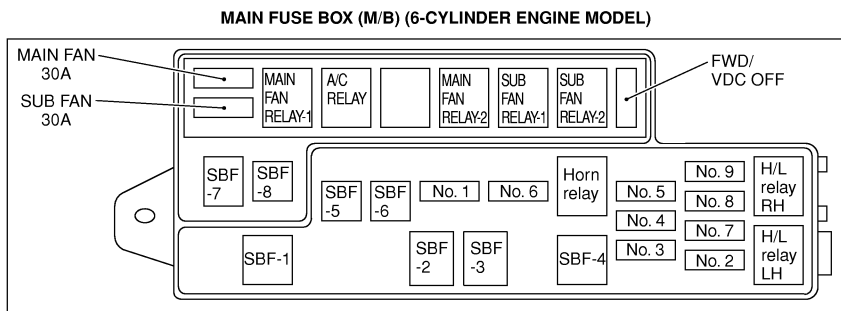
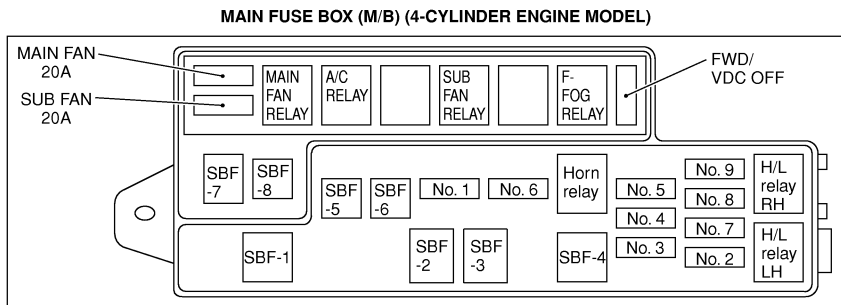

POWER SUPPLY ROUTING

Wiring System

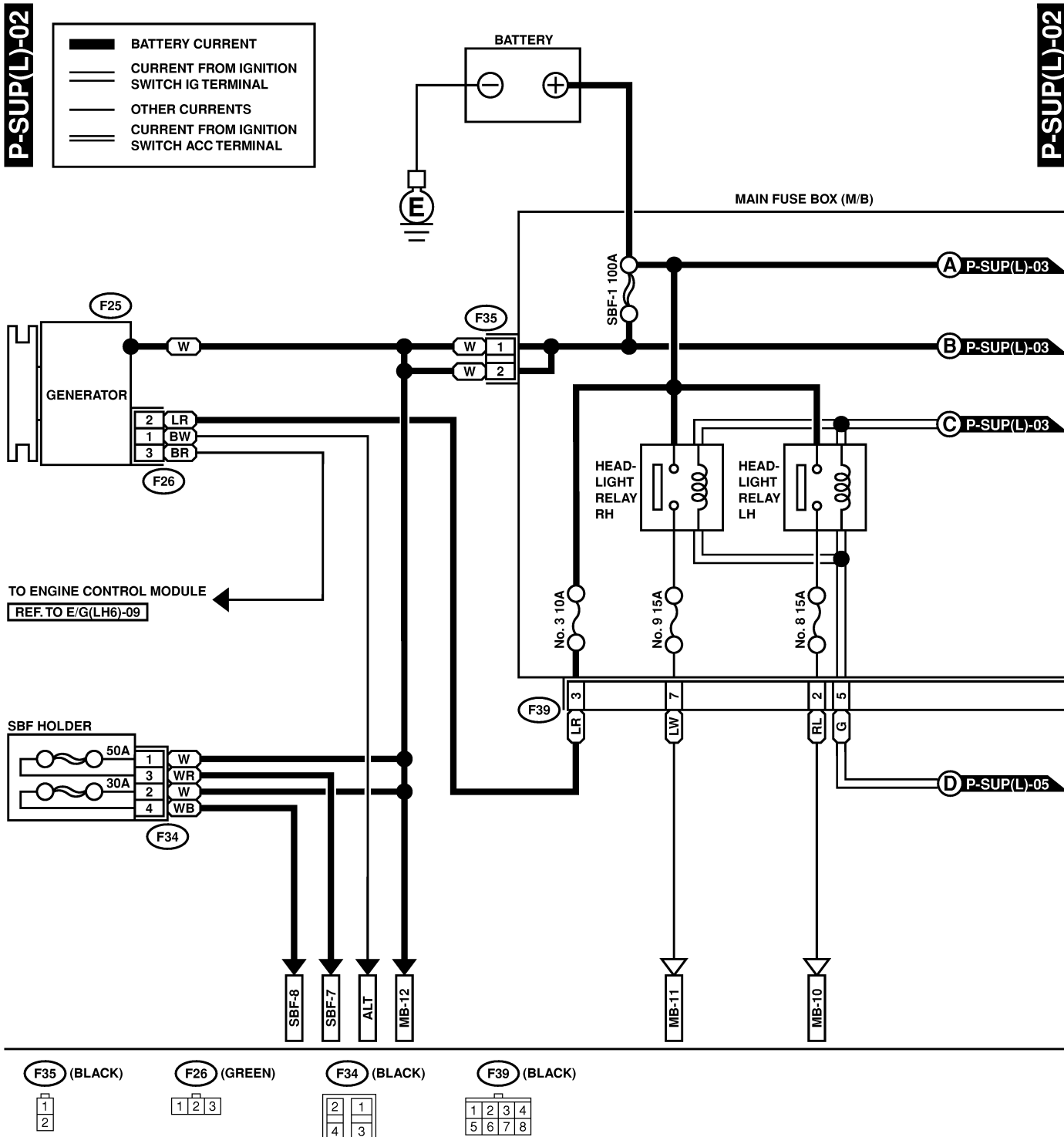

POWER SUPPLY ROUTING

Wiring System

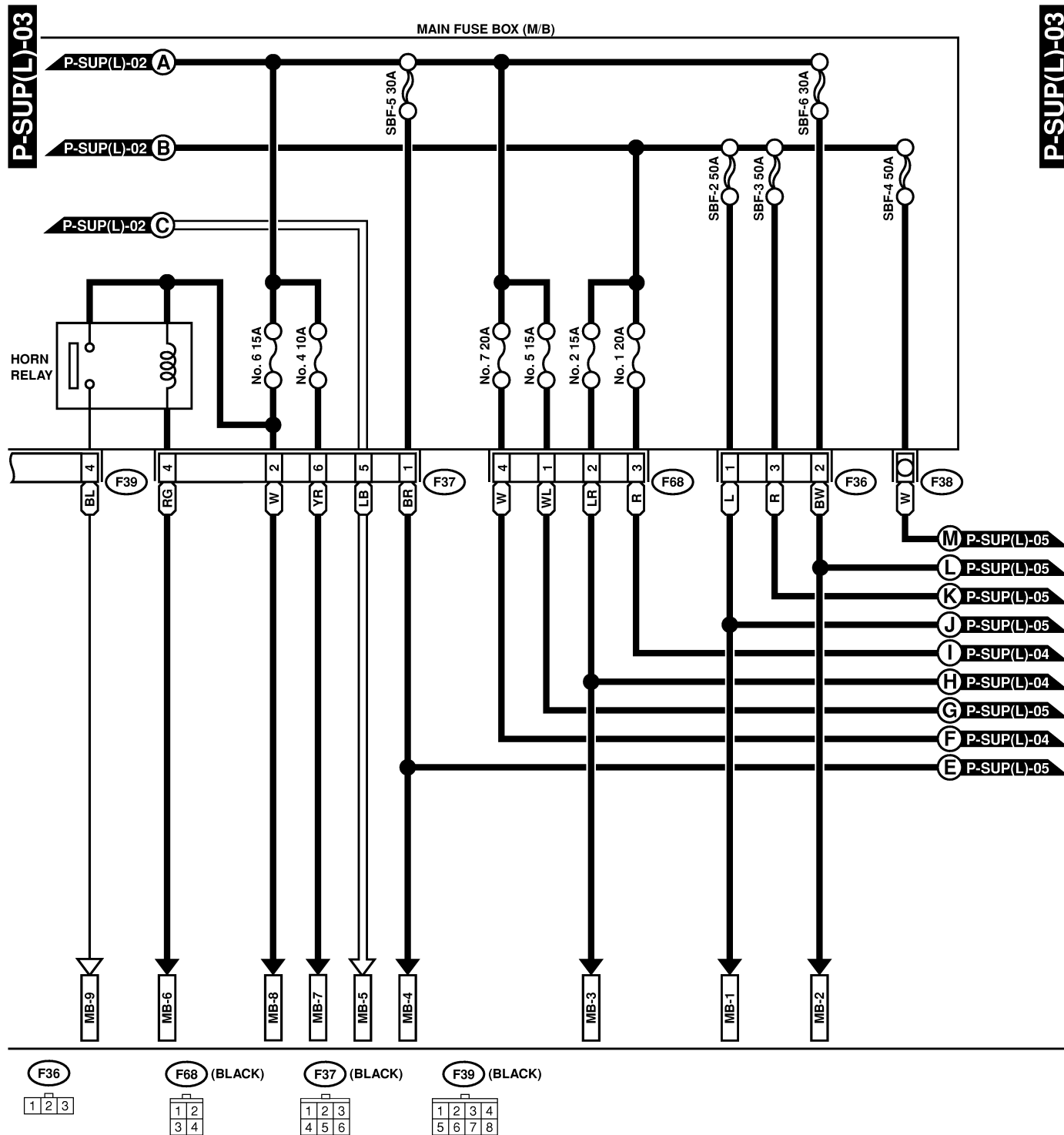

POWER SUPPLY ROUTING

Wiring System

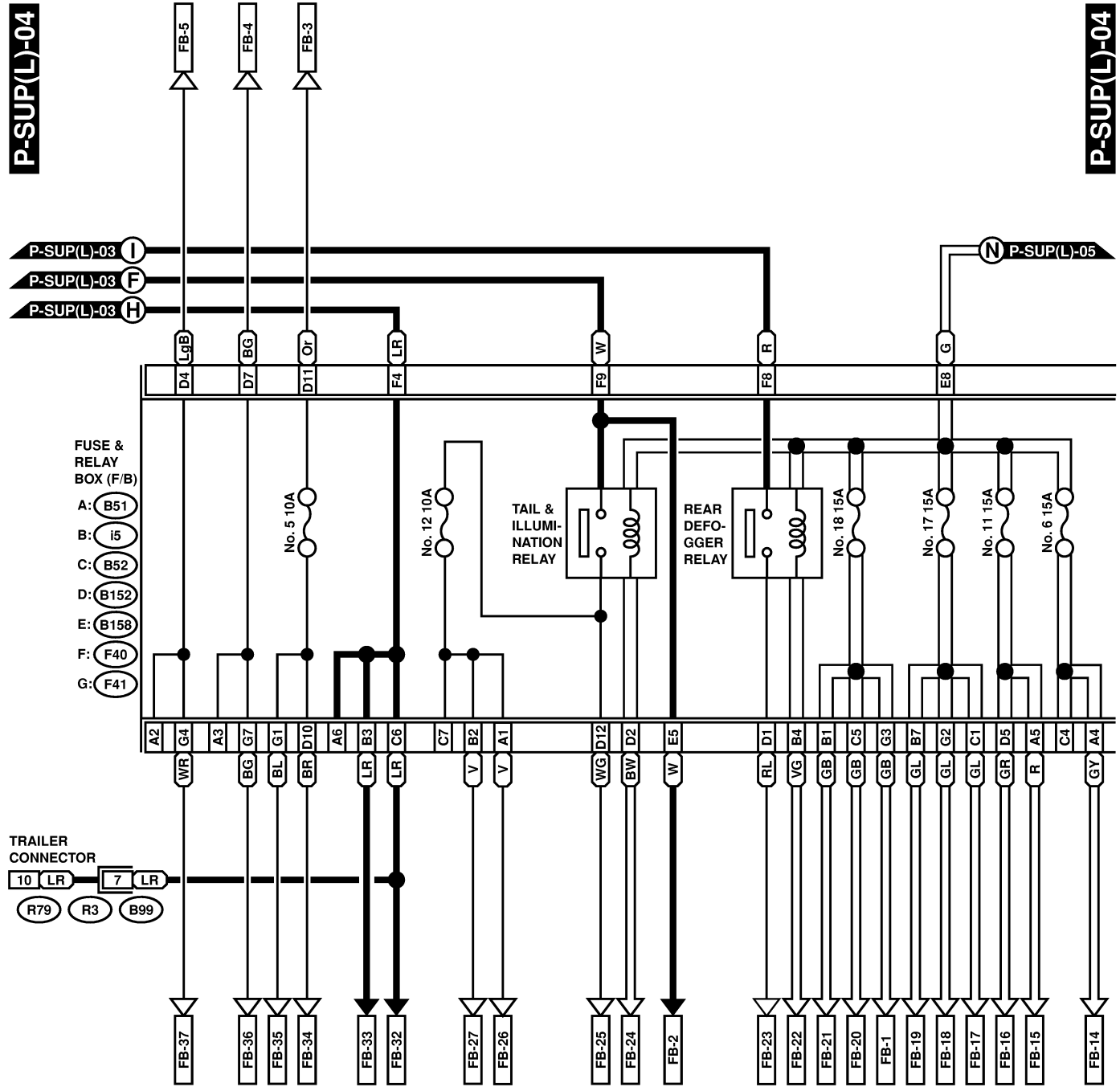

C: B52

G: F41 (GRAY)

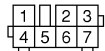

A: B51 (BLUE)

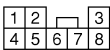

F: F40 (BROWN)

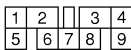

E: B158 (GRAY)

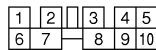

R79

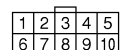

B: i5 (BLUE)

D: B152

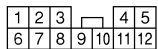

B99

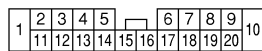

POWER SUPPLY ROUTING

Wiring System

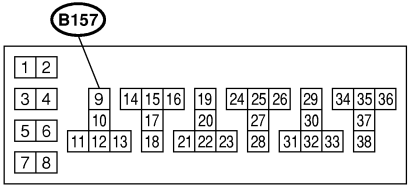
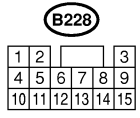
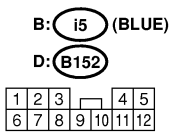
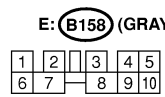
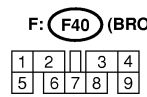
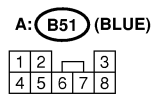
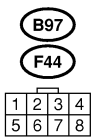
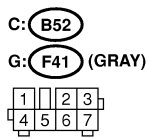
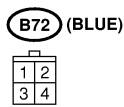
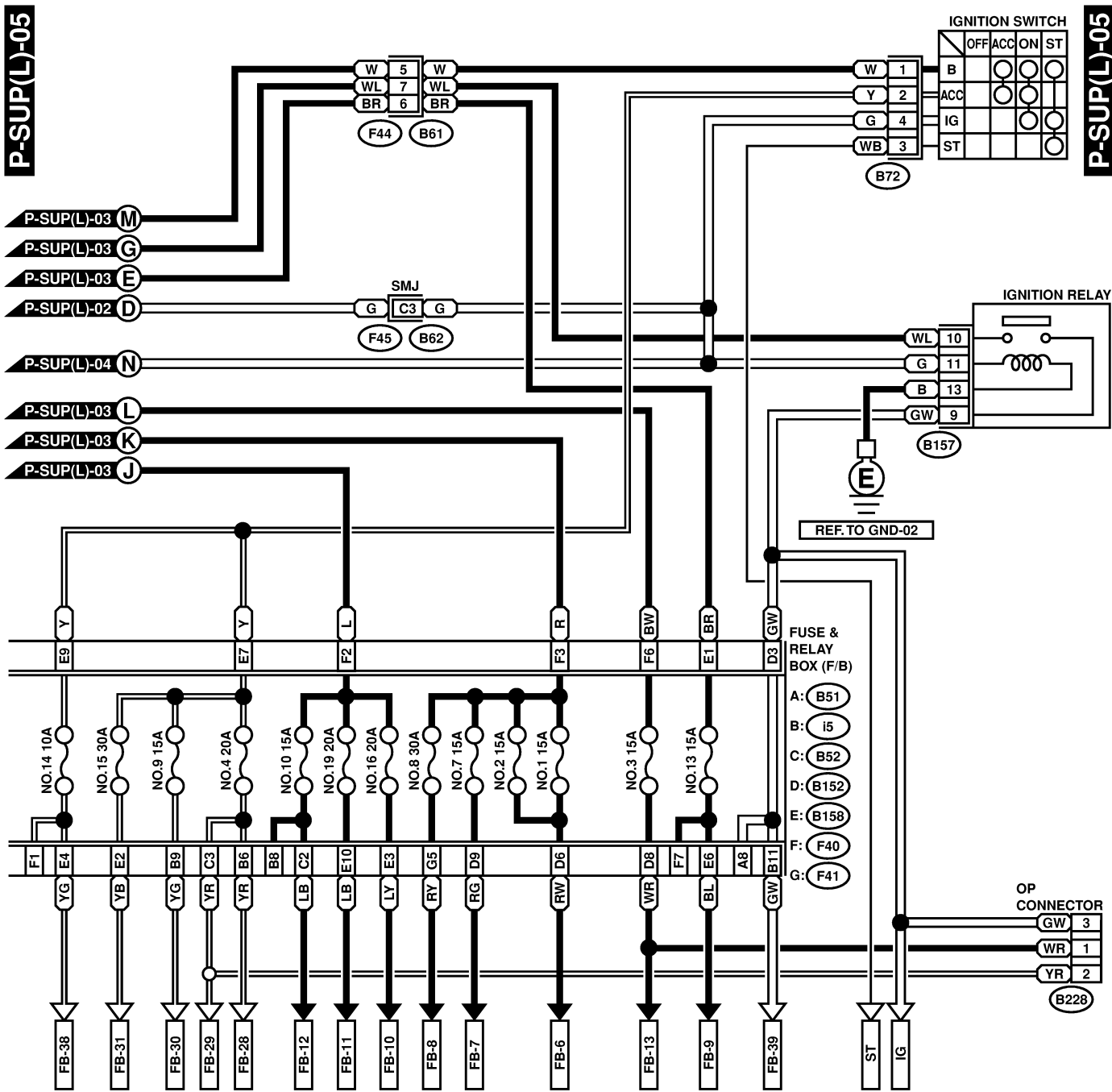

RELAY BLOCK (BLACK)

POWER SUPPLY ROUTING

Wiring System

No.	Load
MB-1	Fuse (Relay block)
MB-2	Power window circuit breaker
MB-4	Data link connector Engine control module Immobiliser control module Main relay
MB-5	Diode (With rear fog light) Lighting switch OP connector
MB-6	Cruise control sub switch Horn switch
MB-7	A/S control module Transmission control module
MB-8	Hazard switch Keyless entry control module Key warning switch
MB-9	Horn
MB-10	Headlight LH
MB-11	Combination meter Headlight RH
MB-12	A/C relay holder
SBF-7	ABS control module VDC hydraulic module
SBF-8	A/S compressor & discharge solenoid
ALT	A/S control module Combination meter
IG	Check connector Seat belt timer Vehicle speed sensor (MT)
ST	Engine control module Inhibitor switch (AT) Starter motor (MT)
FB-1	ABS control module Main fan relay (4-cylinder engine model) Main fan relay-1 (6-cylinder engine model) Main fan relay-2 (6-cylinder engine model) VDC module
FB-2	Parking switch
FB-3	Parking switch
FB-4	Combination meter Hazard switch Rear turn signal light LH Trailer connector Turn signal switch
FB-5	Combination meter Hazard switch Rear turn signal light RH Trailer connector Turn signal switch
FB-6	Blower motor relay
FB-7	Front fog light relay
FB-8	ABS control module VDC hydraulic module
FB-9	Fuel pump relay
FB-10	Stop light switch
FB-11	Wiper deicer relay

No.	Load
FB-12	A/S compressor relay A/S compressor & discharge solenoid A/S solenoid Rear fog light relay
FB-13	Door lock timer Keyless entry control module
FB-14	Airbag control module
FB-15	Airbag control module
FB-16	Engine control module Fuel pump relay Ignition coil (6-cylinder engine model) Ignition coil and ignitor (4-cylinder engine model) Immobiliser control module Transmission control module
FB-17	A/C pressure switch Blower motor relay Fan relay (6-cylinder engine model)
FB-18	A/C relay Sub fan relay (4-cylinder engine model) Sub fan relay-1 (6-cylinder engine model) Sub fan relay-2 (6-cylinder engine model)
FB-19	Auto A/C control module Mode control panel (Manual A/C)
FB-20	A/S control module Back-up light switch (MT) Cruise control module Height control switch Inhibitor switch (AT) Power window relay Wiper deicer relay Wiper deicer timer
FB-21	Cruise control main switch
FB-22	Engine control module Rear defogger switch
FB-23	Rear defogger Rear defogger condenser
FB-24	Engine control module Lighting switch OP connector
FB-25	Headlight leveler LH Headlight leveler RH Headlight leveling switch Parking switch
FB-26	Front fog light relay Illumination control module Illumination light OP connector Rear fog light relay
FB-27	Combination meter Front fog light switch Headlight leveling switch Illumination light Rear fog light switch
FB-28	Auto A/C control module Front accessory power supply socket

POWER SUPPLY ROUTING

Wiring System

No.	Load
FB-29	Mirror heater LH Mirror heater RH Remote control rearview mirror switch Seat heater/rear accessory power supply relay Vanity mirror illumination light LH Vanity mirror illumination light RH
FB-30	Radio
FB-31	Front washer motor Front wiper motor Front wiper & washer switch
FB-32	Door lock timer Keyless entry control module Key switch illumination light Luggage room light (Wagon) Trunk room light (Sedan) Room light Spot light
FB-33	Auto A/C control module Combination meter Radio
FB-34	License plate light LH License plate light RH Rear finisher light LH Rear finisher light RH Tail light LH Tail light RH Trailer connector
FB-35	Front clearance light LH Front clearance light RH
FB-36	Front turn signal light LH Side turn signal light LH
FB-37	Front turn signal light RH Side turn signal light RH
FB-38	Rear washer motor Rear wiper intermittent module Rear wiper motor
FB-39	Combination meter Hazard switch

POWER SUPPLY ROUTING

Wiring System

MEMO:

2. RHD MODEL S903465A2102

P-SUP(R)-01

P-SUP(R)-01

MAIN FUSE BOX (M/B) (4-CYLINDER ENGINE MODEL)

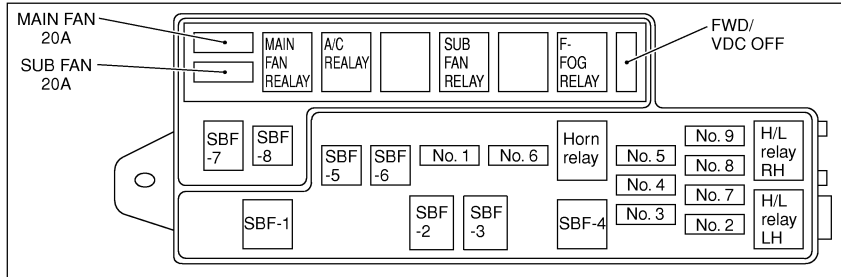

MAIN FUSE BOX (M/B) (6-CYLINDER ENGINE MODEL)

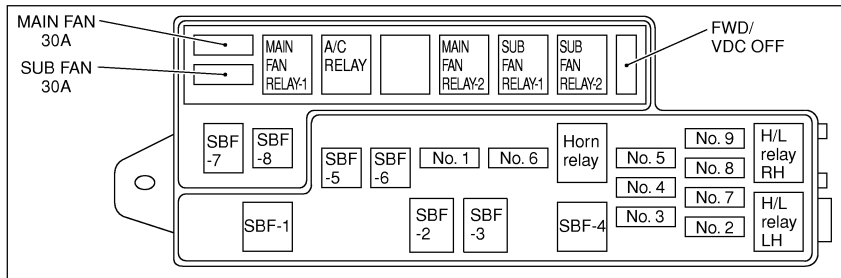

FUSE & RELAY BOX (F/B)

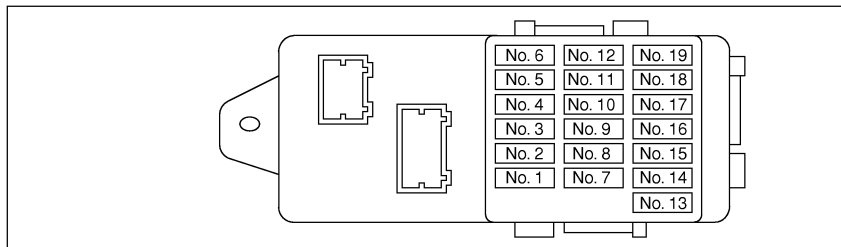

POWER SUPPLY ROUTING

Wiring System

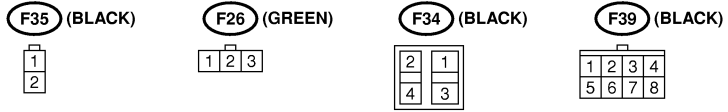
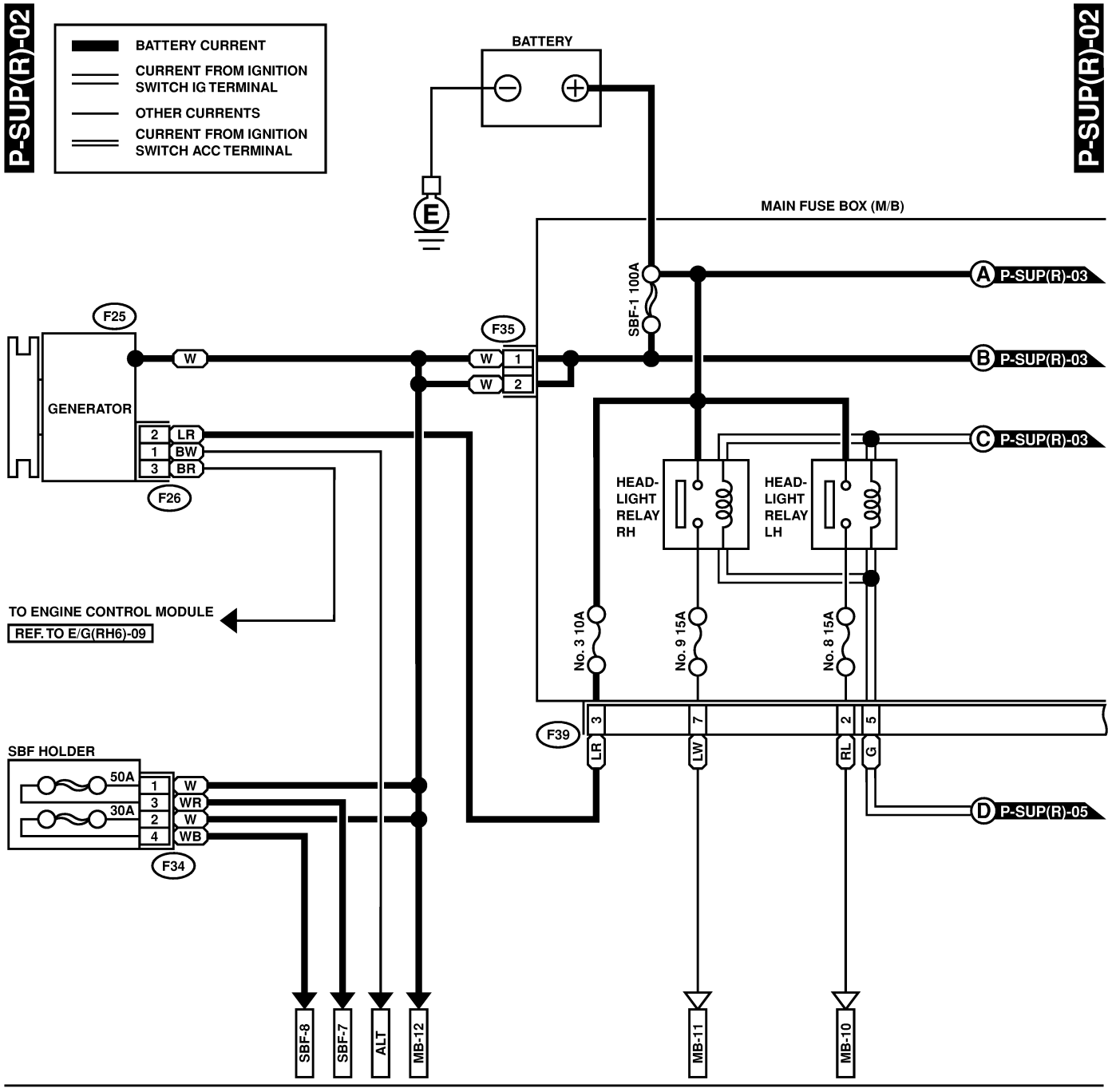

POWER SUPPLY ROUTING

Wiring System

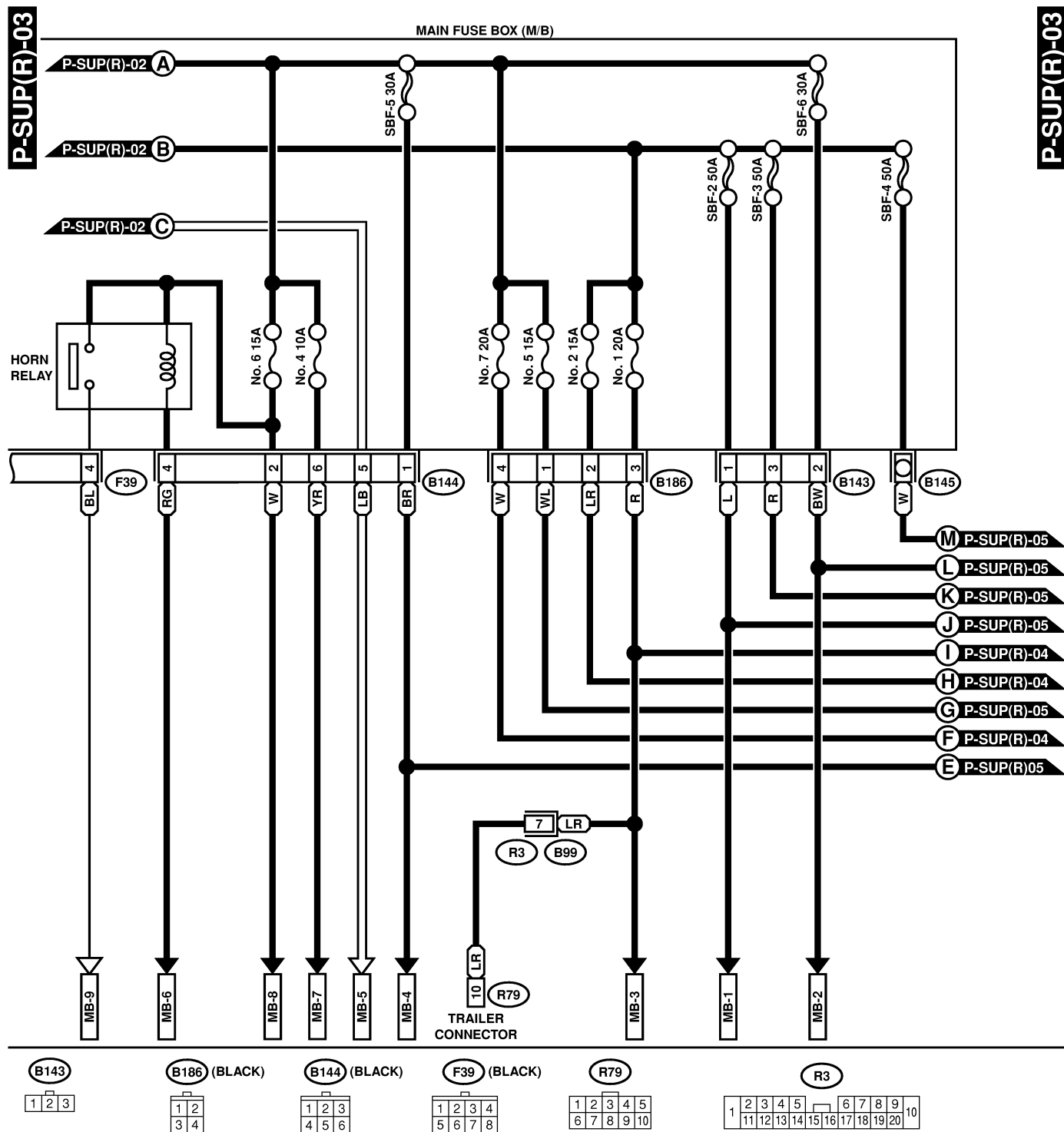

POWER SUPPLY ROUTING

Wiring System

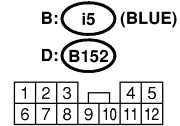
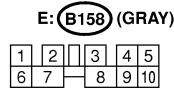
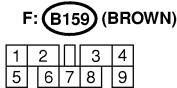
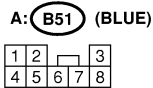
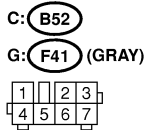
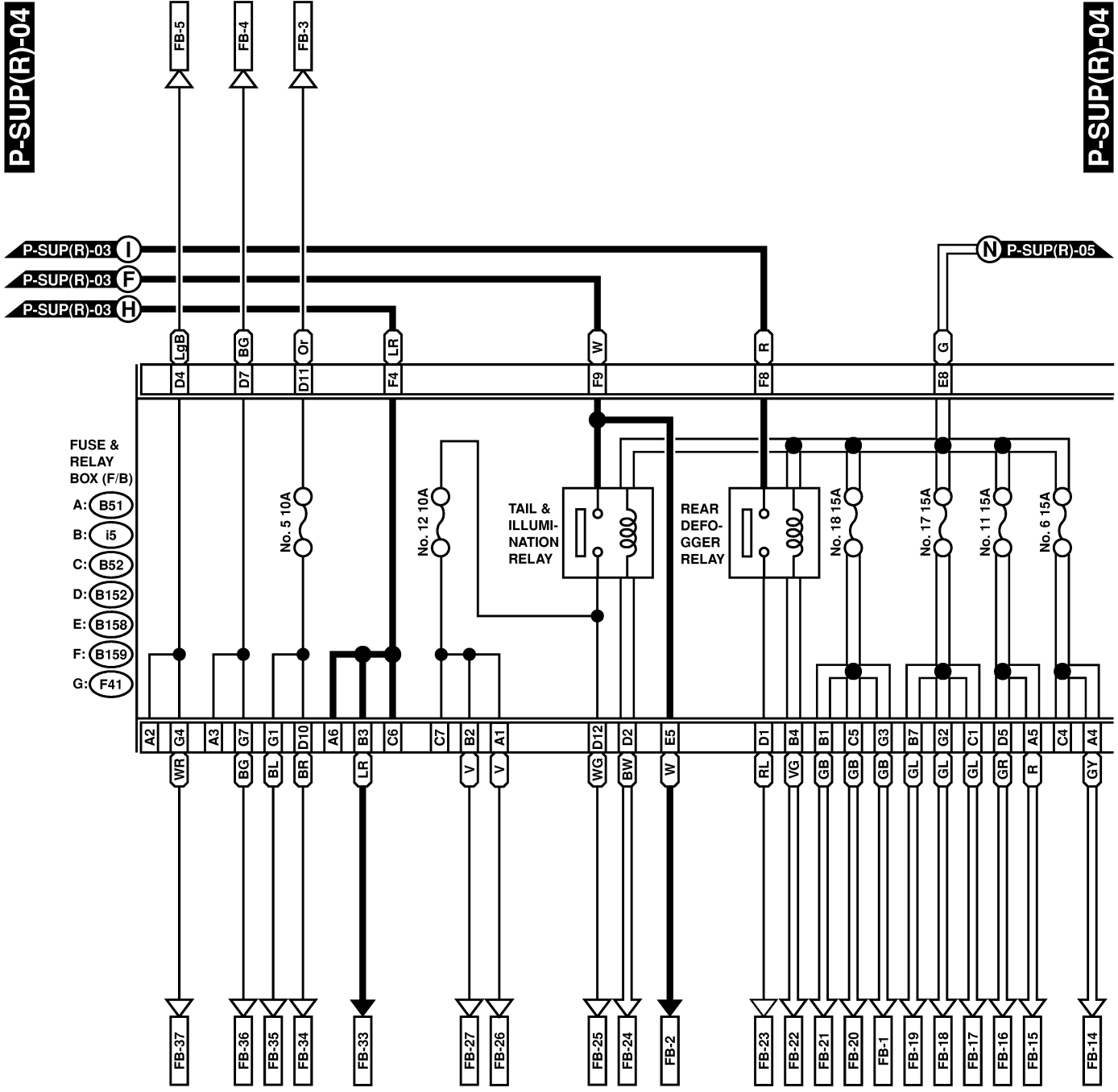

POWER SUPPLY ROUTING

Wiring System

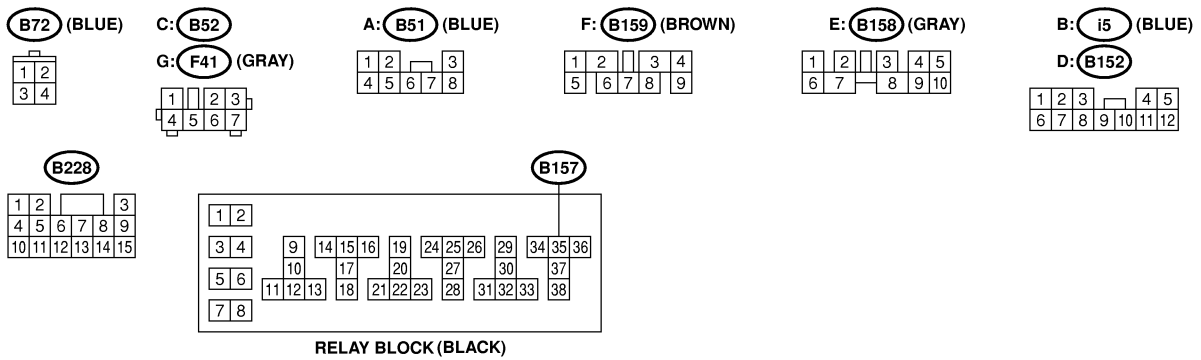
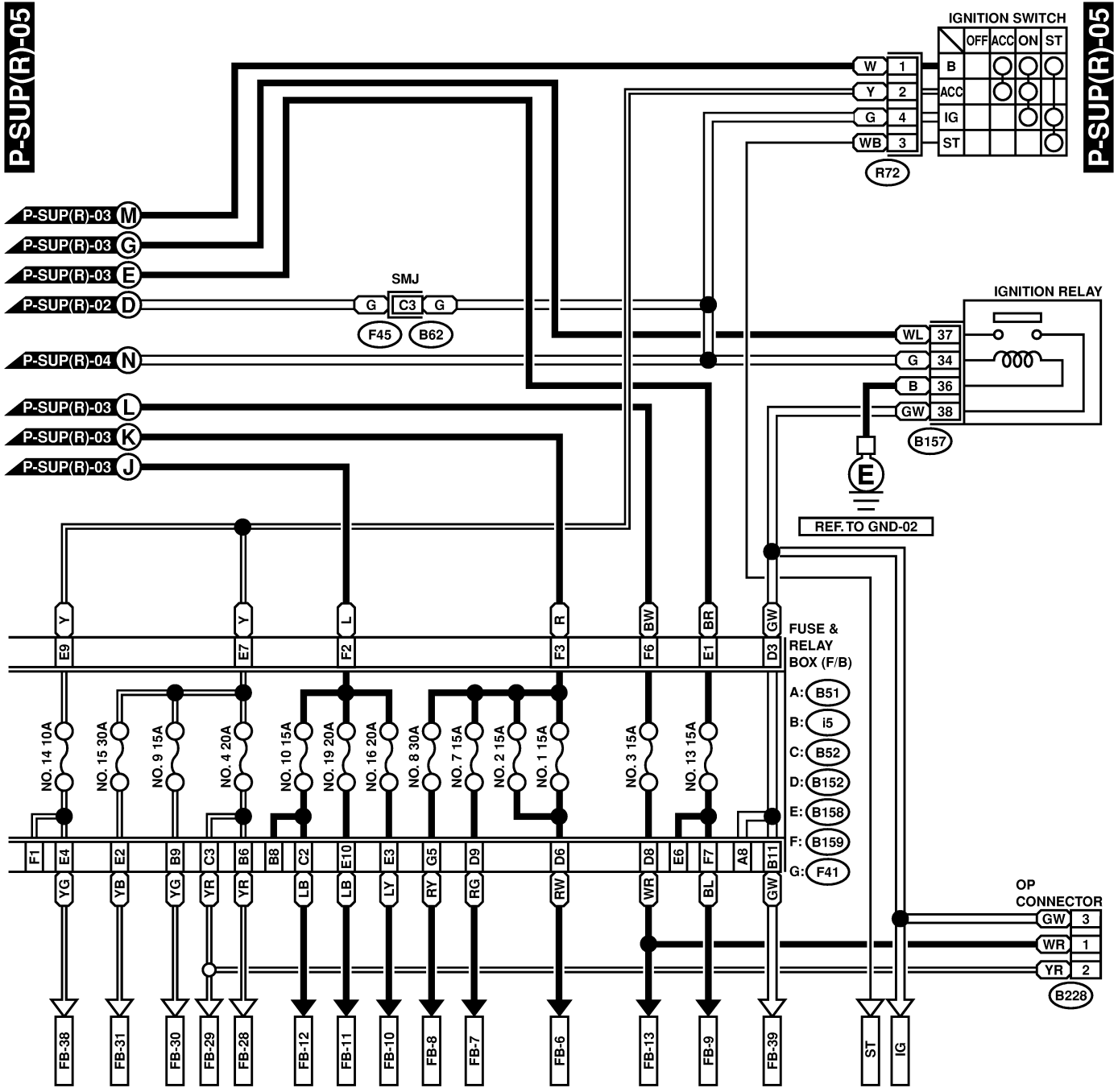

POWER SUPPLY ROUTING

Wiring System

No.	Load
MB-1	Fuse (Relay block) Seat heater relay
MB-2	Power window circuit breaker
MB-3	Door lock timer Keyless entry control module Key switch illumination light Luggage room light (Wagon) Trunk room light (Sedan) Room light Spot light
MB-4	Data link connector Engine control module Immobiliser control module Main relay
MB-5	Diode (With rear fog light) Lighting switch OP connector
MB-6	Cruise control sub switch Horn switch
MB-7	A/S control module Transmission control module
MB-8	Hazard switch Keyless entry control module Key warning switch
MB-9	Horn
MB-10	Headlight LH
MB-11	Combination meter Headlight RH
MB-12	A/C relay holder
SBF-7	ABS control module VDC hydraulic module
SBF-8	A/S compressor & discharge solenoid
ALT	A/S control module Combination meter
IG	Check connector Vehicle speed sensor (MT)
ST	Engine control module Inhibitor switch (AT) Starter motor (MT)
FB-1	ABS control module Main fan relay (4-cylinder engine model) Main fan relay-1 (6-cylinder engine model) Main fan relay-2 (6-cylinder engine model) VDC module
FB-2	Parking switch
FB-3	Parking switch
FB-4	Combination meter Hazard switch Rear turn signal light LH Side turn signal light LH Trailer connector Turn signal switch
FB-5	Combination meter Hazard switch Rear turn signal light RH Trailer connector Turn signal switch

No.	Load
FB-6	Blower motor relay
FB-7	Front fog light relay
FB-8	ABS control module VDC hydraulic module
FB-9	Fuel pump relay
FB-10	Stop light switch
FB-11	Wiper deicer relay
FB-12	A/S compressor relay A/S compressor & discharge solenoid A/S solenoid Rear fog light relay
FB-13	Door lock timer Keyless entry control module
FB-14	Airbag control module
FB-15	Airbag control module
FB-16	Engine control module Fuel pump relay Ignition coil (6-cylinder engine model) Ignition coil and ignitor (4-cylinder engine model) Immobiliser control module Transmission control module
FB-17	Blower motor relay Fan relay (6-cylinder engine model) FRESH/RESORT actuator Mode actuator
FB-18	A/C pressure switch A/C relay Sub fan relay (4-cylinder engine model) Sub fan relay-1 (6-cylinder engine model) Sub fan relay-2 (6-cylinder engine model)
FB-19	Auto A/C control module Blower module (Auto A/C) Mode control panel (Manual A/C)
FB-20	A/S control module Back-up light switch (MT) Cruise control module Height control switch Inhibitor switch (AT) Power window relay Wiper deicer relay Wiper deicer timer
FB-21	Cruise control main switch
FB-22	Engine control module Rear defogger switch
FB-23	Rear defogger Rear defogger condenser
FB-24	Engine control module Lighting switch OP connector
FB-25	Headlight leveler LH Headlight leveler RH Headlight leveling switch Parking switch

POWER SUPPLY ROUTING

Wiring System

No.	Load
FB-26	Front fog light relay Illumination control module Illumination light OP connector Rear fog light relay
FB-27	Combination meter Front fog light switch Headlight leveling switch Illumination light Rear fog light switch
FB-28	Auto A/C control module Front accessory power supply socket
FB-29	Mirror heater LH Mirror heater RH Remote control rearview mirror switch Seat heater/rear accessory power supply relay Vanity mirror illumination light LH Vanity mirror illumination light RH
FB-30	Radio
FB-31	Front washer motor Front wiper motor Front wiper & washer switch

No.	Load
FB-33	Auto A/C control module Combination meter Radio
FB-34	License plate light LH License plate light RH Rear finisher light LH Rear finisher light RH Tail light LH Tail light RH Trailer connector
FB-35	Front clearance light LH Front clearance light RH
FB-36	Front turn signal light LH
FB-37	Front turn signal light RH Side turn signal light RH
FB-38	Rear washer motor Rear wiper intermittent module Rear wiper motor
FB-39	Combination meter Hazard switch

GROUND DISTRIBUTION

Wiring System

5. Ground Distribution

S903472

A: SCHEMATIC

S903472A21

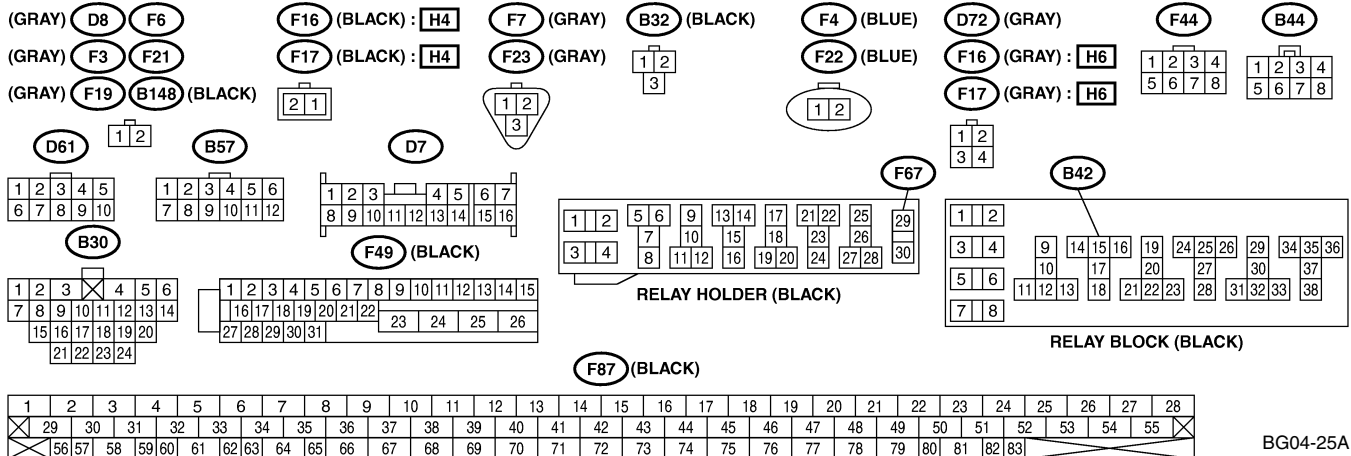
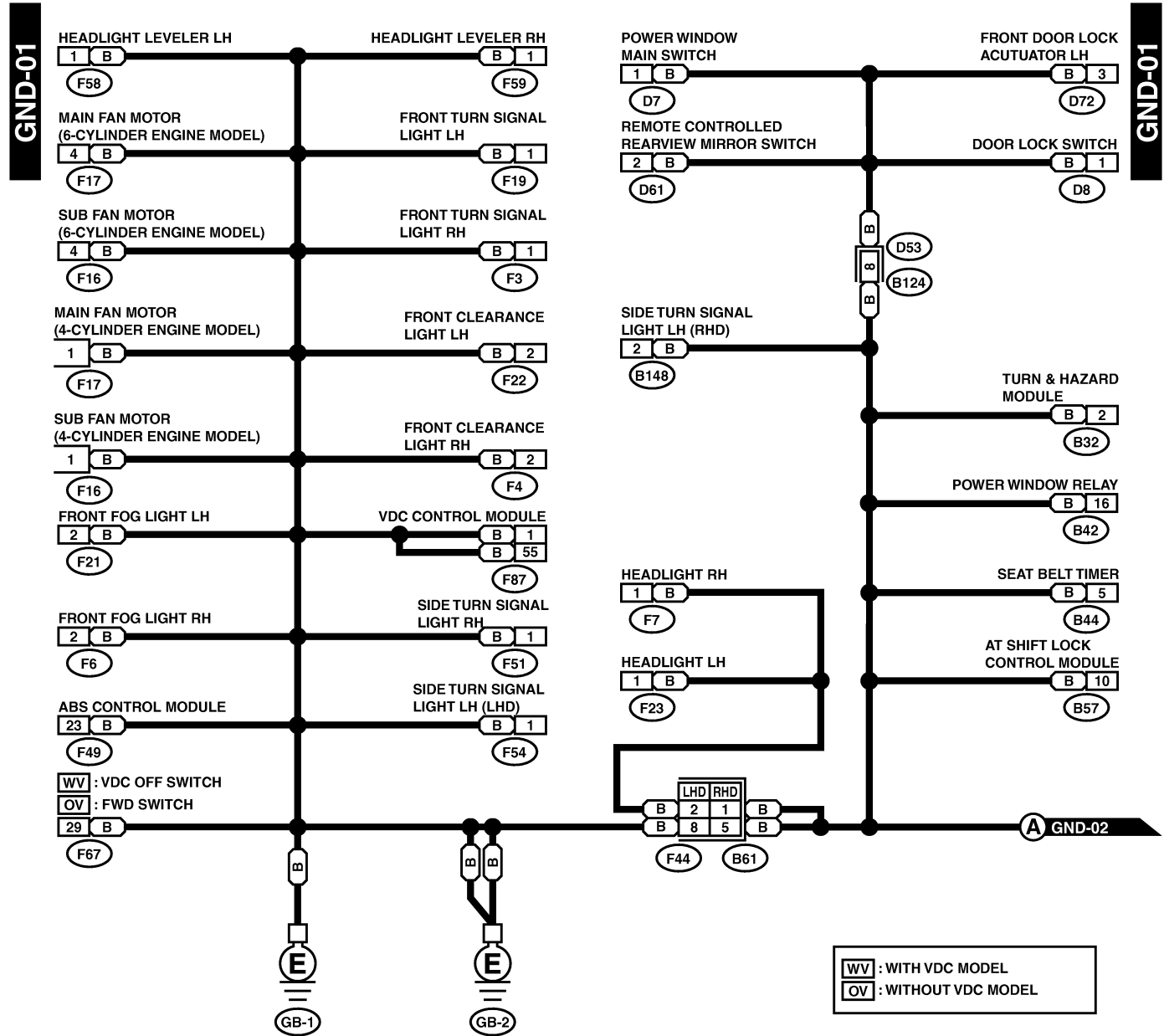

BG04-25A

GROUND DISTRIBUTION

Wiring System

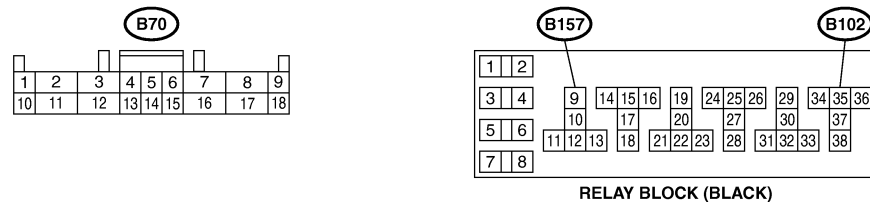
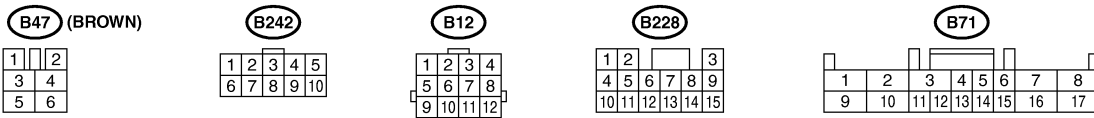
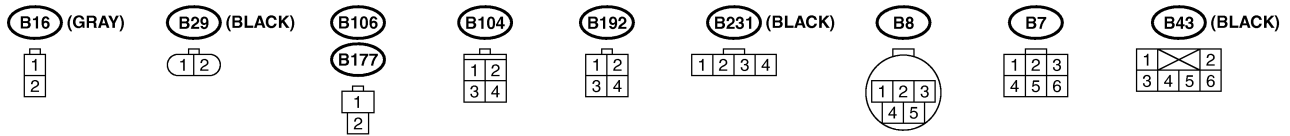
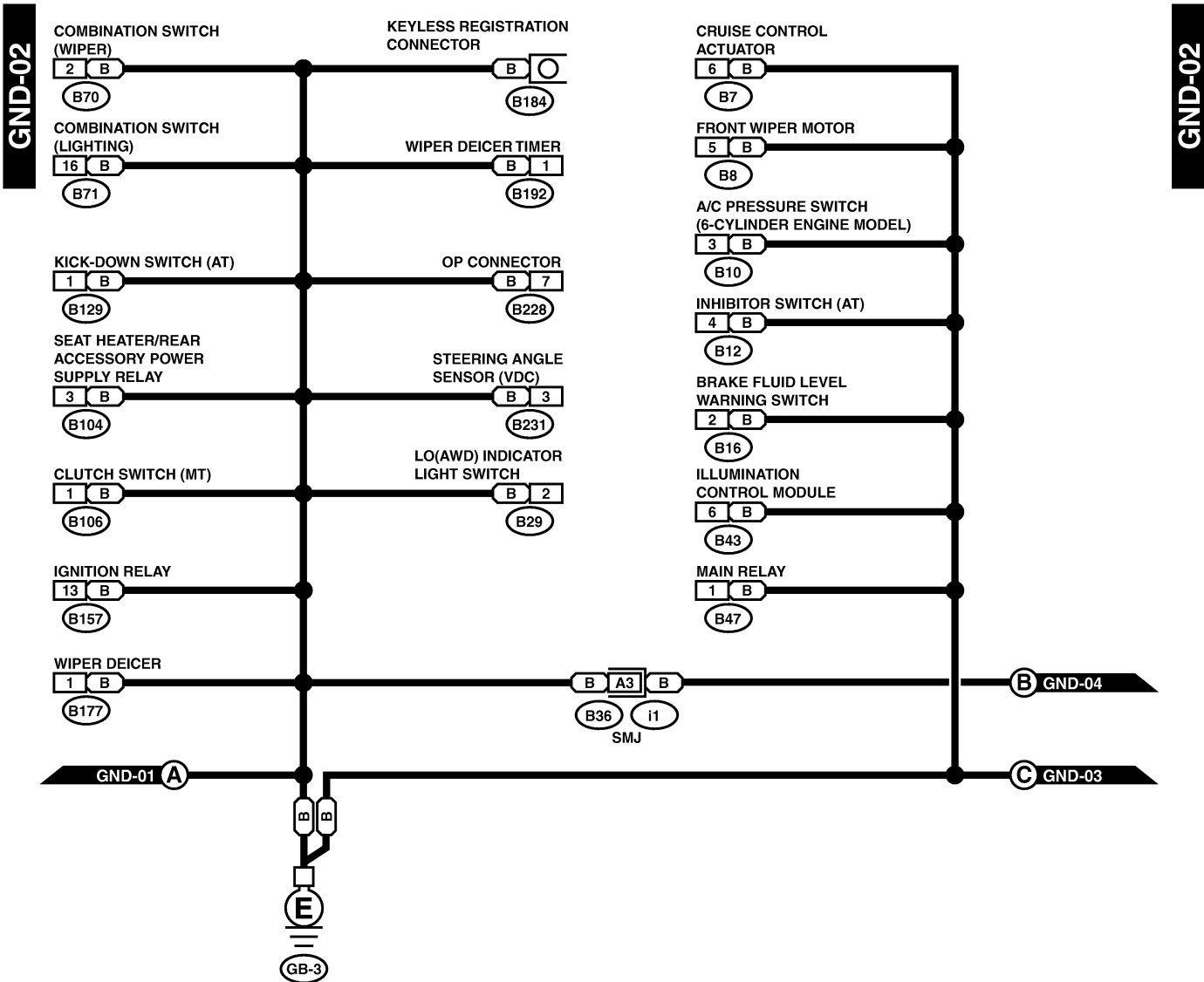

GROUND DISTRIBUTION

Wiring System

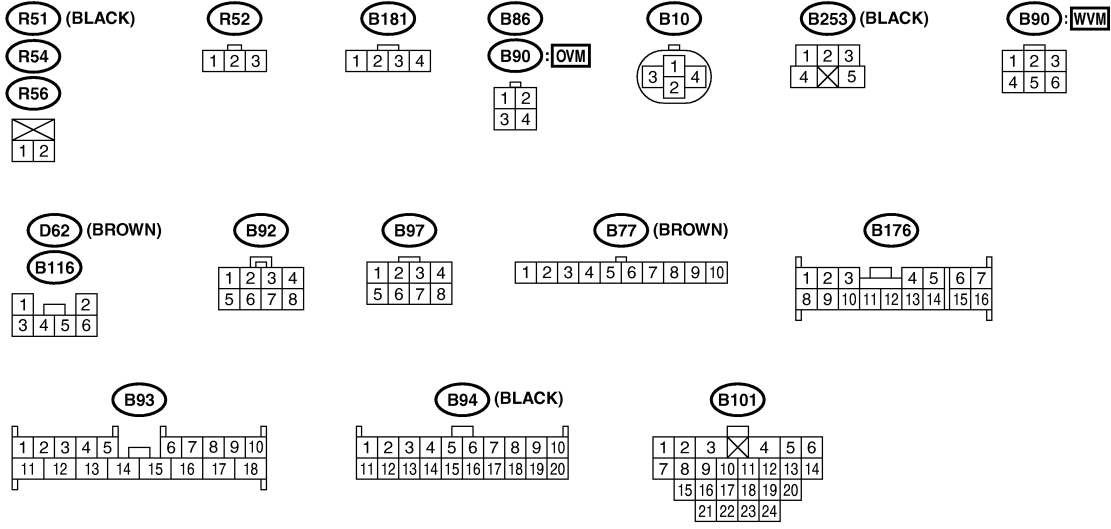
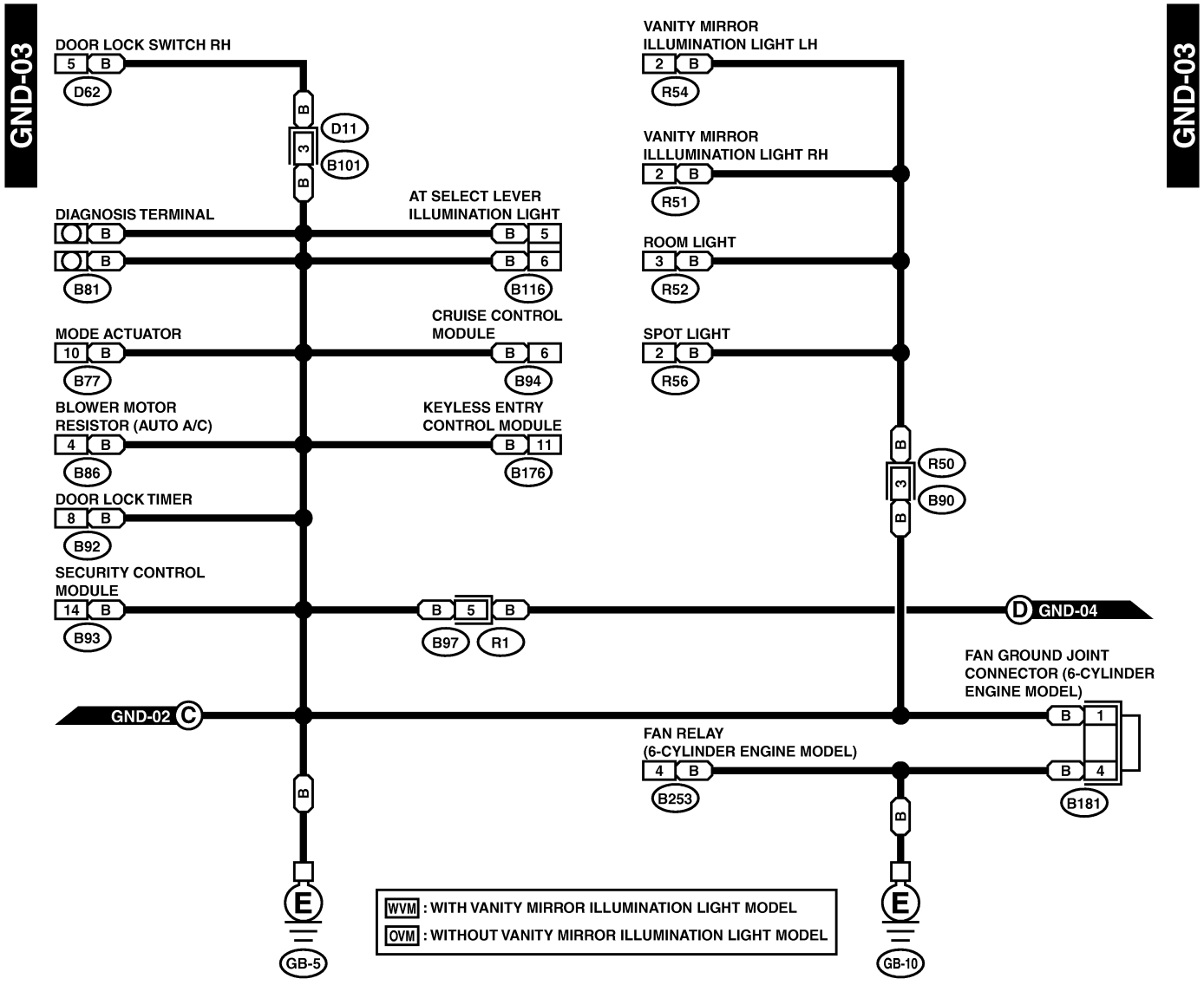

GROUND DISTRIBUTION

Wiring System

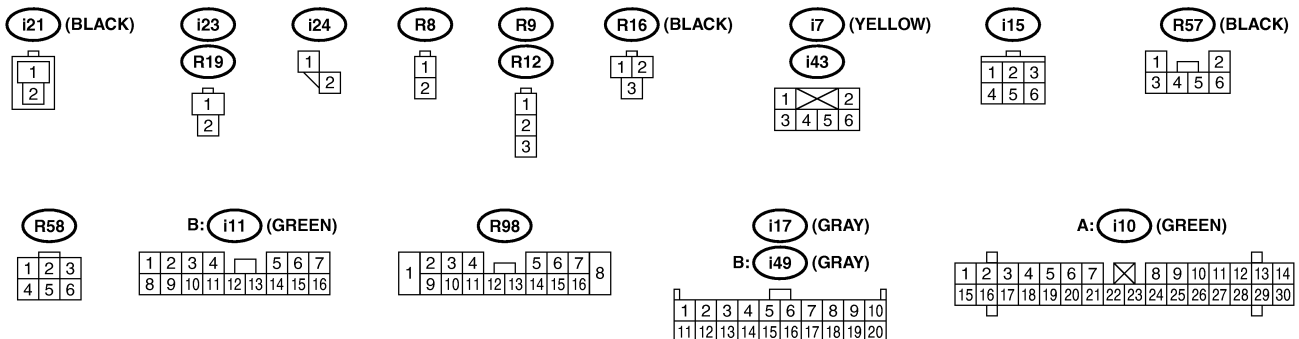
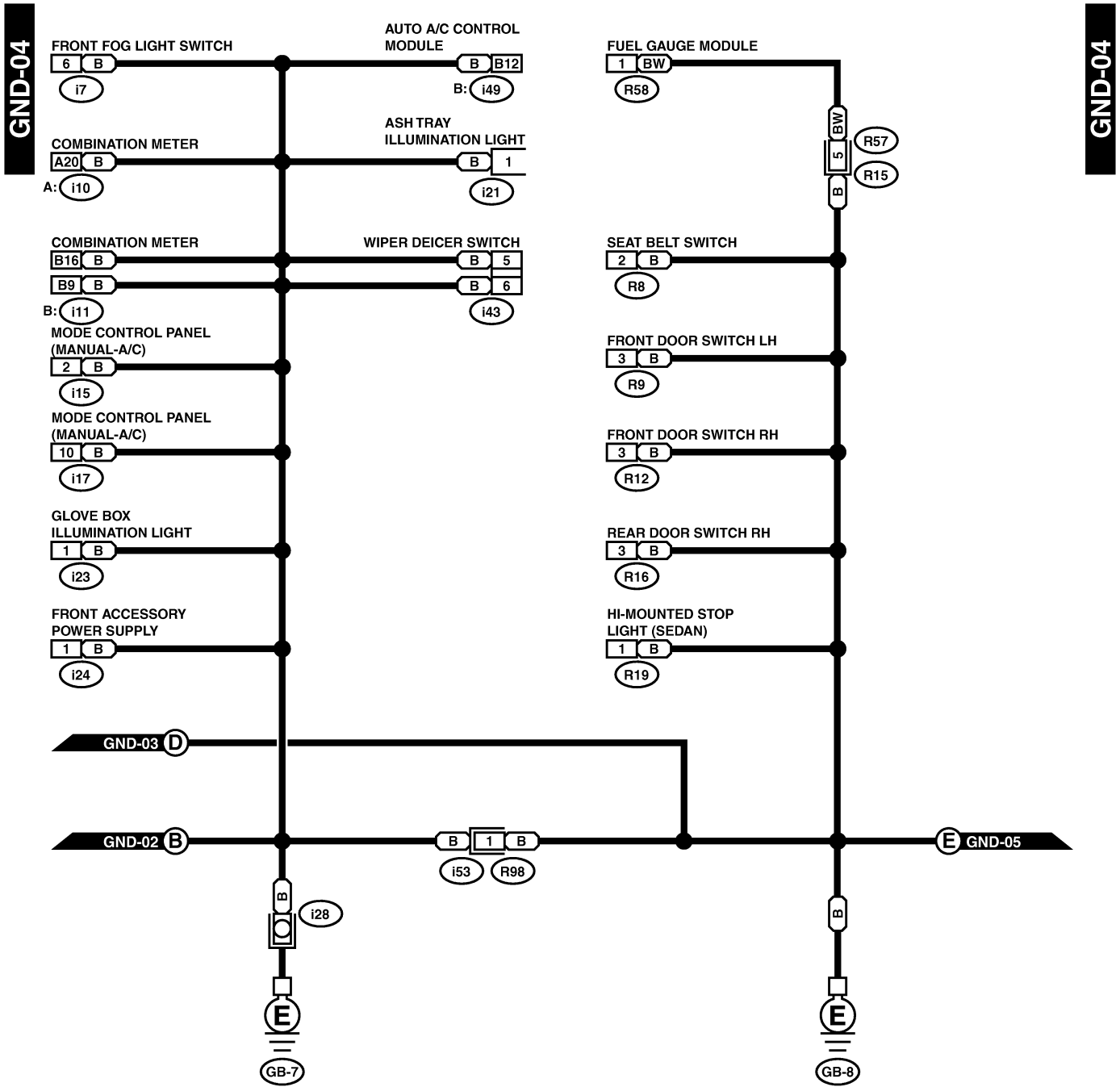

GROUND DISTRIBUTION

Wiring System

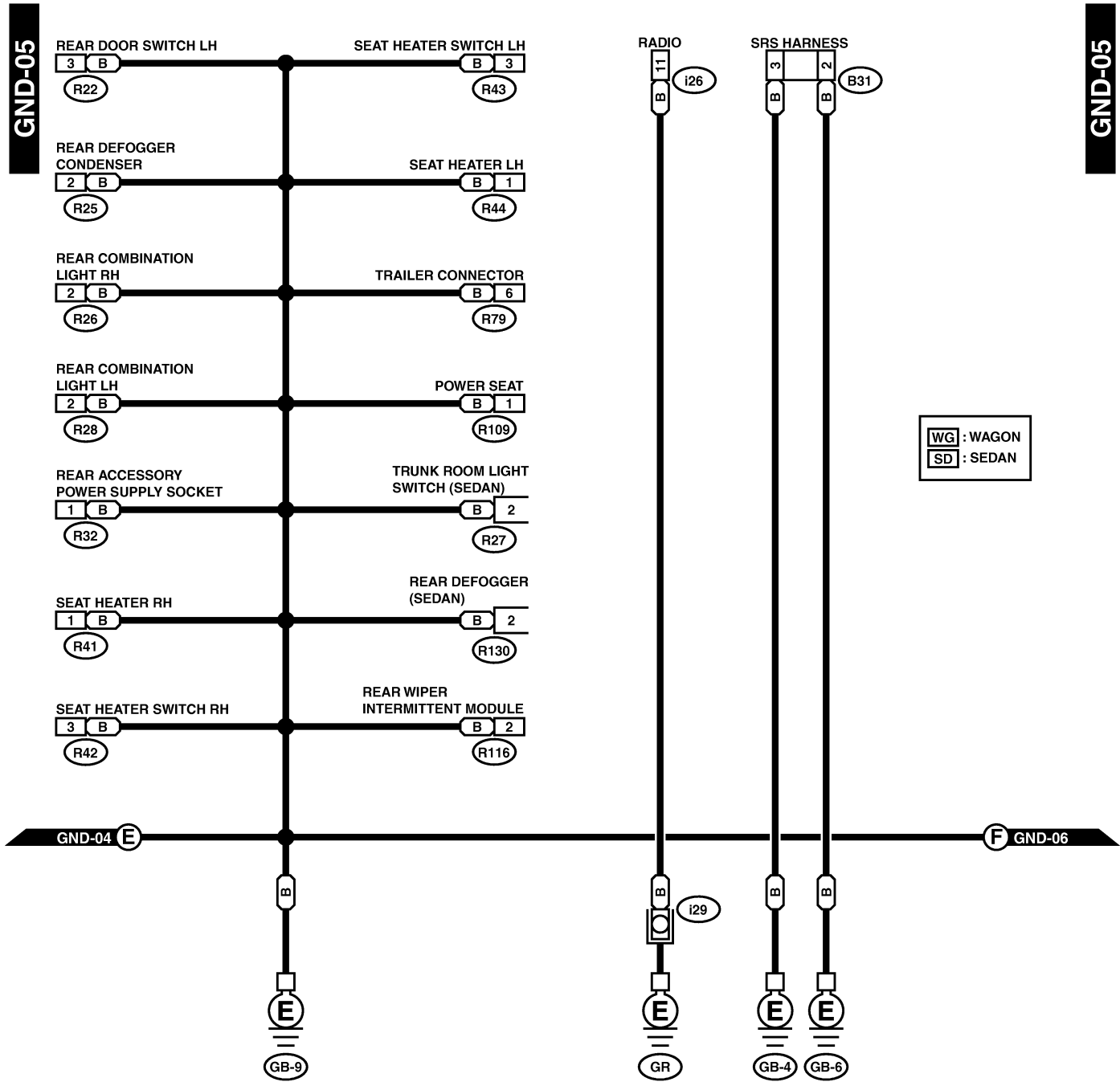

WG : WAGON
SD : SEDAN

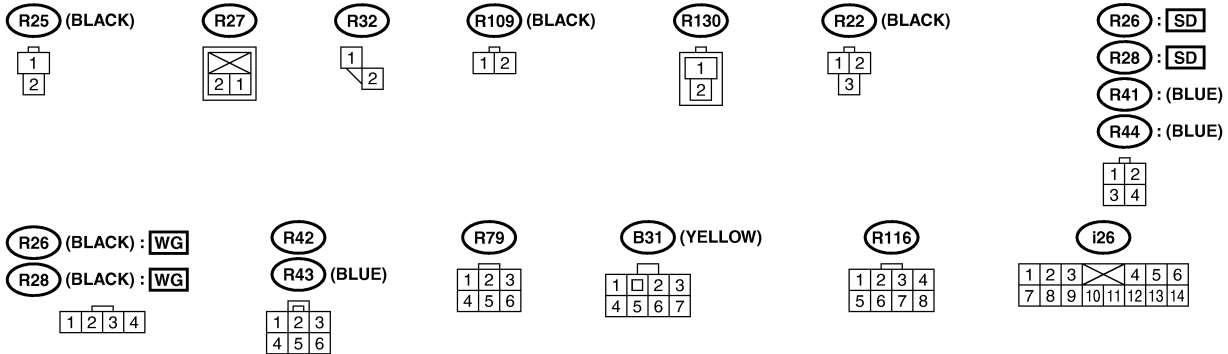

BG04-25E

GROUND DISTRIBUTION

Wiring System

GND-06

GND-06

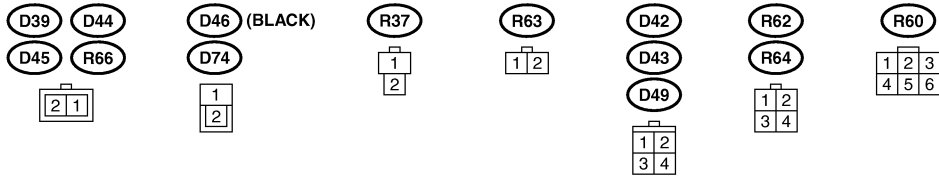
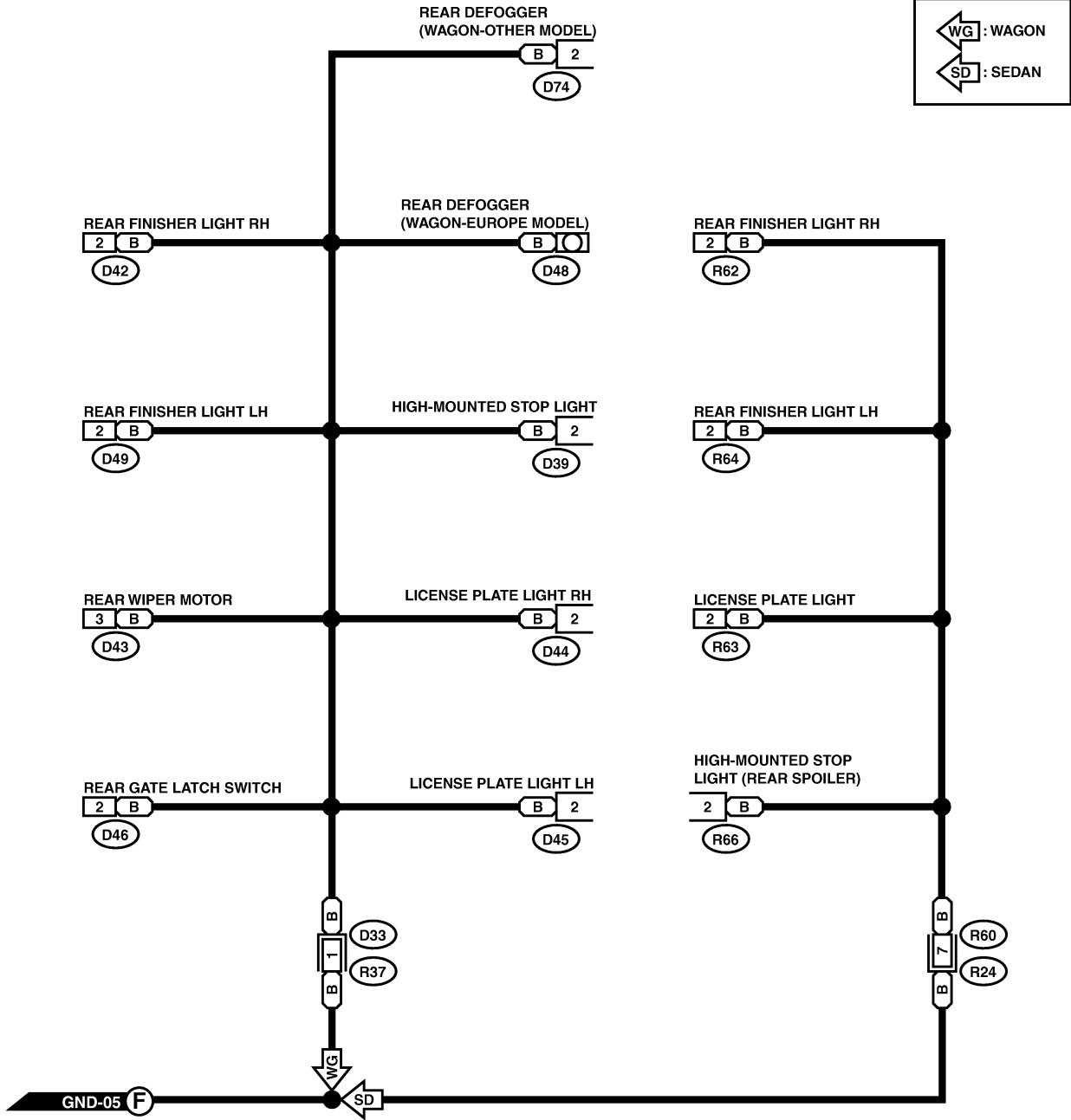

GROUND DISTRIBUTION

Wiring System

GND-07

GND-07

OV : WITHOUT VDC MODEL
WV : WITH VDC MODEL

A: B54 B: B55 C: B56 TRANSMISSION CONTROL MODULE

SHIELD JOINT CONNECTOR

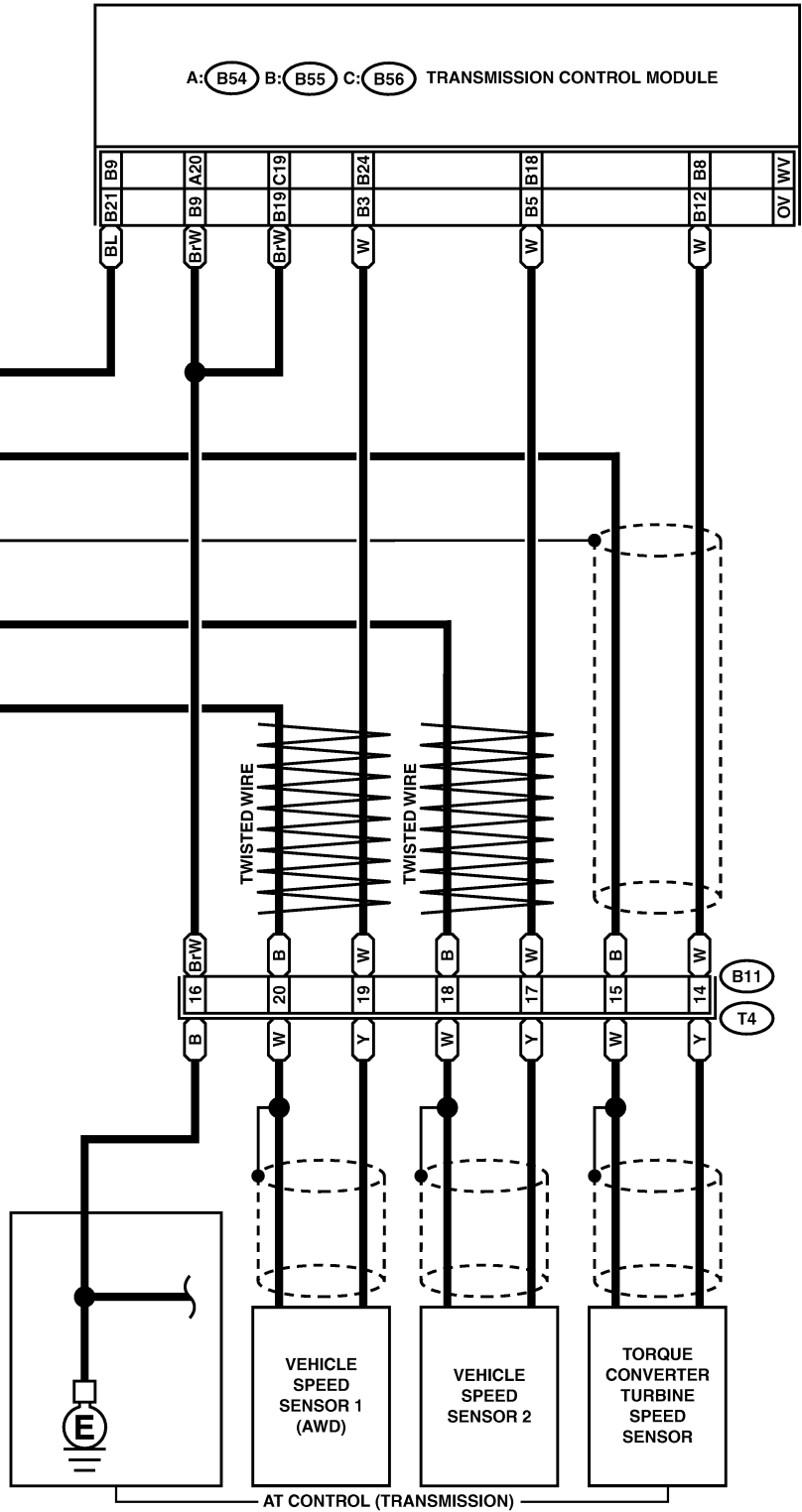
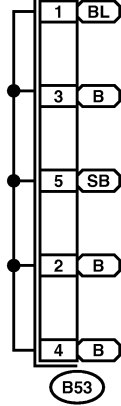

AT CONTROL (TRANSMISSION)

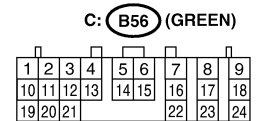
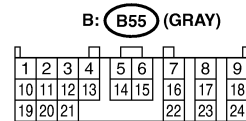
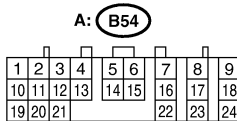
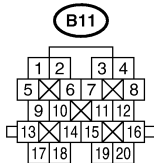
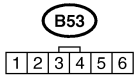

GROUND DISTRIBUTION

Wiring System

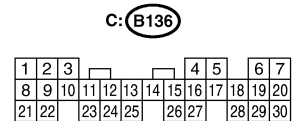
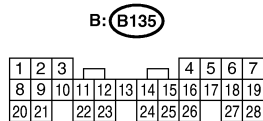
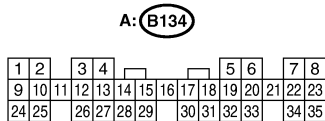
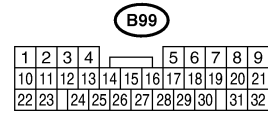
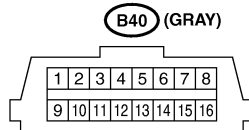
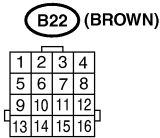
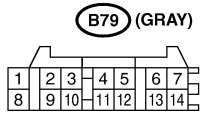
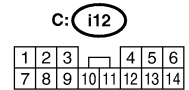
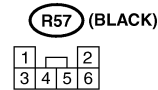
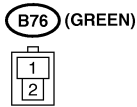
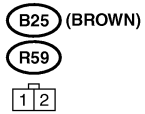
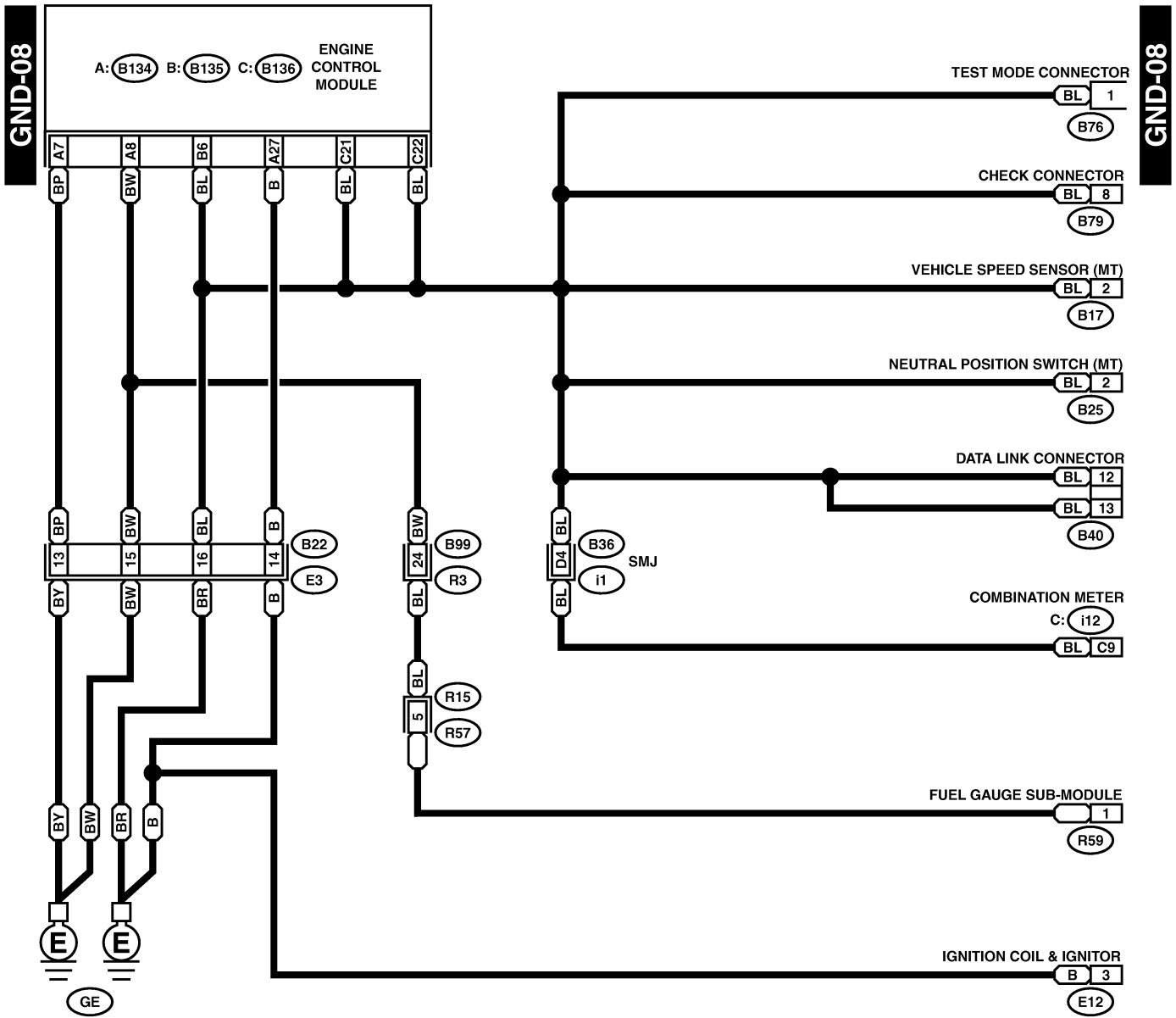

GROUND DISTRIBUTION

Wiring System

GND-09

GND-09

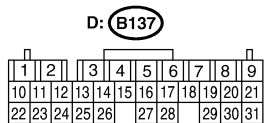
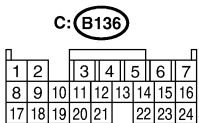
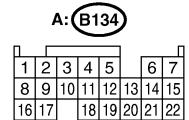
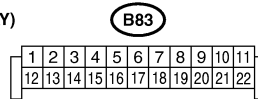
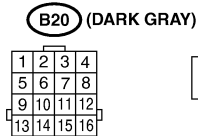
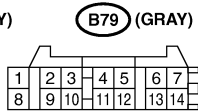
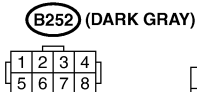
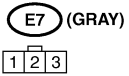
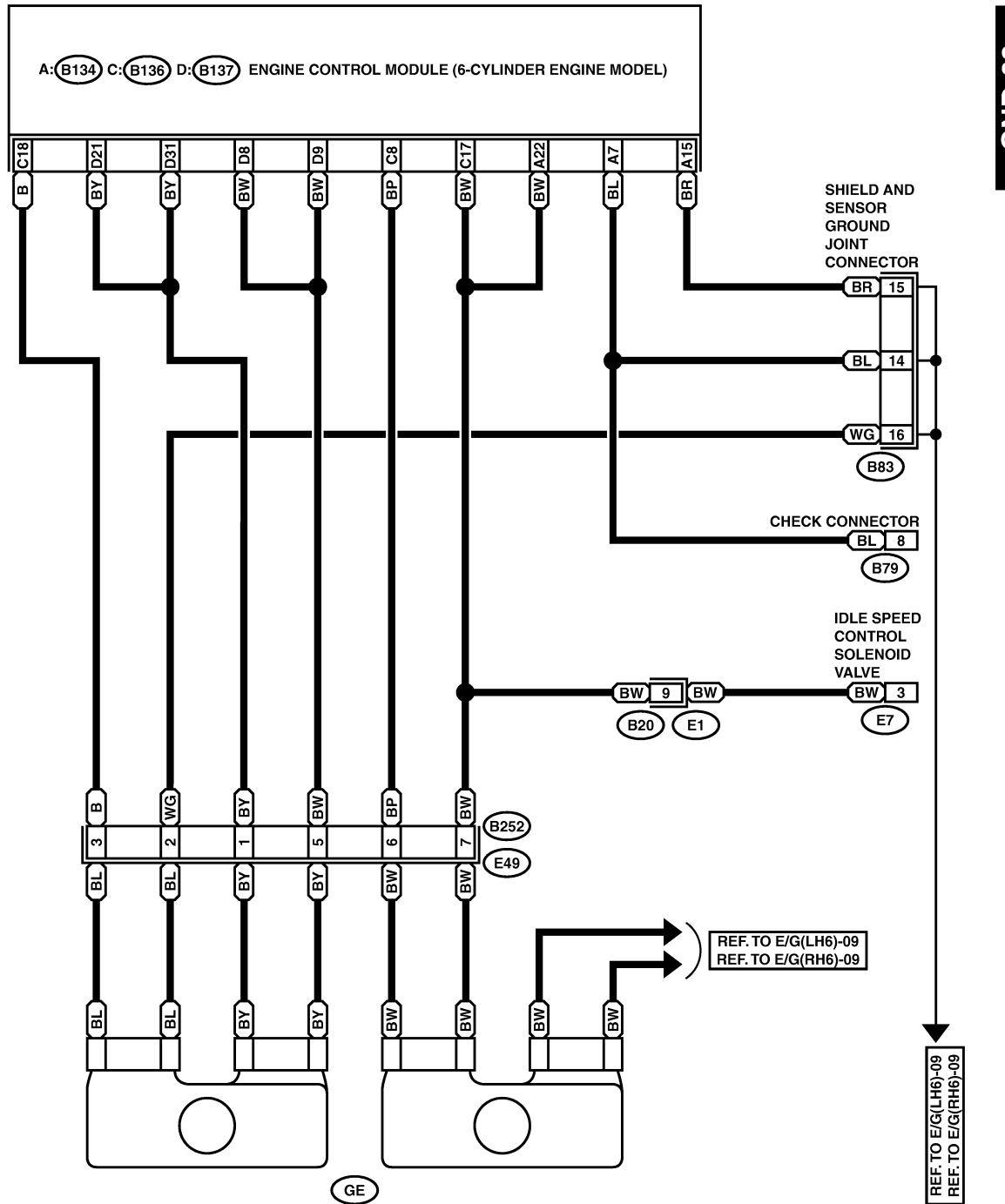

6. Airbag System S903491

A: SCHEMATIC S903491A21

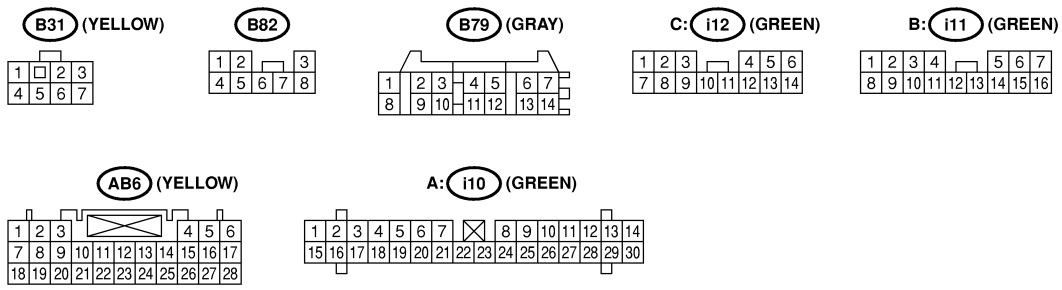
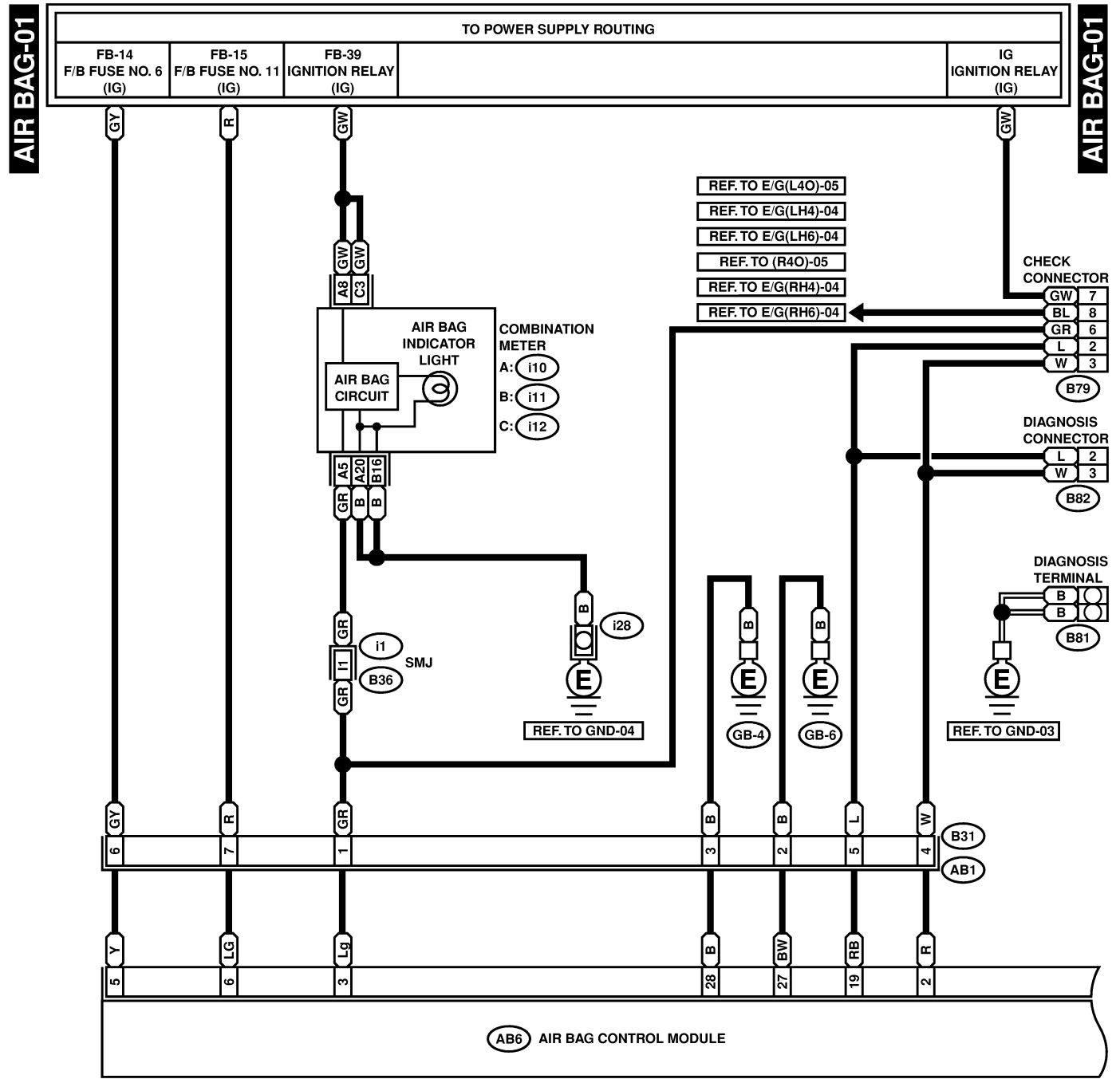

AIRBAG SYSTEM

Wiring System

AIR BAG-02

AIR BAG-02

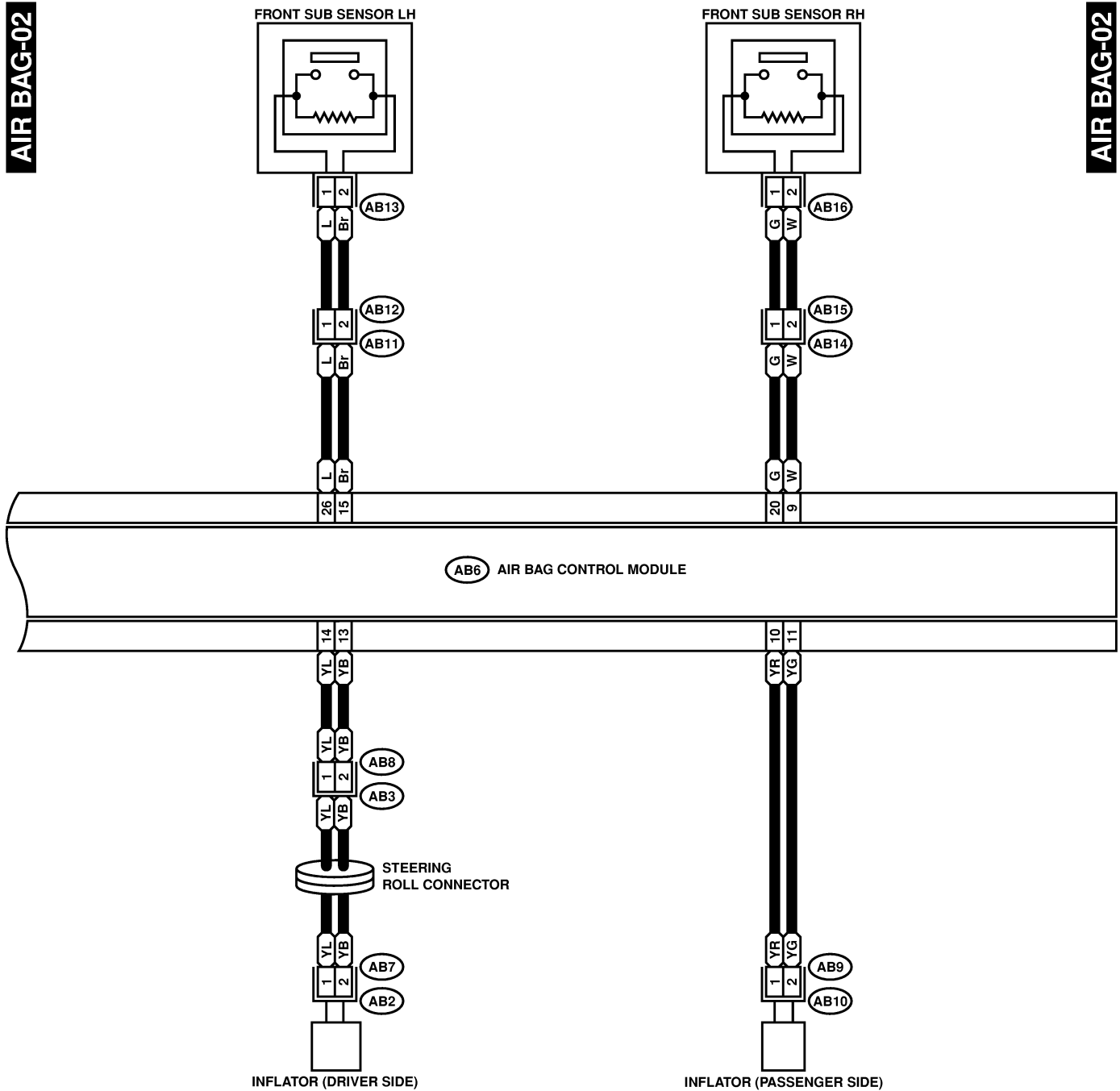

- AB7 (YELLOW)
- AB8 (YELLOW)
- AB13 (YELLOW)
- AB9 (YELLOW)
- AB12 (BLUE)
- AB16 (YELLOW)
- AB15 (BLUE)

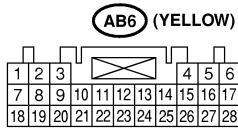
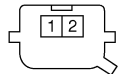

AIRBAG SYSTEM

Wiring System

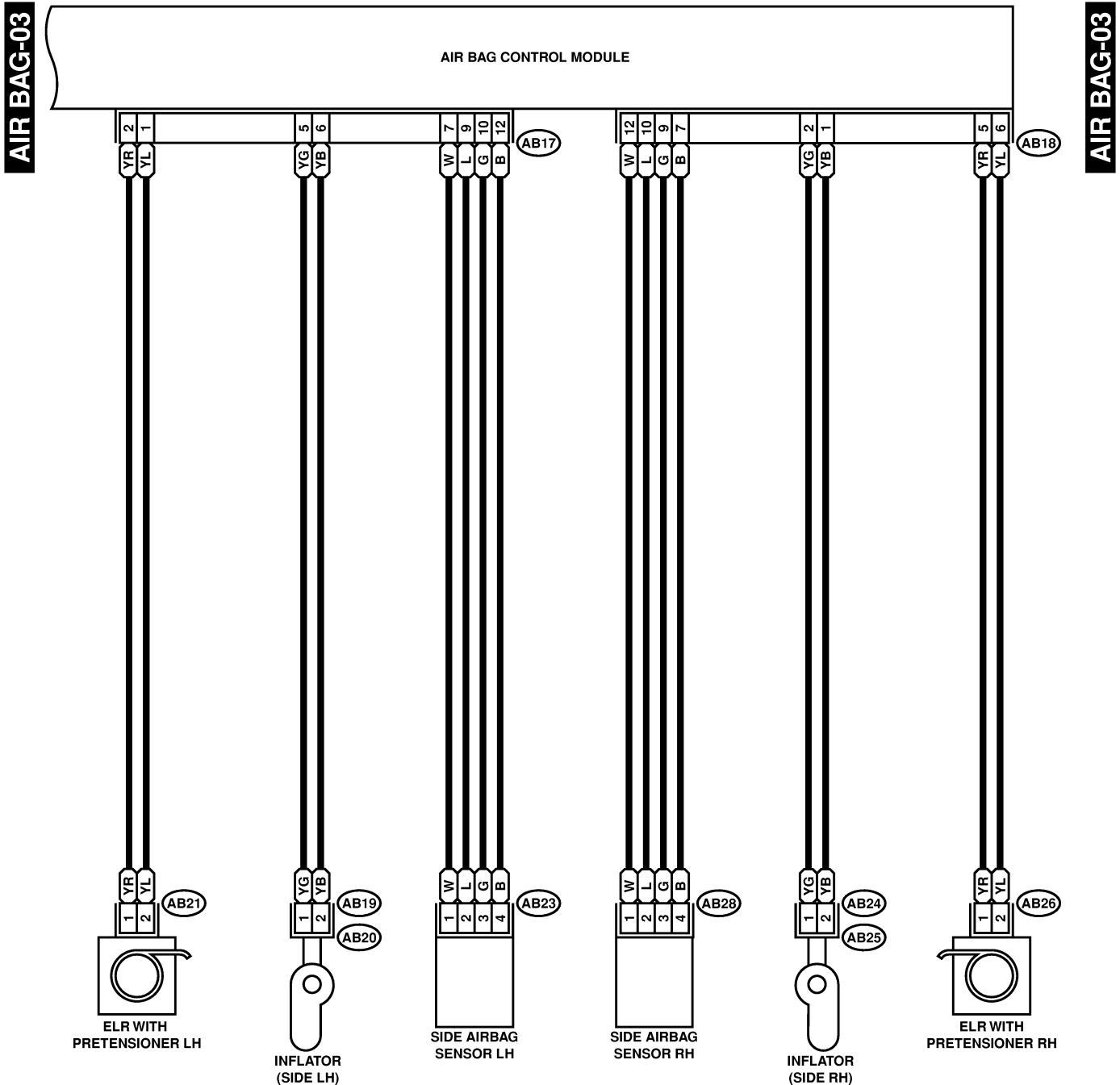

AB19 (YELLOW) AB21 (YELLOW)
 AB24 (YELLOW) AB26 (YELLOW)



AB23 (YELLOW) AB28 (YELLOW)

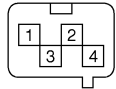

AB17 (YELLOW)

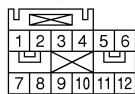

AB18 (YELLOW)

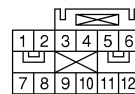

AIRBAG SYSTEM

Wiring System

MEMO: