

**SUPPLEMENT FOR 6 CYLINDER  
ENGINE MODEL**

This service manual has been prepared to provide SUBARU service personnel with the necessary information and data for the correct maintenance and repair of SUBARU vehicles.

This manual includes the procedures for maintenance, disassembling, reassembling, inspection and adjustment of components and diagnostics for guidance of experienced mechanics.

Please peruse and utilize this manual fully to ensure complete repair work for satisfying our customers by keeping their vehicle in optimum condition. When replacement of parts during repair work is needed, be sure to use SUBARU genuine parts.

All information, illustration and specifications contained in this manual are based on the latest product information available at the time of publication approval.

**FOREWORD****FW****HOW TO USE THIS MANUAL****HU****SPECIFICATIONS****SPC****PRECAUTION****PC****NOTE****NT****IDENTIFICATION****ID****RECOMMENDED MATERIALS****RM****PRE-DELIVERY INSPECTION****PI****PERIODICAL MAINTENANCE****PM**

**SUPPLEMENT FOR 6 CYLINDER  
ENGINE MODEL****FUEL INJECTION (FUEL SYSTEMS) FU(H6)****EMISSION CONTROL  
(AUX. EMISSION CONTROL DEVICES) EC(H6)****INTAKE (INDUCTION) IN(H6)****MECHANICAL ME(H6)****EXHAUST EX(H6)****COOLING CO(H6)****LUBRICATION LU(H6)****SPEED CONTROL SYSTEMS SP(H6)****IGNITION IG(H6)****START/CHARGING SYSTEMS SC(H6)****ENGINE (DIAGNOSTICS) EN(H6)****REAR SUSPENSION RS****WIRING SYSTEM WI**

# WIRING SYSTEM



---

	<b>Page</b>
1. Basic Diagnostics Procedure .....	3
2. Working Precautions .....	13
3. Super Multiple Junction (SMJ) .....	14
4. Power Supply Routing.....	17
5. Ground Distribution .....	32
6. Airbag System .....	41
7. Air Conditioning System.....	45
8. Anti-lock Brake System.....	66
9. A/T Control System .....	73
10. Audio System .....	95
11. Charging System.....	100
12. Combination Meter.....	101
13. Cruise Control System .....	107
14. Door Lock System.....	120
15. Engine Coolant Temperature Gauge System .....	124
16. Engine Electrical System .....	125
17. Fuel Gauge System .....	181
18. Full-Time Dual-Range System .....	184
19. Front Accessory Power Supply System.....	185
20. Headlight Beam Leveler System.....	186
21. Horn System.....	187
22. Immobilizer System .....	188
23. Keyless Entry System .....	192
24. Back-up Light System .....	198
25. Clearance Light and Illumination Light System .....	199
26. Front Fog Light System.....	206
27. Headlight System .....	209
28. In Compartment Light System.....	211
29. Stop Light System .....	217
30. Turn Signal Light and Hazard Light System.....	219
31. Oil Pressure Warning Light System.....	223
32. Outside Temperature Display System.....	224
33. Parking Brake and Brake Fluid Level Warning System.....	225
34. Pneumatic (Air) Suspension System .....	226
35. Power Seat System.....	234
36. Power Window System .....	235
37. Radiator Fan System .....	244
38. Rear Accessory Power Supply System .....	247
39. Rear Fog Light System .....	248
40. Rear Window Defogger System.....	249
41. Remote Controlled Rearview Mirror System .....	250
42. Seat Belt Warning System .....	252
43. Seat Heater System.....	254
44. Starter System.....	255

# GENERAL DIAGNOSTIC TABLE

45.	Sunroof System.....	256
46.	Vehicle Dynamic Control System.....	257
47.	Wiper and Washer System (Front) .....	273
48.	Wiper and Washer System (Rear).....	275
49.	Wiper Deicer System .....	277
50.	Overall Systems .....	278
51.	Front Wiring Harness .....	282
52.	Bulkhead Wiring Harness (In Engine Room).....	288
53.	Bulkhead Wiring Harness (In Compartment).....	296
54.	Engine Wiring Harness and Transmission Cord.....	305
55.	Instrument Panel Wiring Harness .....	309
56.	Rear Wiring Harness.....	313
57.	Door Cord.....	321
58.	Rear Wiring Harness and Trunk Lid Cord .....	325
59.	Rear Wiring Harness and Rear Gate Cord.....	327

# SUNROOF SYSTEM

Wiring System

## 45. Sunroof System S903440

### A: SCHEMATIC S903440A21

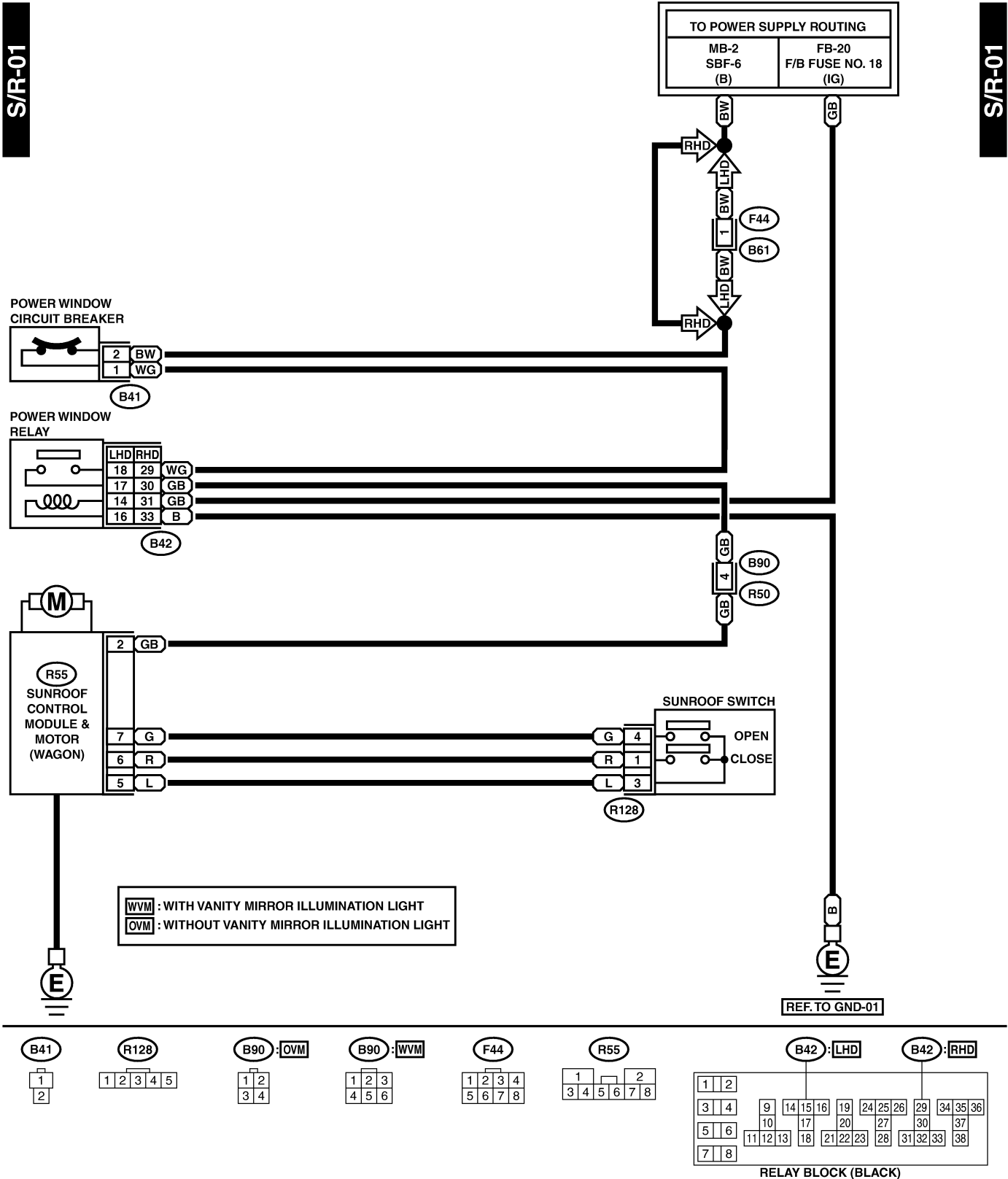

## 46. Vehicle Dynamic Control System S903441

### A: SCHEMATIC S903441A21

#### 1. LHD-H4 MODEL S903441A2103

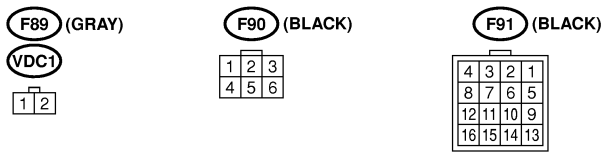
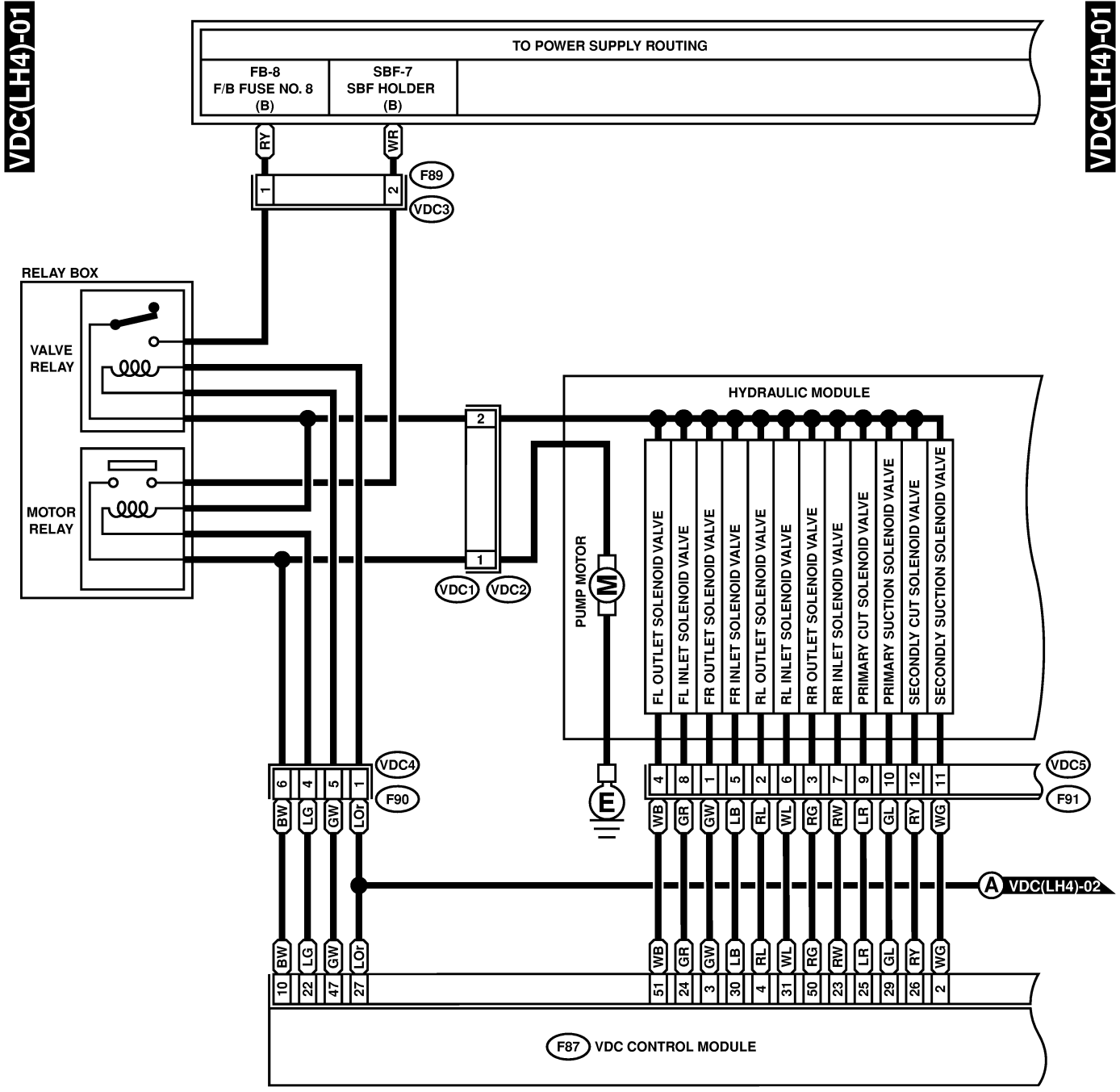

F87 (BLACK)

1	2	3	4	5	6	7	8	9	10	11	12	13	14	15	16	17	18	19	20	21	22	23	24	25	26	27	28	
29	30	31	32	33	34	35	36	37	38	39	40	41	42	43	44	45	46	47	48	49	50	51	52	53	54	55	56	57
58	59	60	61	62	63	64	65	66	67	68	69	70	71	72	73	74	75	76	77	78	79	80	81	82	83			

# VEHICLE DYNAMIC CONTROL SYSTEM

Wiring System

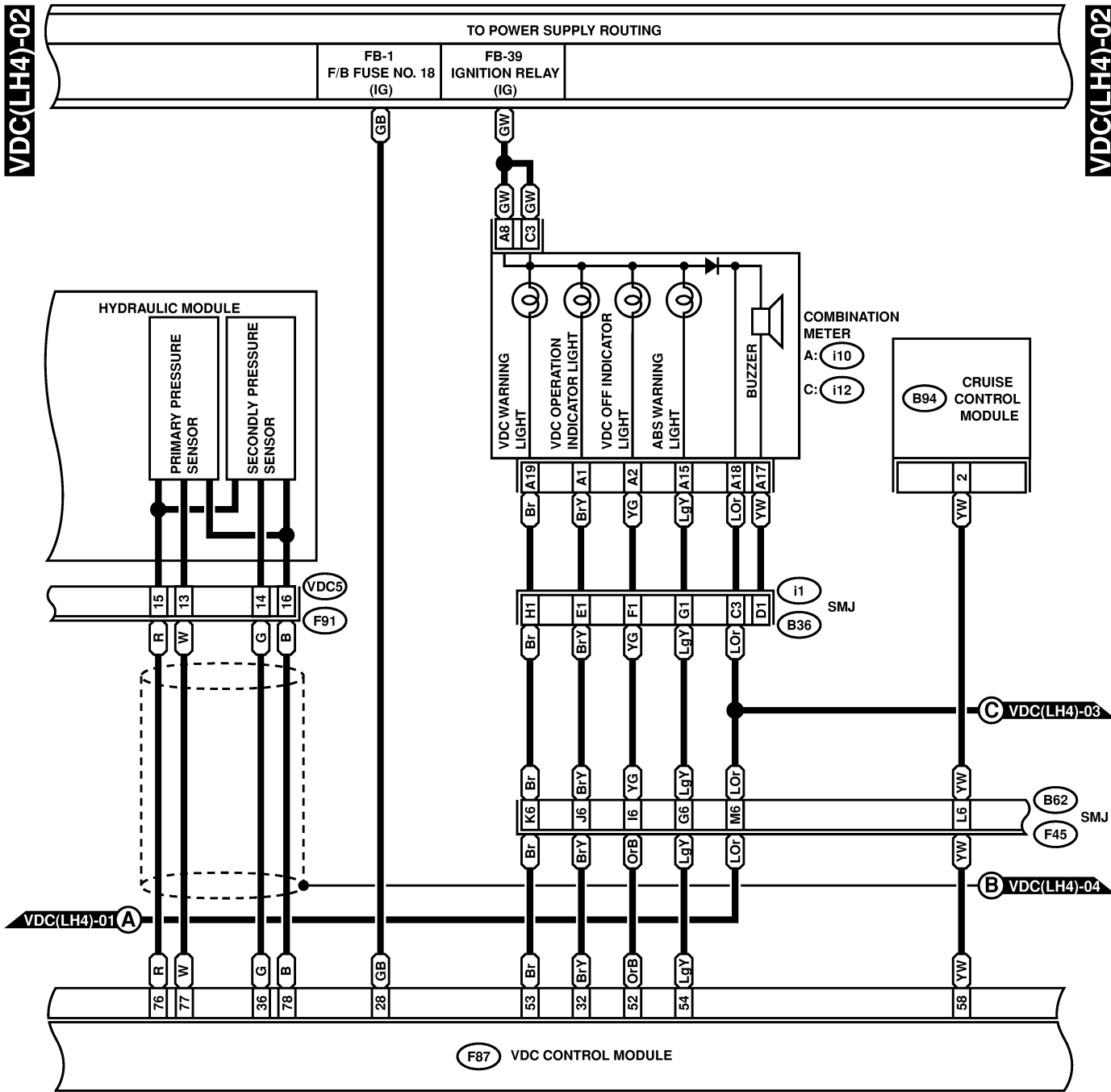

C: i12 (GREEN)

1	2	3	4	5	6
7	8	9	10	11	12
13	14				

F91 (BLACK)

4	3	2	1
8	7	6	5
12	11	10	9
16	15	14	13

B94 (BLACK)

1	2	3	4	5	6	7	8	9	10
11	12	13	14	15	16	17	18	19	20

A: i10 (GREEN)

1	2	3	4	5	6	7	8	9	10	11	12	13	14
15	16	17	18	19	20	21	22	23	24	25	26	27	28
29	30												

F87 (BLACK)

1	2	3	4	5	6	7	8	9	10	11	12	13	14	15	16	17	18	19	20	21	22	23	24	25	26	27	28
29	30	31	32	33	34	35	36	37	38	39	40	41	42	43	44	45	46	47	48	49	50	51	52	53	54	55	56
57	58	59	60	61	62	63	64	65	66	67	68	69	70	71	72	73	74	75	76	77	78	79	80	81	82	83	84

# VEHICLE DYNAMIC CONTROL SYSTEM

Wiring System

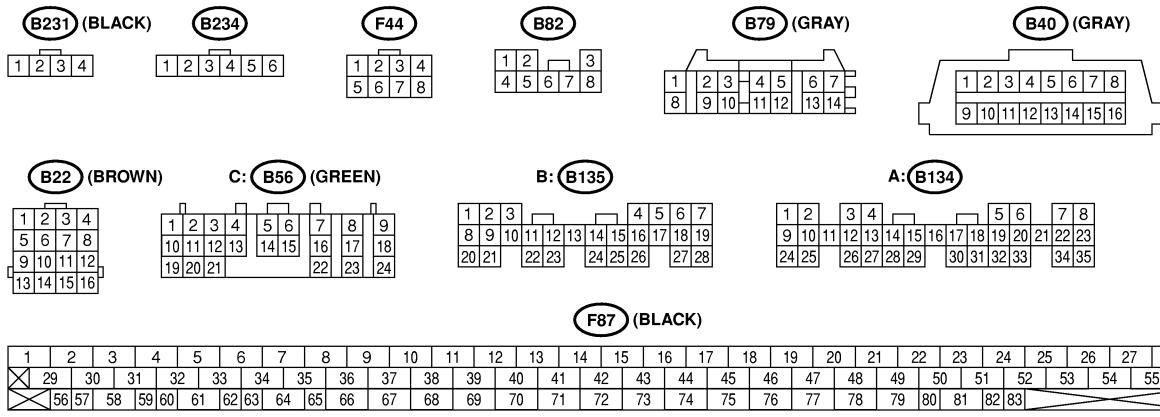
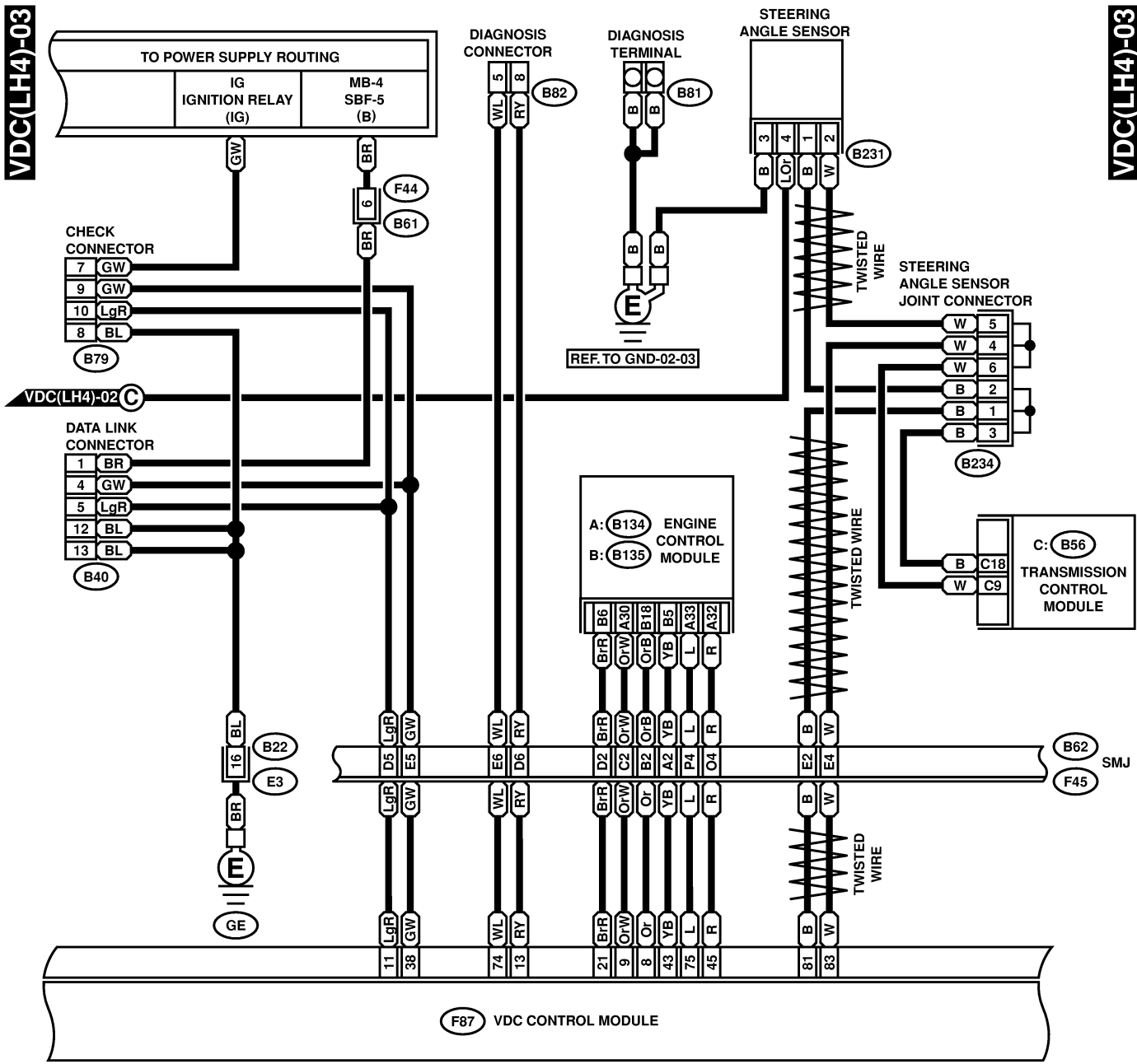





# VEHICLE DYNAMIC CONTROL SYSTEM

Wiring System

## 2. LHD-H6 MODEL S903441A2104

VDC(LH6)-01

VDC(LH6)-01

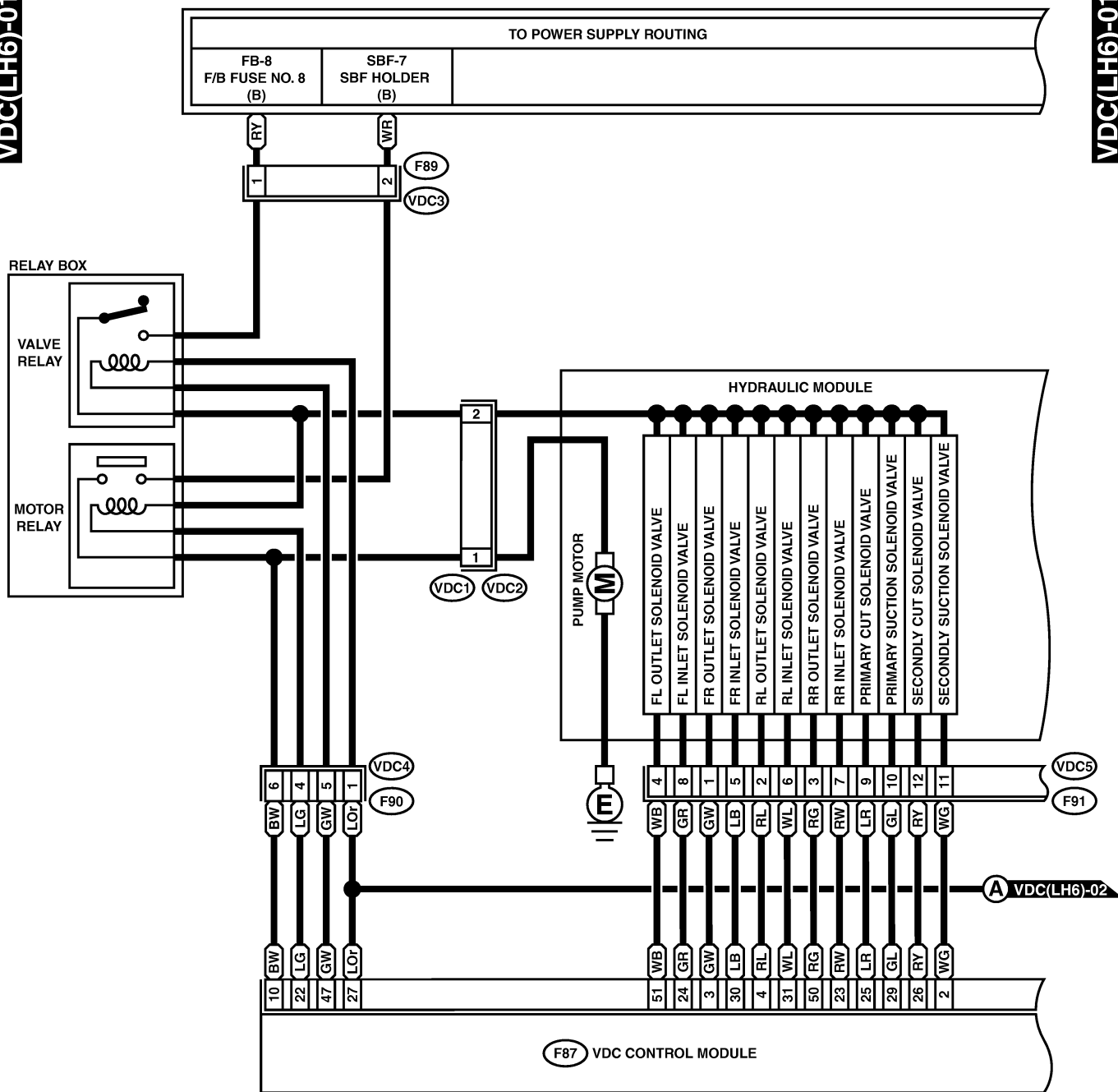

F89 (GRAY)

F90 (BLACK)

F91 (BLACK)

VDC1

1	2	3
4	5	6

4	3	2	1
8	7	6	5
12	11	10	9
16	15	14	13

F87 (BLACK)

1	2	3	4	5	6	7	8	9	10	11	12	13	14	15	16	17	18	19	20	21	22	23	24	25	26	27	28	
29	30	31	32	33	34	35	36	37	38	39	40	41	42	43	44	45	46	47	48	49	50	51	52	53	54	55		
56	57	58	59	60	61	62	63	64	65	66	67	68	69	70	71	72	73	74	75	76	77	78	79	80	81	82	83	



# VEHICLE DYNAMIC CONTROL SYSTEM

Wiring System

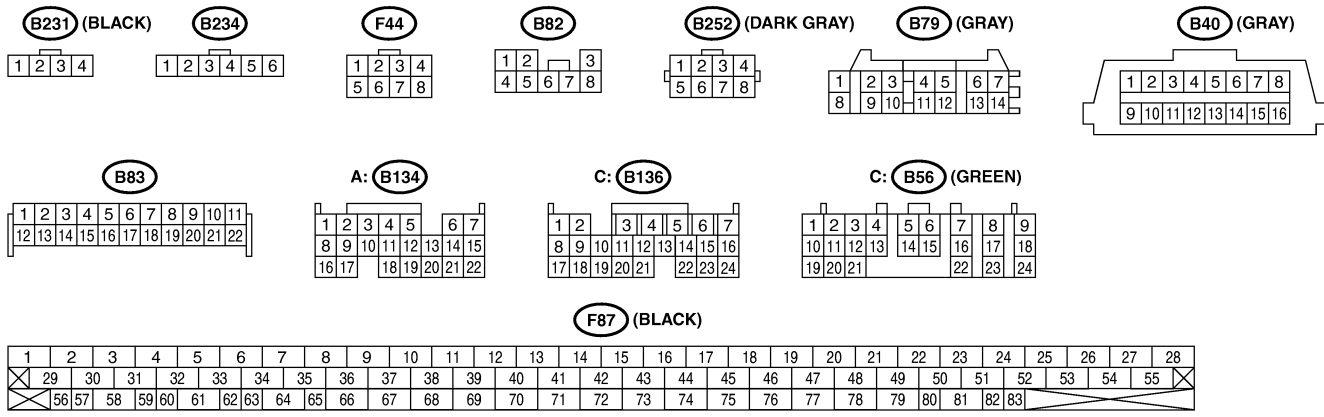
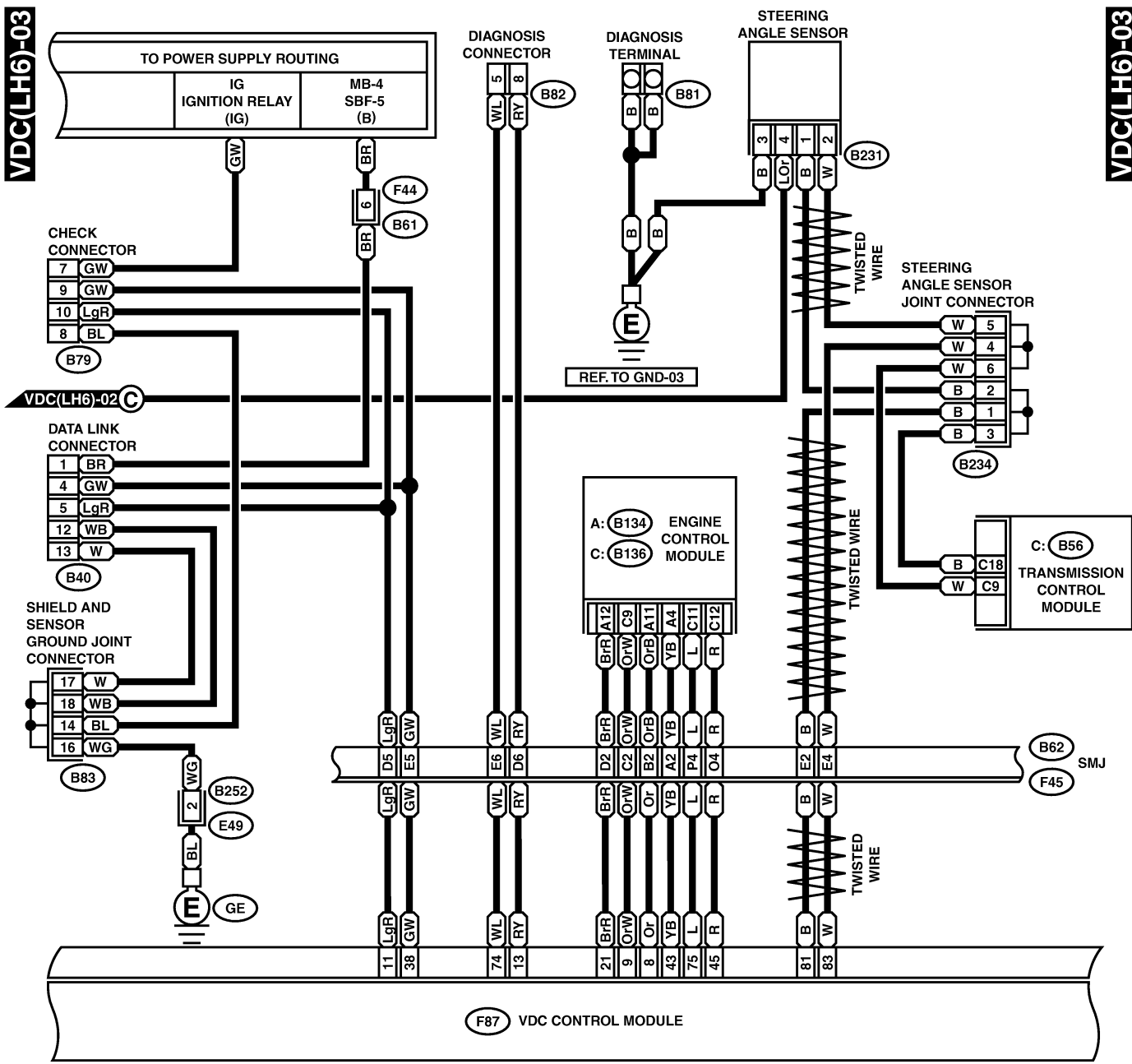

# VEHICLE DYNAMIC CONTROL SYSTEM

Wiring System

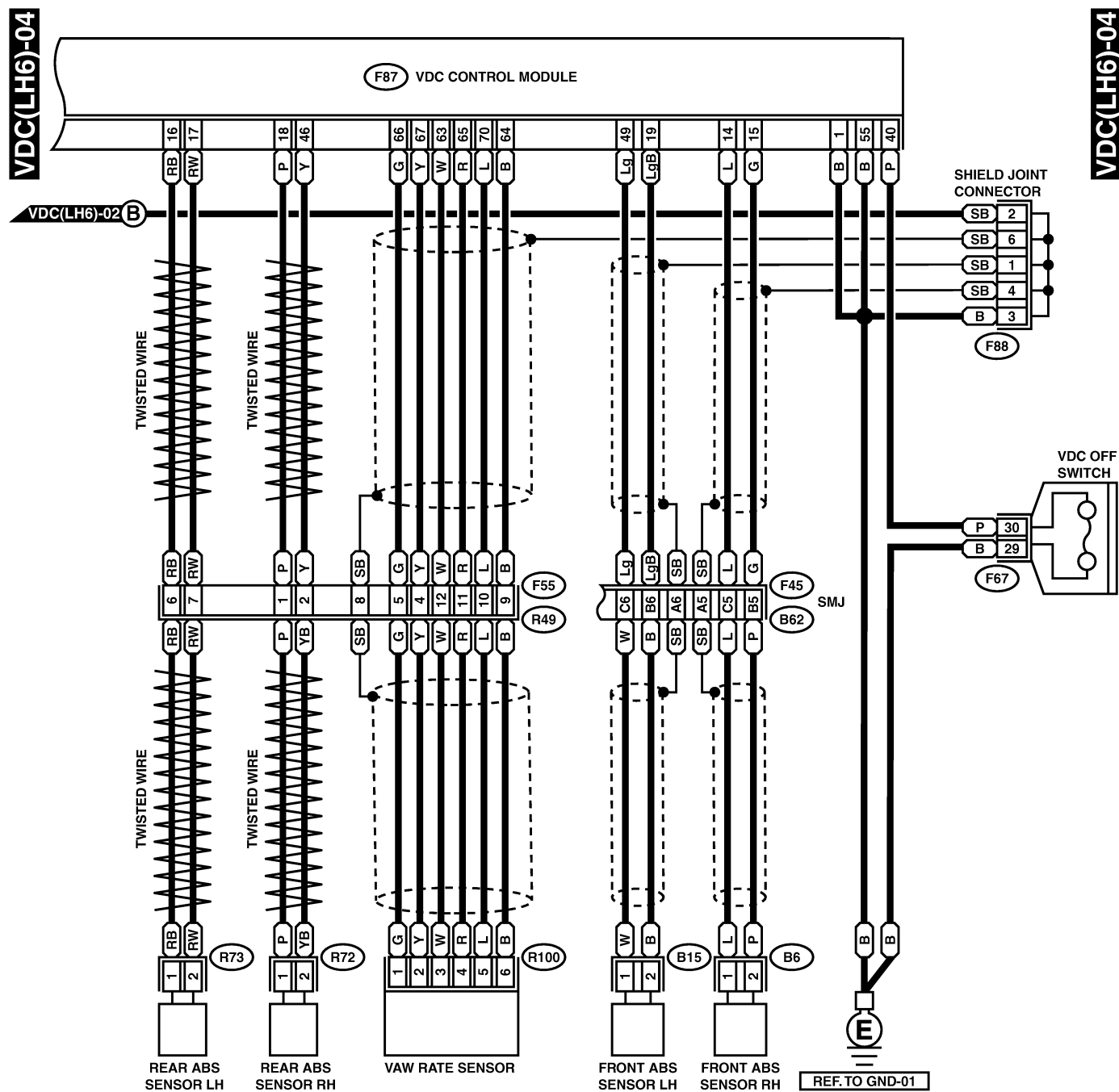

**B6 (GRAY)**  
**B15 (GRAY)**  
**R73 (GRAY)**  
**R72 (GRAY)**

**R100**

**F88**

**F55**

**F67**

**F87 (BLACK)**

**RELAY HOLDER (BLACK)**

1	2	3	4	5	6	7	8	9	10	11	12	13	14	15	16	17	18	19	20	21	22	23	24	25	26	27	28	
⊗	29	30	31	32	33	34	35	36	37	38	39	40	41	42	43	44	45	46	47	48	49	50	51	52	53	54	55	⊗
⊗	56	57	58	59	60	61	62	63	64	65	66	67	68	69	70	71	72	73	74	75	76	77	78	79	80	81	82	83

# VEHICLE DYNAMIC CONTROL SYSTEM

Wiring System

## 3. RHD-H4 MODEL S903441A2105

VDC(RH4)-01

VDC(RH4)-01

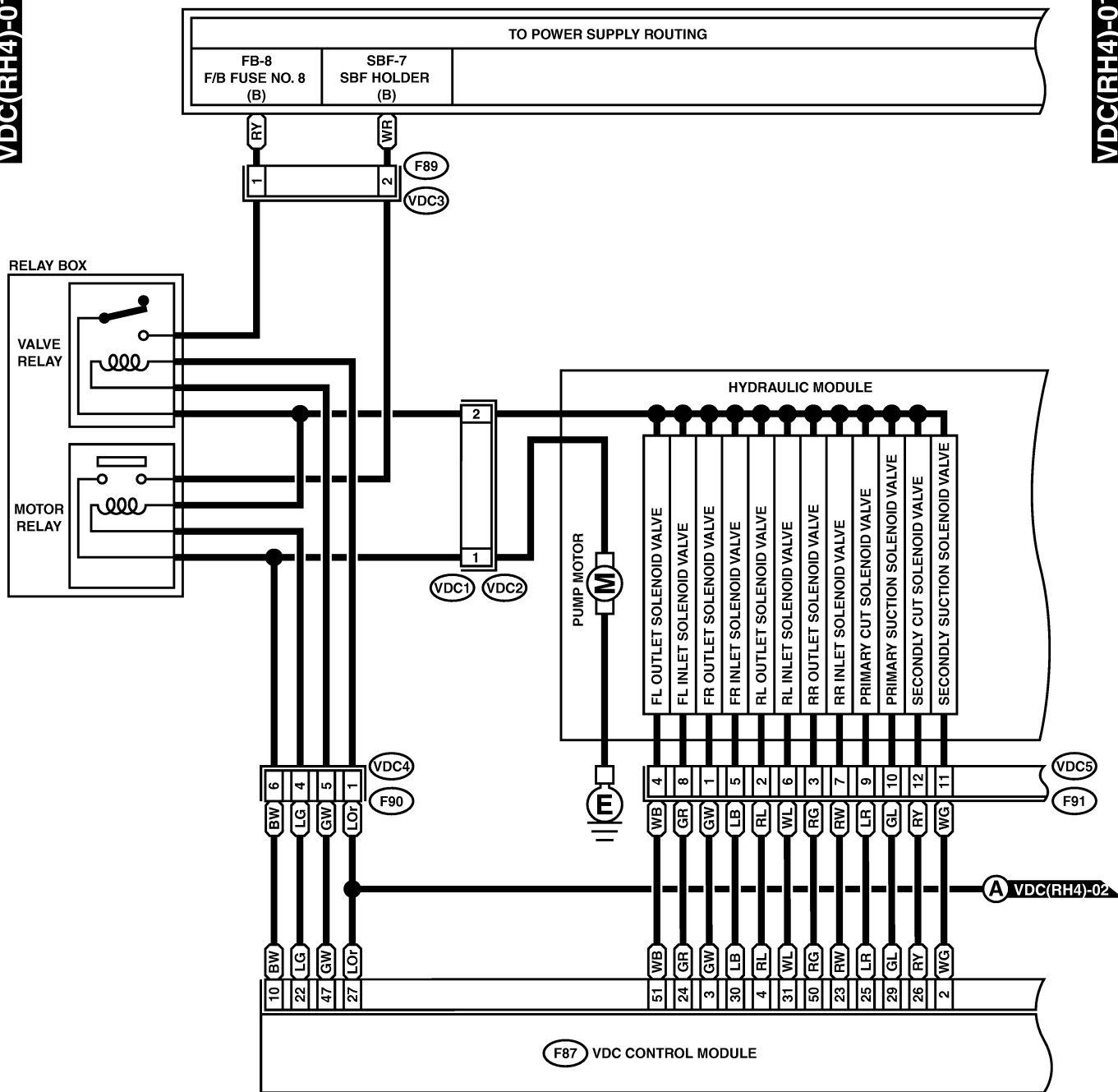

F89 (GRAY)

F90 (BLACK)

F91 (BLACK)

VDC1

1	2	3
4	5	6

4	3	2	1
8	7	6	5
12	11	10	9
16	15	14	13

F87 (BLACK)

1	2	3	4	5	6	7	8	9	10	11	12	13	14	15	16	17	18	19	20	21	22	23	24	25	26	27	28	
29	30	31	32	33	34	35	36	37	38	39	40	41	42	43	44	45	46	47	48	49	50	51	52	53	54	55		
56	57	58	59	60	61	62	63	64	65	66	67	68	69	70	71	72	73	74	75	76	77	78	79	80	81	82	83	

# VEHICLE DYNAMIC CONTROL SYSTEM

Wiring System

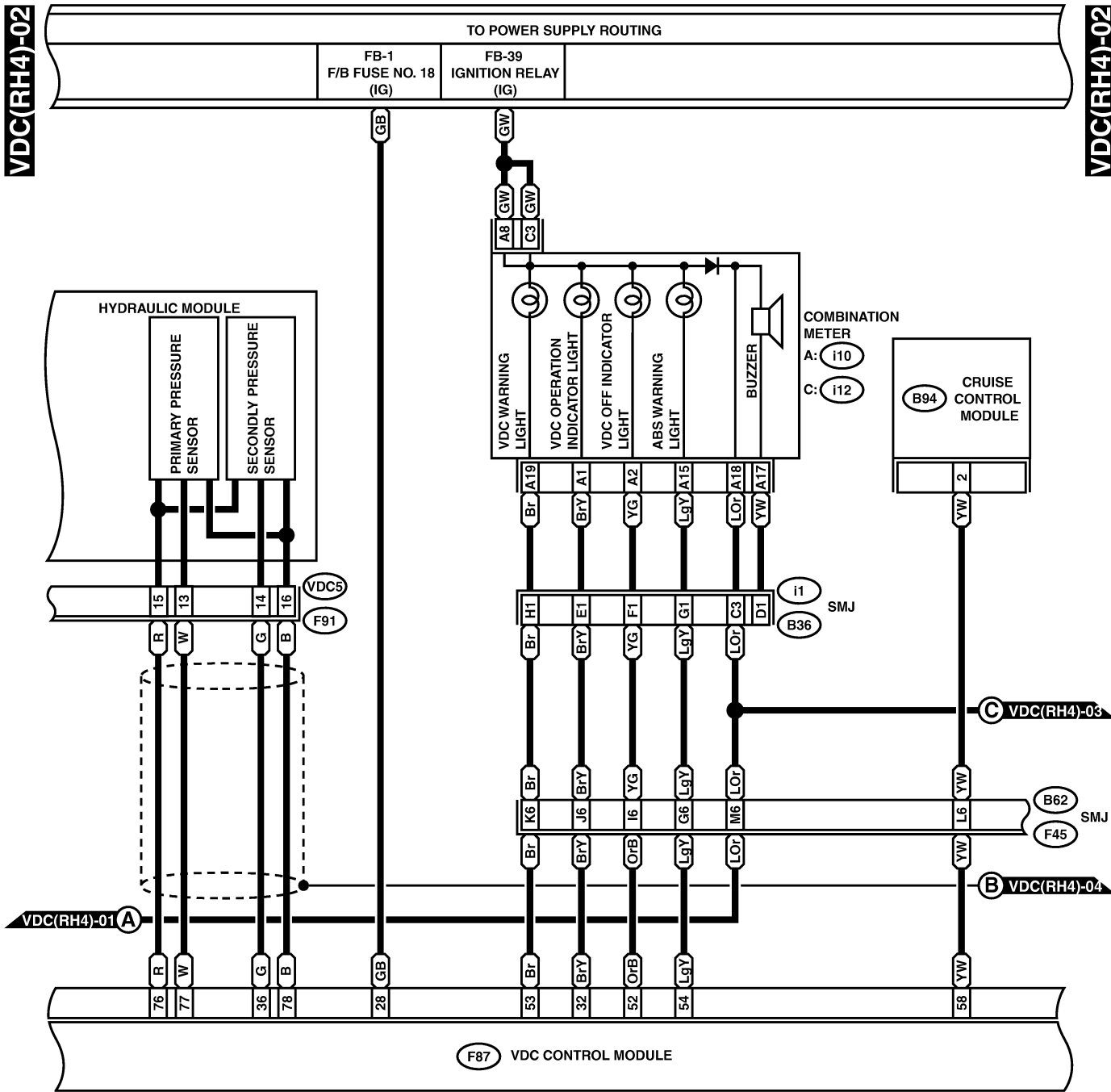

C: i12 (GREEN)

1	2	3	4	5	6
7	8	9	10	11	12
13	14				

F91 (BLACK)

4	3	2	1
8	7	6	5
12	11	10	9
16	15	14	13

B94 (BLACK)

1	2	3	4	5	6	7	8	9	10
11	12	13	14	15	16	17	18	19	20

A: i10 (GREEN)

1	2	3	4	5	6	7	8	9	10	11	12	13	14
15	16	17	18	19	20	21	22	23	24	25	26	27	28
29	30												

F87 (BLACK)

1	2	3	4	5	6	7	8	9	10	11	12	13	14	15	16	17	18	19	20	21	22	23	24	25	26	27	28
29	30	31	32	33	34	35	36	37	38	39	40	41	42	43	44	45	46	47	48	49	50	51	52	53	54	55	56
57	58	59	60	61	62	63	64	65	66	67	68	69	70	71	72	73	74	75	76	77	78	79	80	81	82	83	84

# VEHICLE DYNAMIC CONTROL SYSTEM

Wiring System

VDC(RH4)-03

VDC(RH4)-03

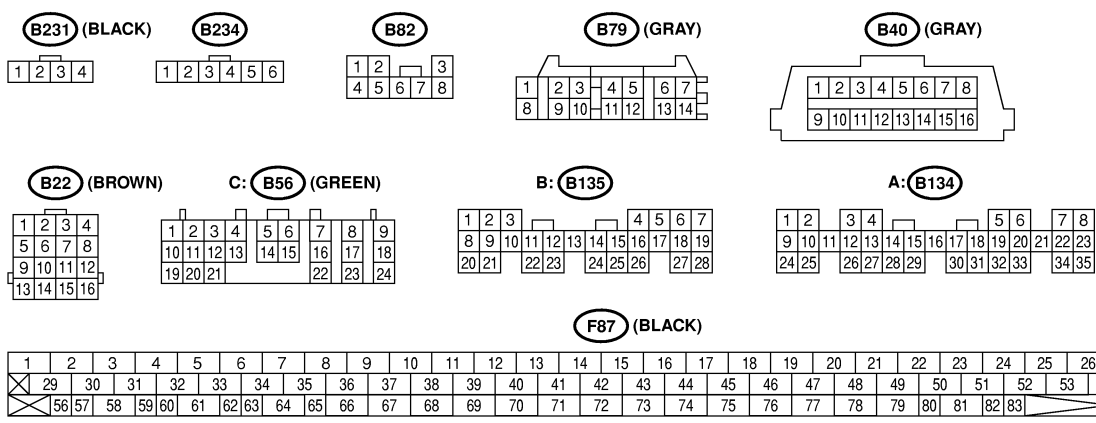
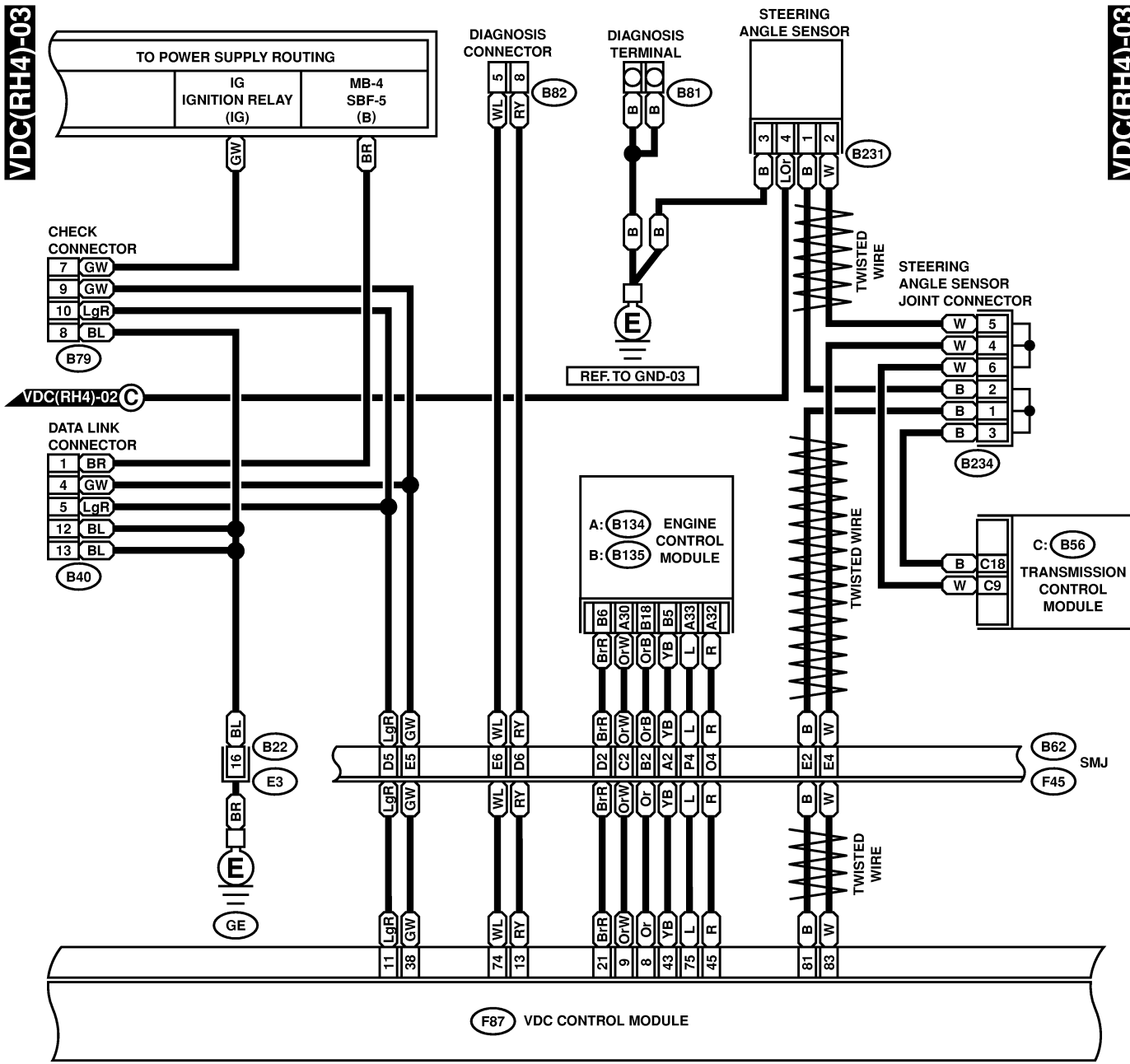

1	2	3	4	5	6	7	8	9	10	11	12	13	14	15	16	17	18	19	20	21	22	23	24	25	26	27	28
29	30	31	32	33	34	35	36	37	38	39	40	41	42	43	44	45	46	47	48	49	50	51	52	53	54	55	
56	57	58	59	60	61	62	63	64	65	66	67	68	69	70	71	72	73	74	75	76	77	78	79	80	81	82	83



# VEHICLE DYNAMIC CONTROL SYSTEM

Wiring System

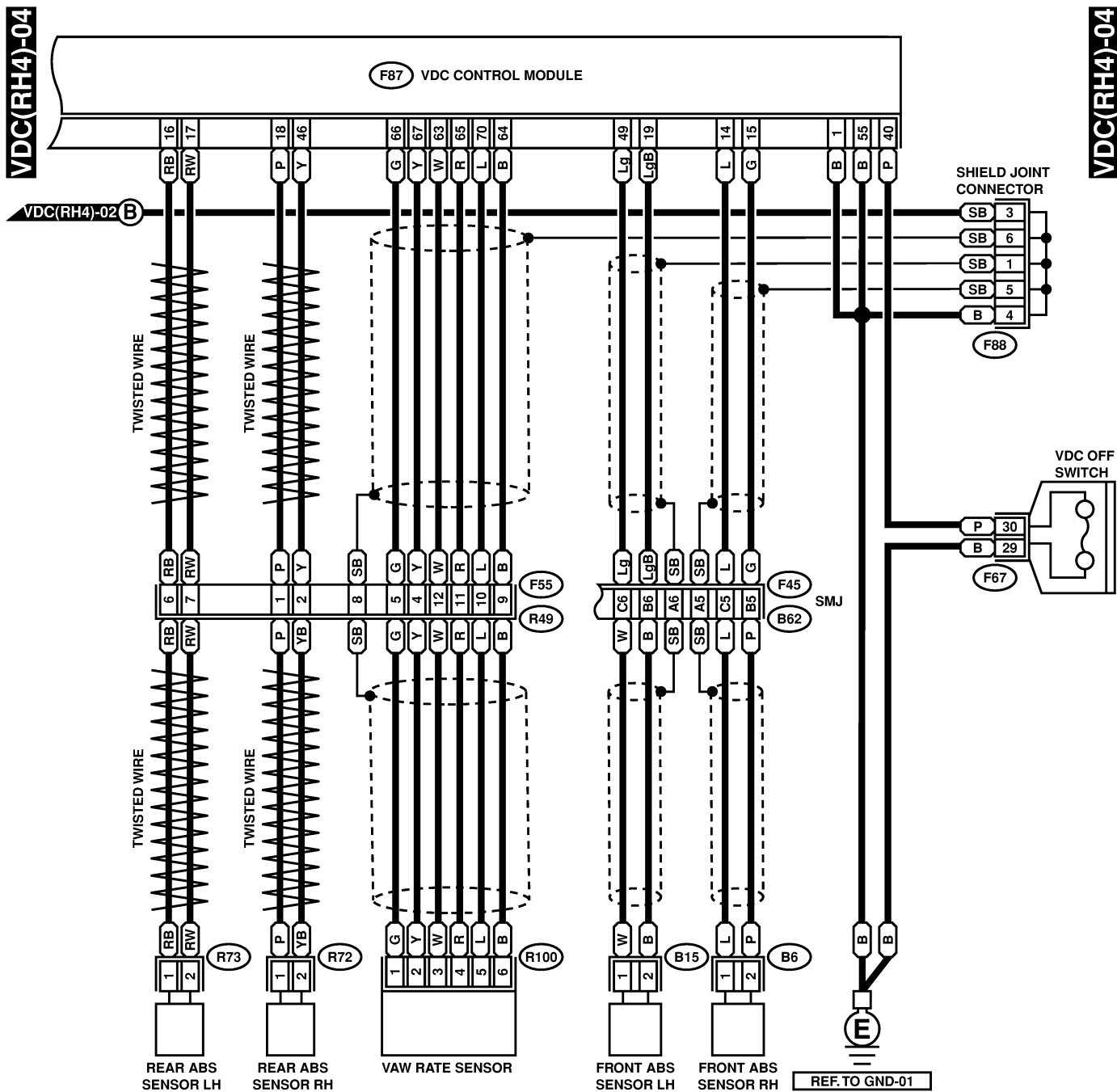

- B6** (GRAY)
- B15** (GRAY)
- R73** (GRAY)
- R72** (GRAY)

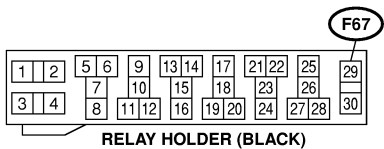
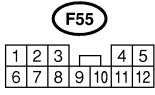
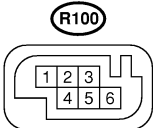

**F87** (BLACK)

1	2	3	4	5	6	7	8	9	10	11	12	13	14	15	16	17	18	19	20	21	22	23	24	25	26	27	28
29	30	31	32	33	34	35	36	37	38	39	40	41	42	43	44	45	46	47	48	49	50	51	52	53	54	55	56
57	58	59	60	61	62	63	64	65	66	67	68	69	70	71	72	73	74	75	76	77	78	79	80	81	82	83	84

## 4. RHD-H6 MODEL S903441A2106

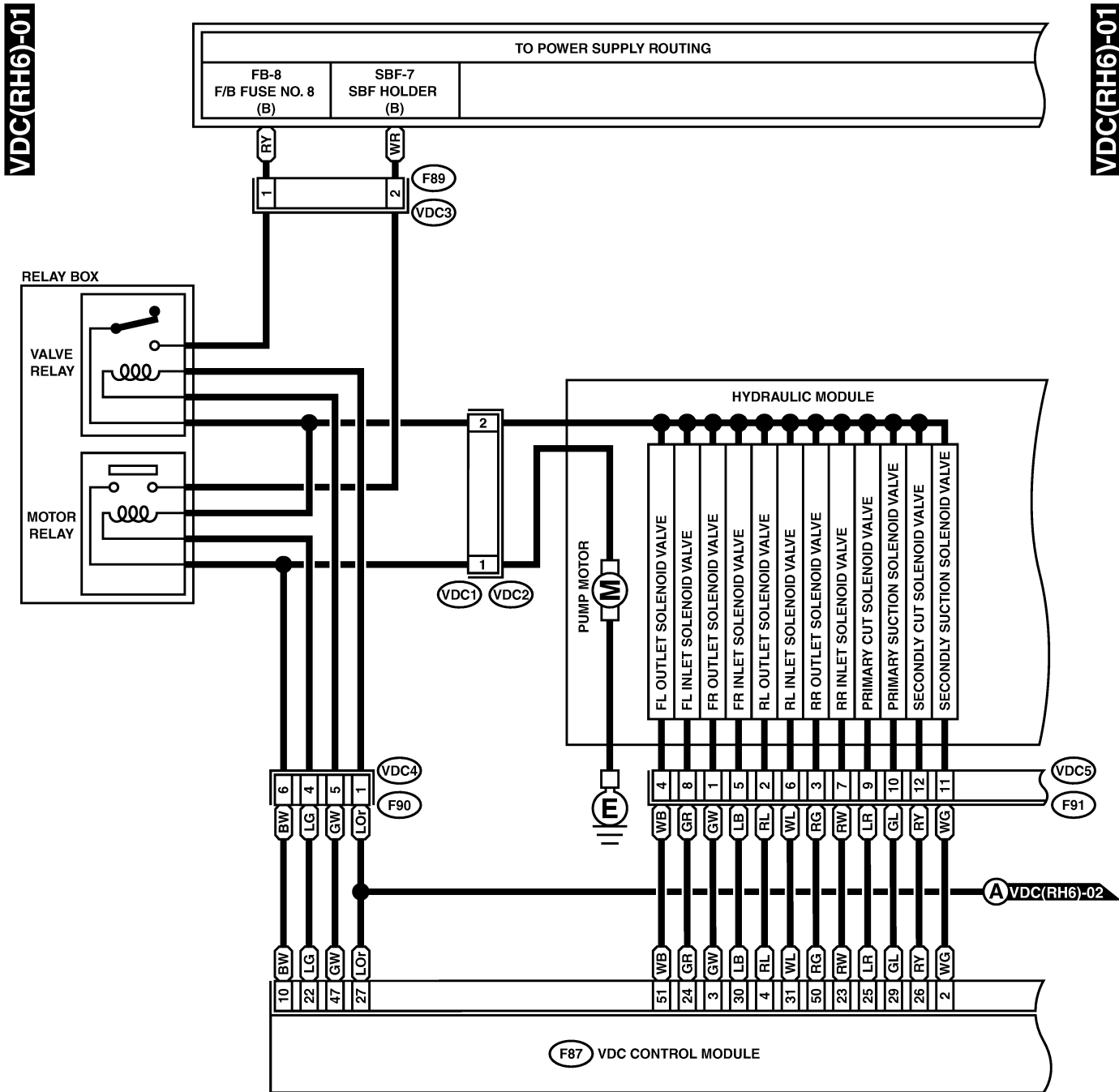

F89 (GRAY)

F90 (BLACK)

F91 (BLACK)

VDC1

1	2	3
4	5	6

4	3	2	1
8	7	6	5
12	11	10	9
16	15	14	13

F87 (BLACK)

1	2	3	4	5	6	7	8	9	10	11	12	13	14	15	16	17	18	19	20	21	22	23	24	25	26	27	28	
29	30	31	32	33	34	35	36	37	38	39	40	41	42	43	44	45	46	47	48	49	50	51	52	53	54	55		
56	57	58	59	60	61	62	63	64	65	66	67	68	69	70	71	72	73	74	75	76	77	78	79	80	81	82	83	

# VEHICLE DYNAMIC CONTROL SYSTEM

Wiring System

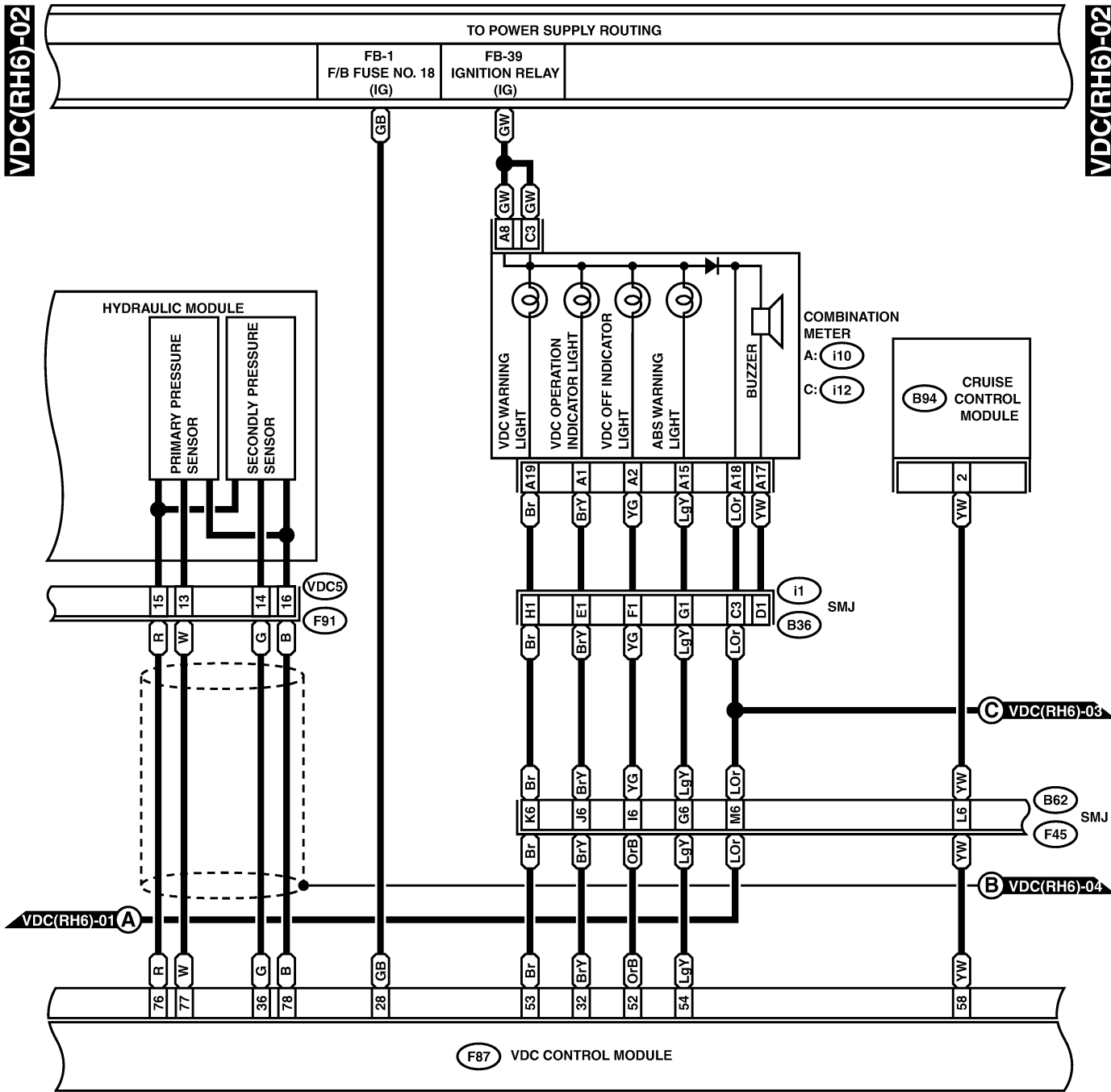

C: i12 (GREEN)

1	2	3	4	5	6
7	8	9	10	11	12
13	14				

F91 (BLACK)

4	3	2	1
8	7	6	5
12	11	10	9
16	15	14	13

B94 (BLACK)

1	2	3	4	5	6	7	8	9	10
11	12	13	14	15	16	17	18	19	20

A: i10 (GREEN)

1	2	3	4	5	6	7	8	9	10	11	12	13	14
15	16	17	18	19	20	21	22	23	24	25	26	27	28
29	30												

F87 (BLACK)

1	2	3	4	5	6	7	8	9	10	11	12	13	14	15	16	17	18	19	20	21	22	23	24	25	26	27	28
29	30	31	32	33	34	35	36	37	38	39	40	41	42	43	44	45	46	47	48	49	50	51	52	53	54	55	56
57	58	59	60	61	62	63	64	65	66	67	68	69	70	71	72	73	74	75	76	77	78	79	80	81	82	83	

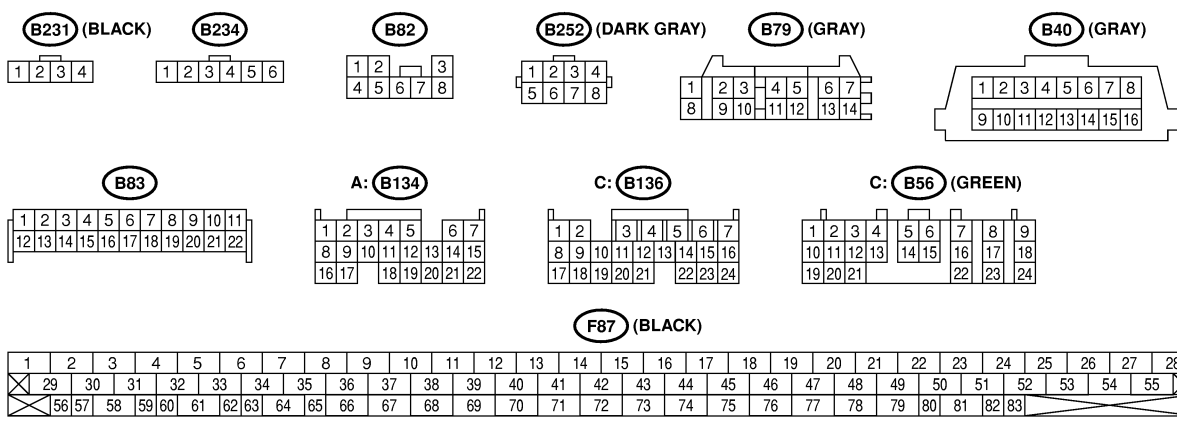
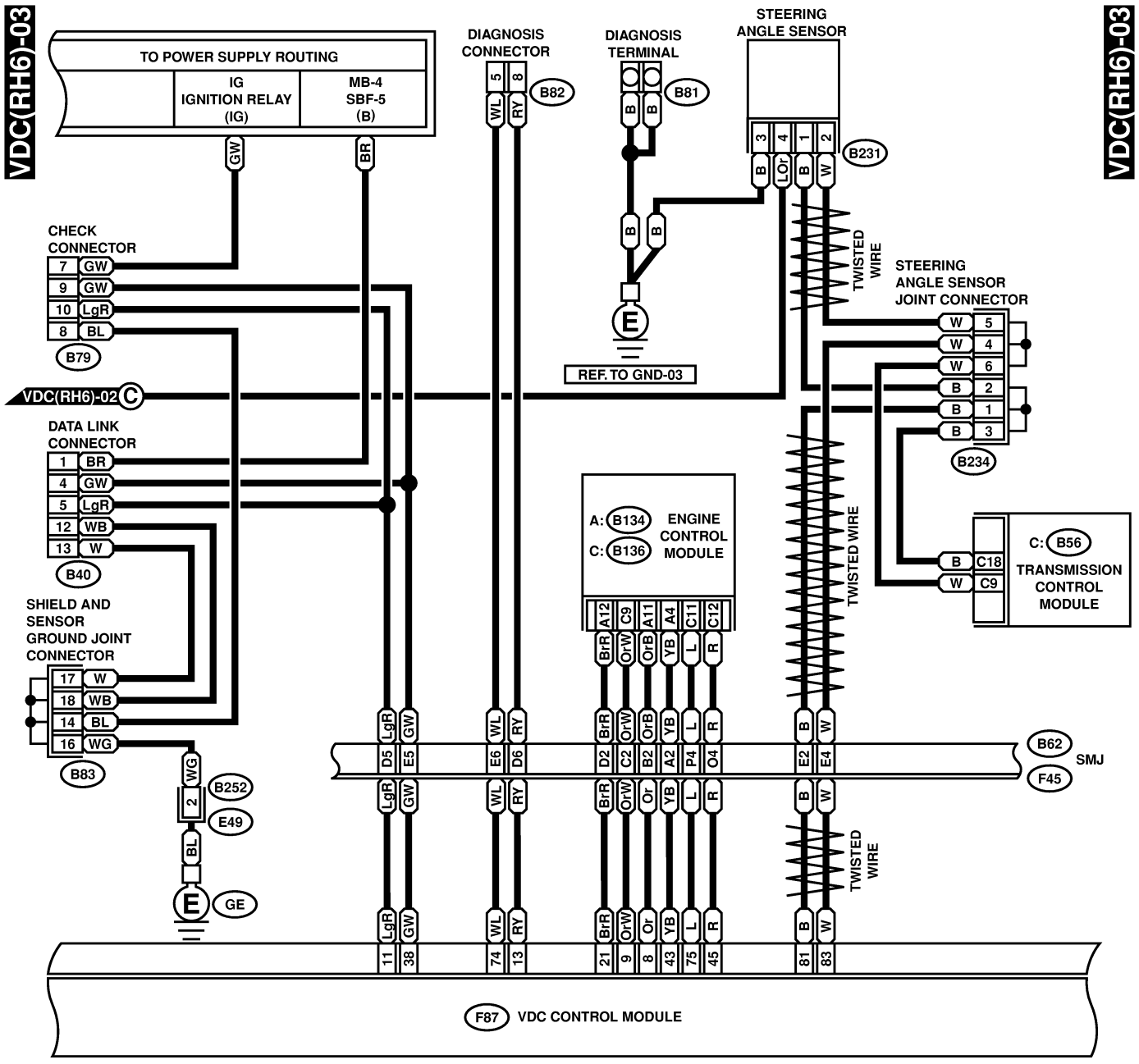

# VEHICLE DYNAMIC CONTROL SYSTEM

Wiring System

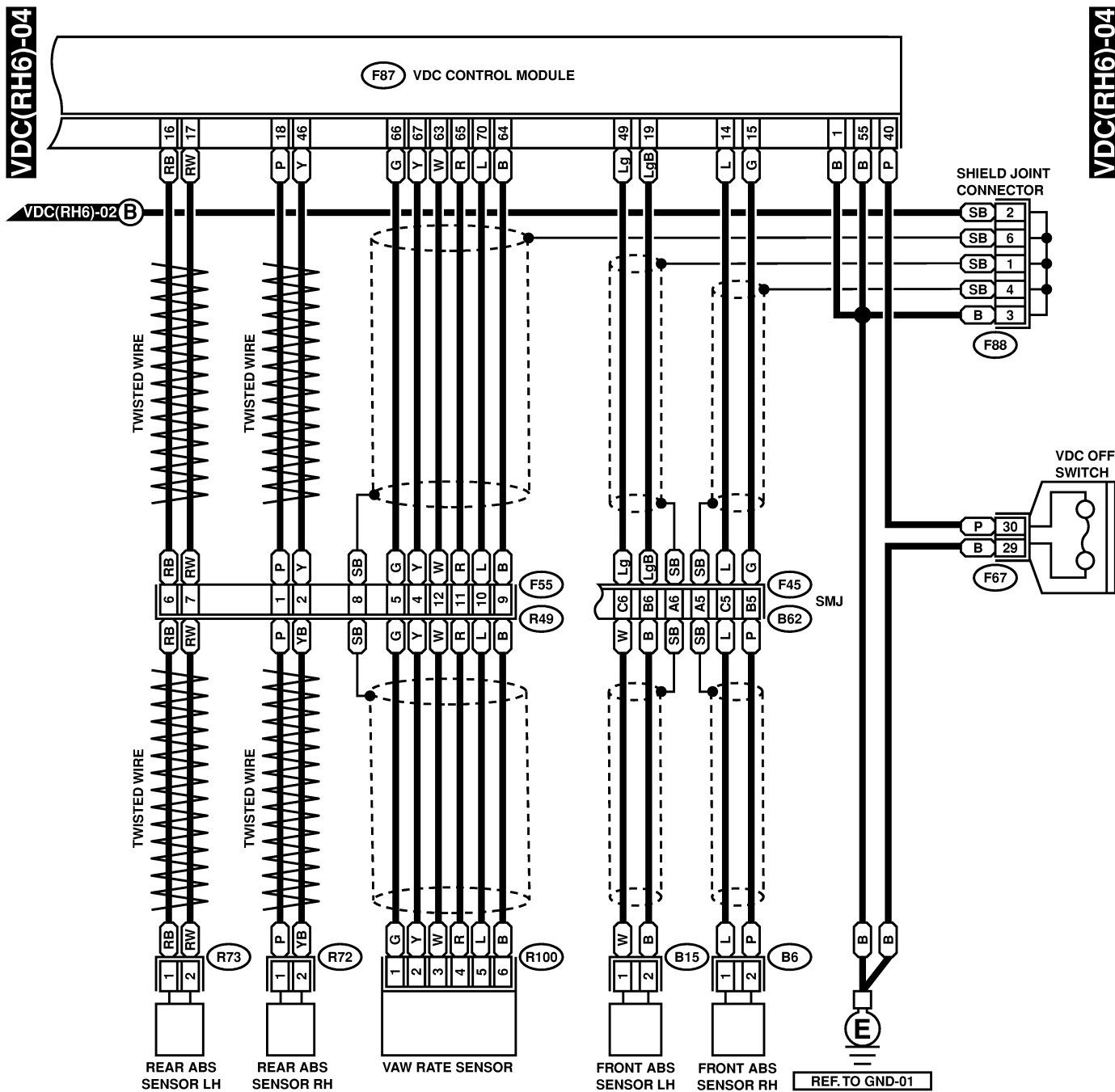

**B6** (GRAY)

**B15** (GRAY)

**R73** (GRAY)

**R72** (GRAY)



**R100**

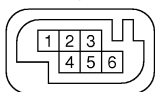

**F88**



**F55**

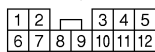

**F67**

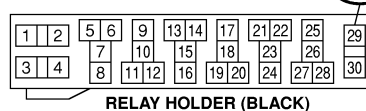

**F87** (BLACK)

1	2	3	4	5	6	7	8	9	10	11	12	13	14	15	16	17	18	19	20	21	22	23	24	25	26	27	28
29	30	31	32	33	34	35	36	37	38	39	40	41	42	43	44	45	46	47	48	49	50	51	52	53	54	55	56
57	58	59	60	61	62	63	64	65	66	67	68	69	70	71	72	73	74	75	76	77	78	79	80	81	82	83	84

## 47. Wiper and Washer System (Front)

S903442

### A: SCHEMATIC

S903442A21

#### 1. LHD MODEL

S903442A2101

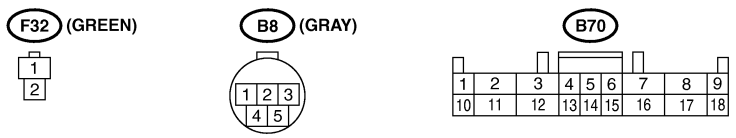
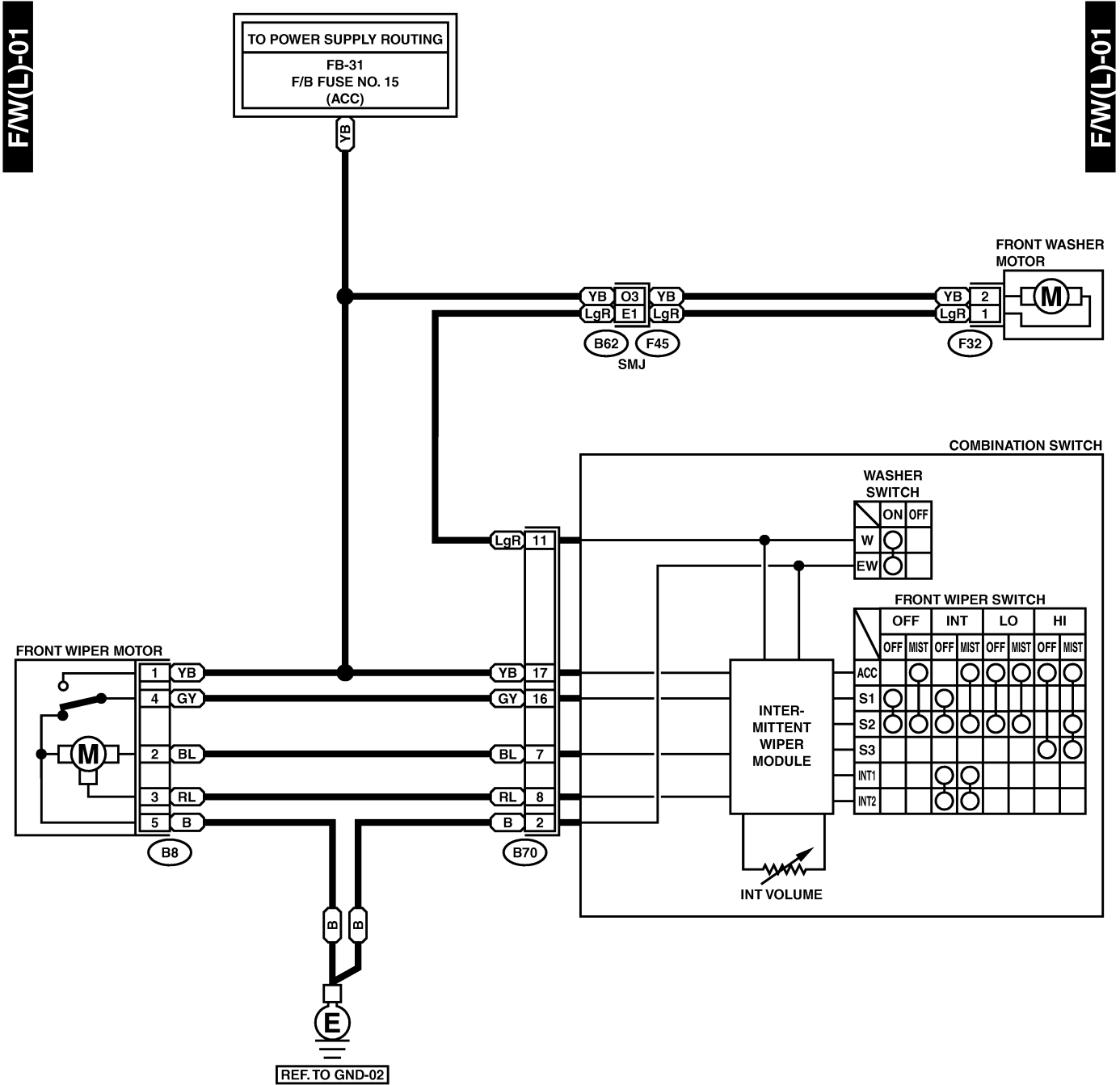

# WIPER AND WASHER SYSTEM (FRONT)

Wiring System

## 2. RHD MODEL S903442A2102

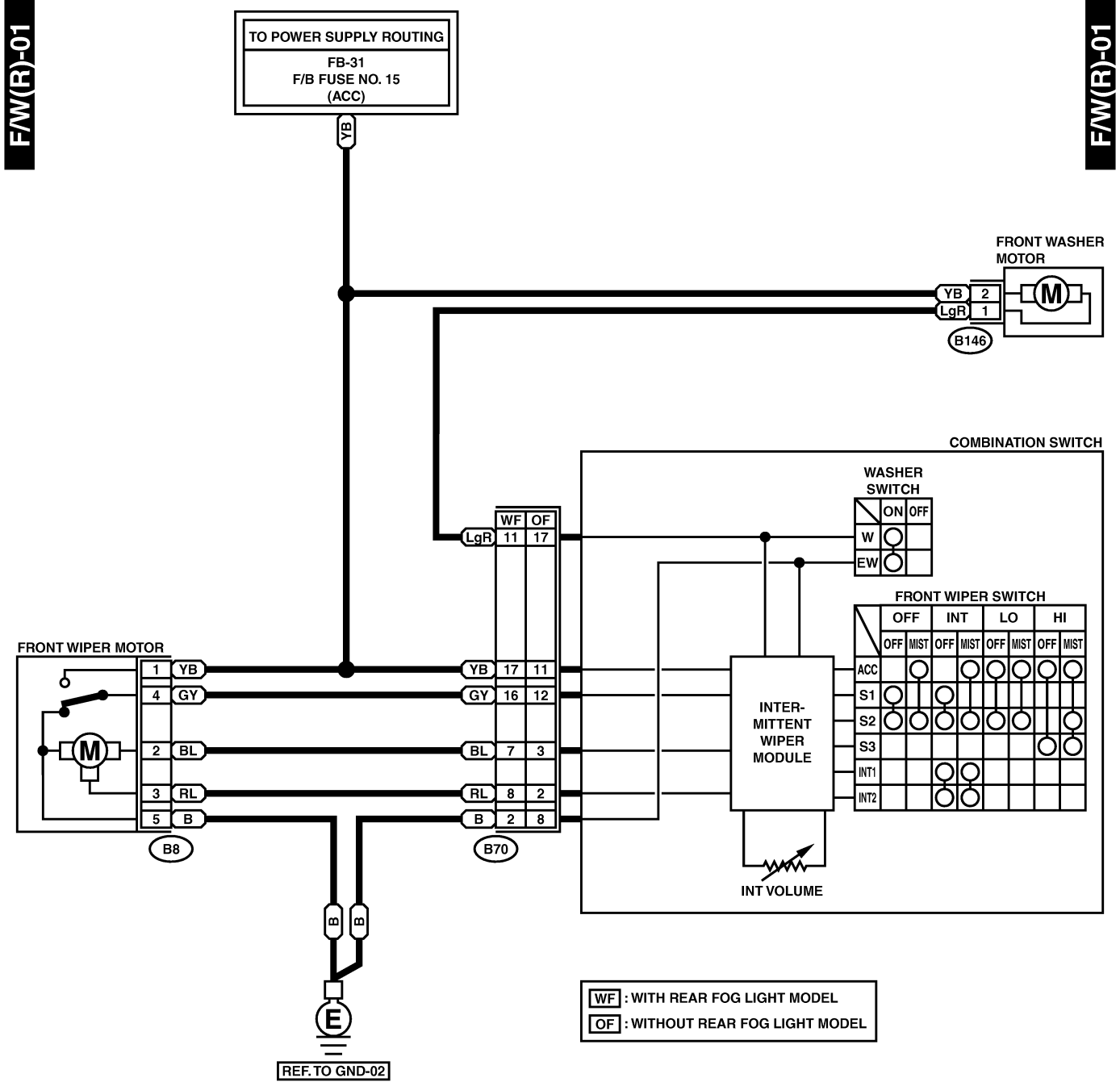

B146 (GREEN)



B8



B70

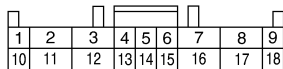

## 48. Wiper and Washer System (Rear)

S903443

### A: SCHEMATIC

S903443A21

#### 1. LHD MODEL

S903443A2101

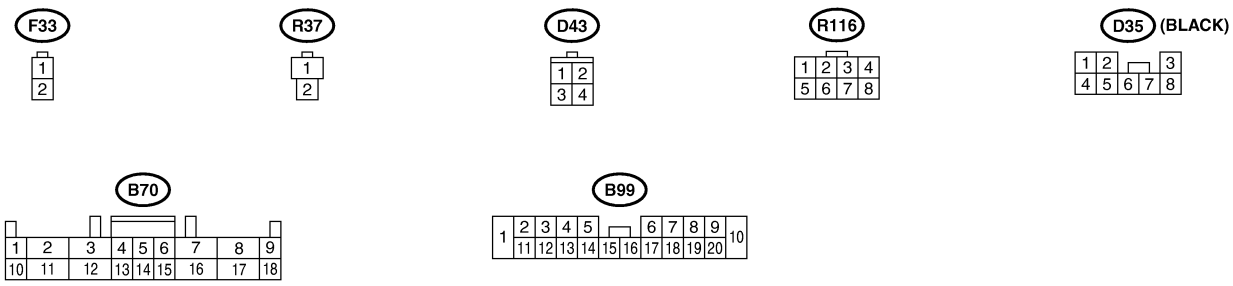
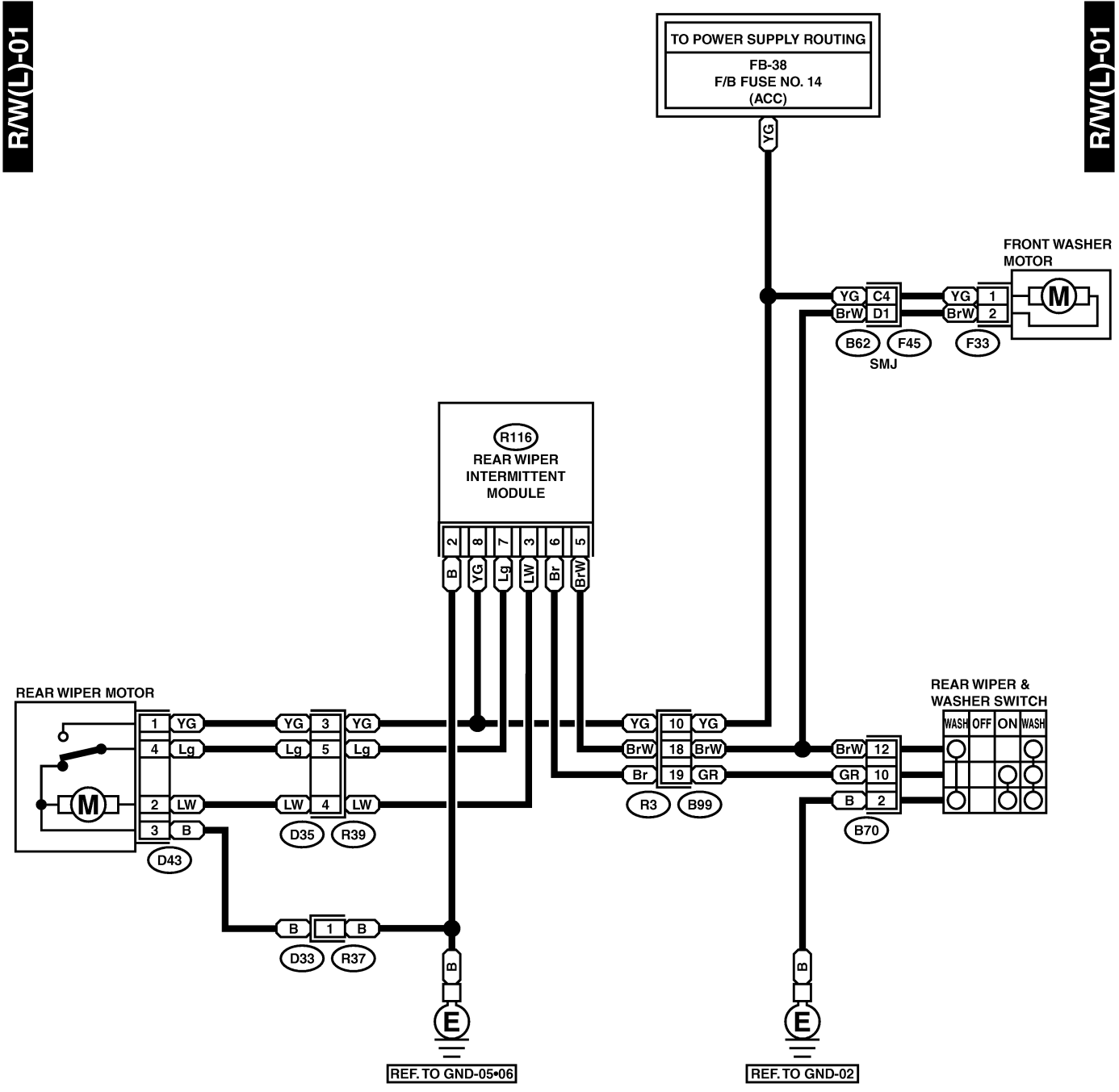



# WIPER AND WASHER SYSTEM (REAR)

Wiring System

## 2. RHD MODEL S903443A2102

R/W(R)-01

R/W(R)-01

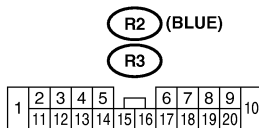
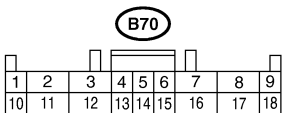
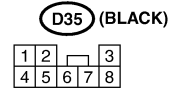
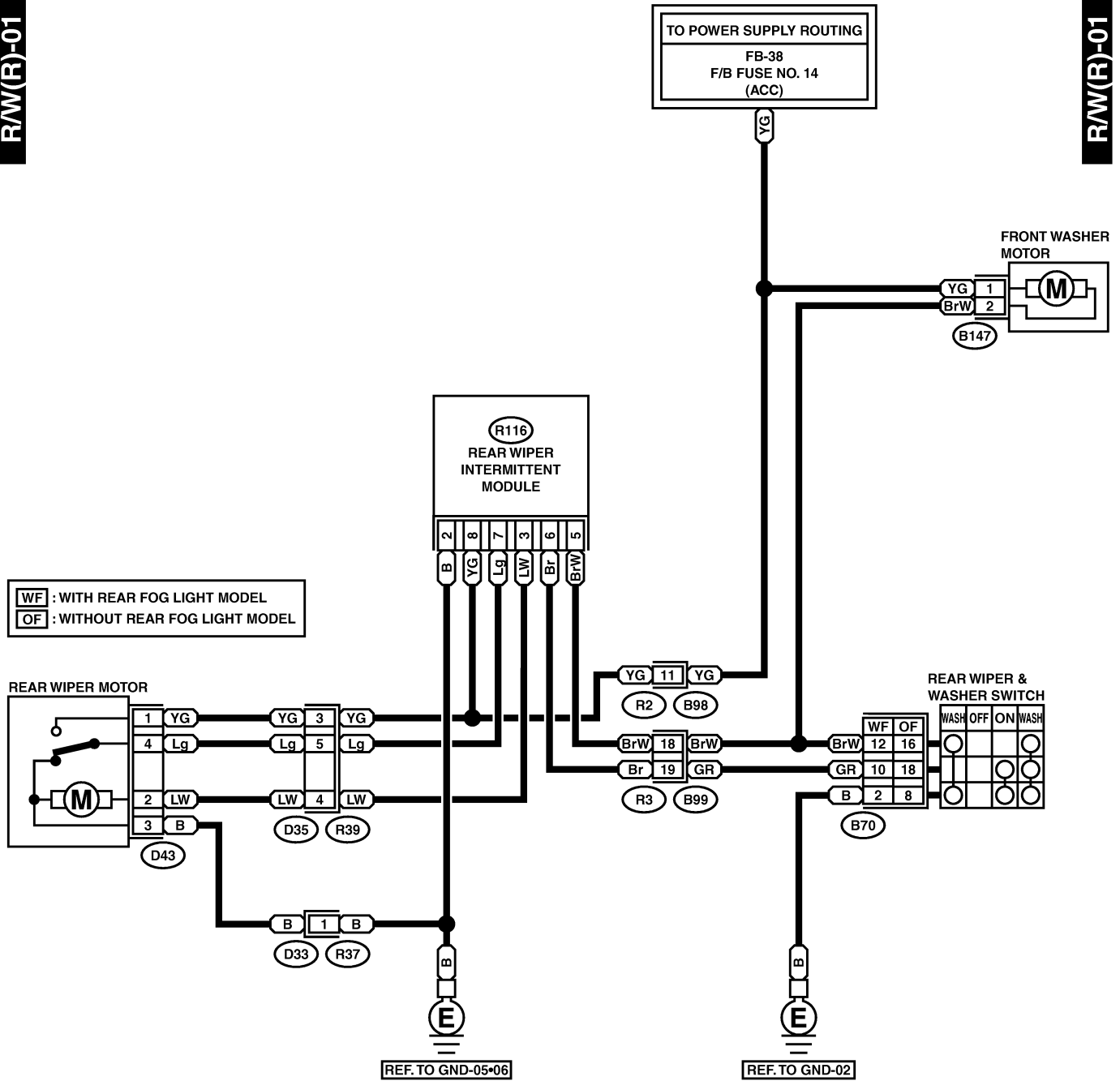

## 49. Wiper Deicer System S903444

### A: SCHEMATIC S903444A21

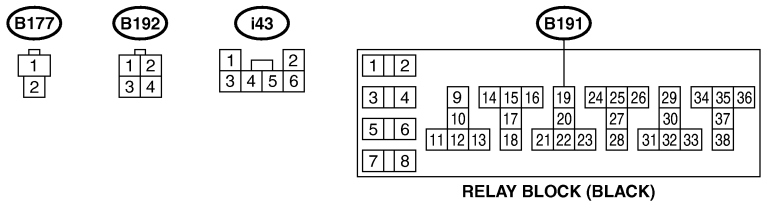
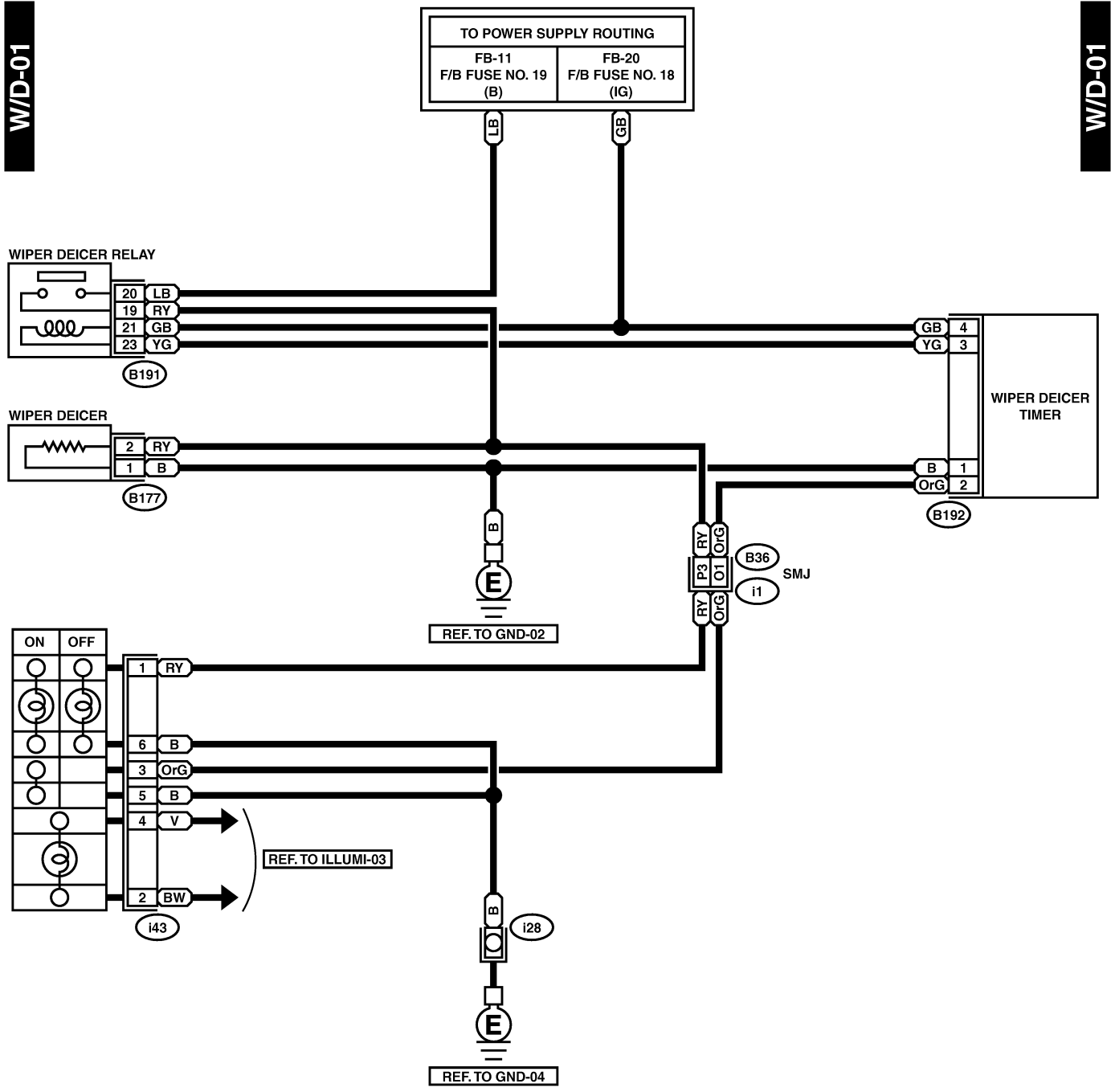

# OVERALL SYSTEMS

Wiring System

## 50. Overall Systems S903672

### A: LOCATION S903672A13

#### 1. LHD SEDAN MODEL S903672A1303

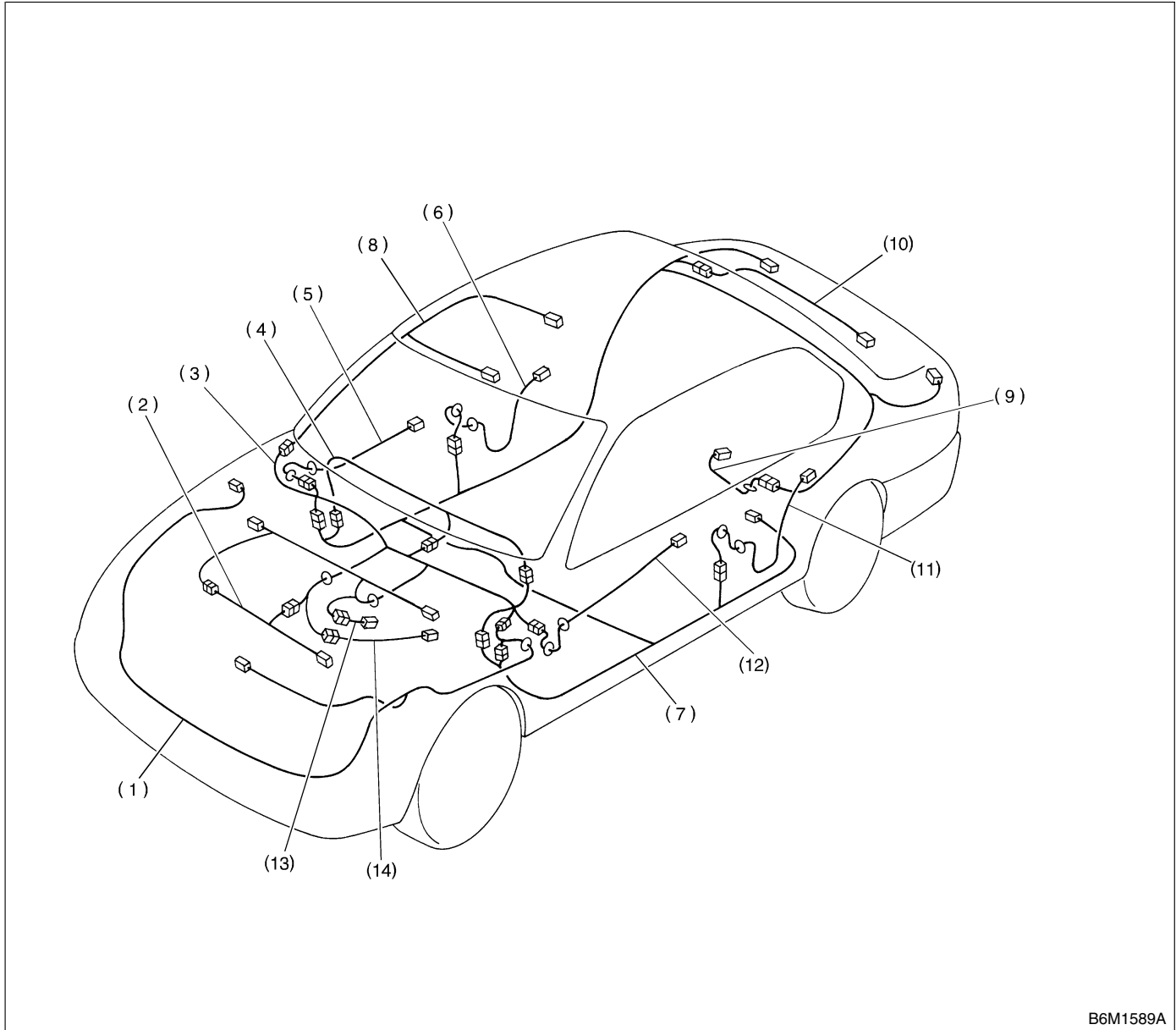

B6M1589A

- |                                     |                         |                              |
|-------------------------------------|-------------------------|------------------------------|
| (1) Front wiring harness            | (6) Rear door cord RH   | (11) Rear door cord LH       |
| (2) Engine wiring harness           | (7) Rear wiring harness | (12) Front door cord LH      |
| (3) Bulkhead wiring harness         | (8) Roof cord           | (13) Transmission cord       |
| (4) Instrument panel wiring harness | (9) Fuel tank cord      | (14) Rear oxygen sensor cord |
| (5) Front door cord RH              | (10) Trunk lid cord     |                              |

## 2. RHD SEDAN MODEL S903672A1304

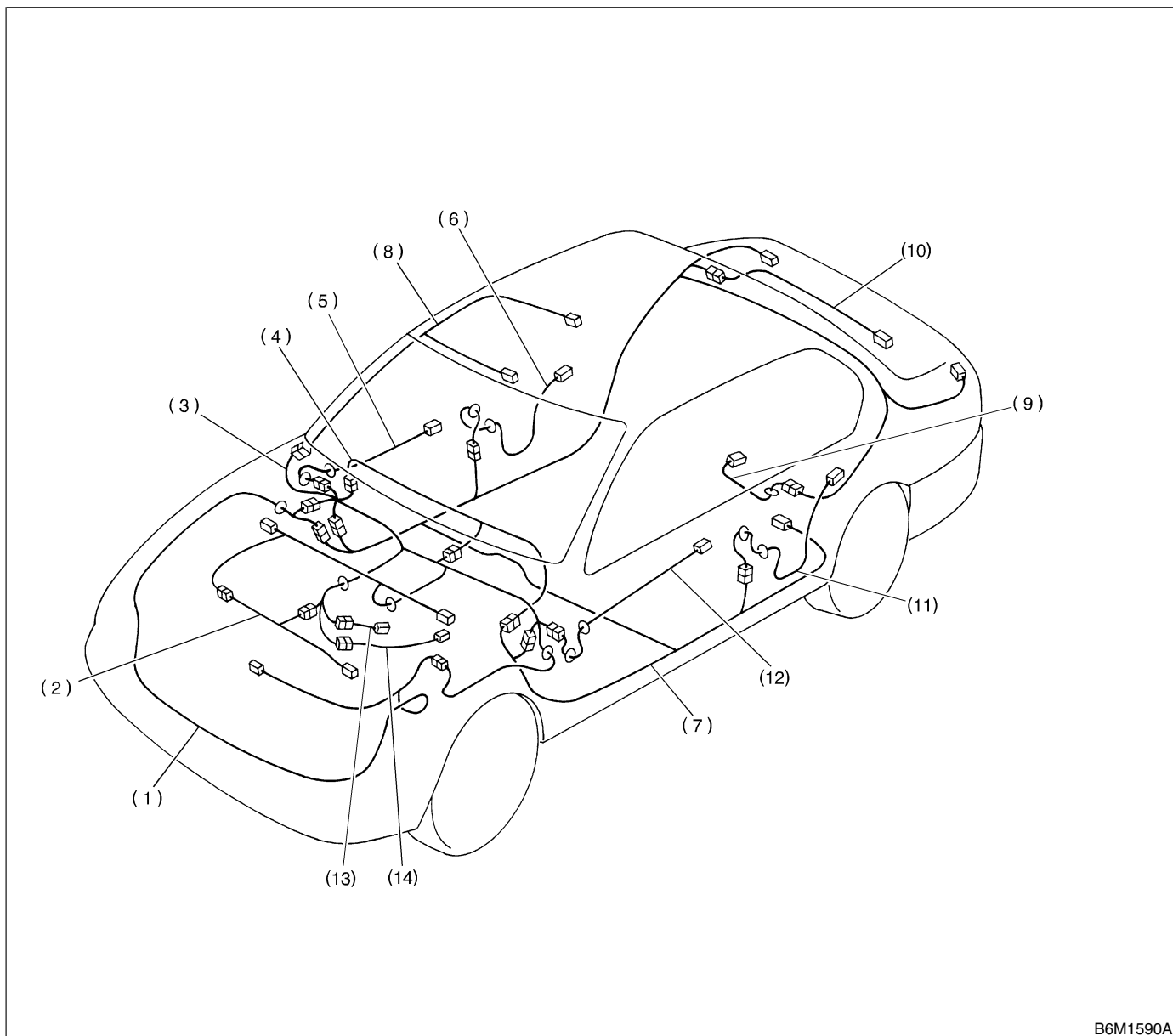

B6M1590A

- |                                     |                         |                              |
|-------------------------------------|-------------------------|------------------------------|
| (1) Front wiring harness            | (6) Rear door cord RH   | (11) Rear door cord LH       |
| (2) Engine wiring harness           | (7) Rear wiring harness | (12) Front door cord LH      |
| (3) Bulkhead wiring harness         | (8) Roof cord           | (13) Transmission cord       |
| (4) Instrument panel wiring harness | (9) Fuel tank cord      | (14) Rear oxygen sensor cord |
| (5) Front door cord RH              | (10) Trunk lid cord     |                              |

# OVERALL SYSTEMS

Wiring System

## 3. LHD WAGON MODEL S903672A1305

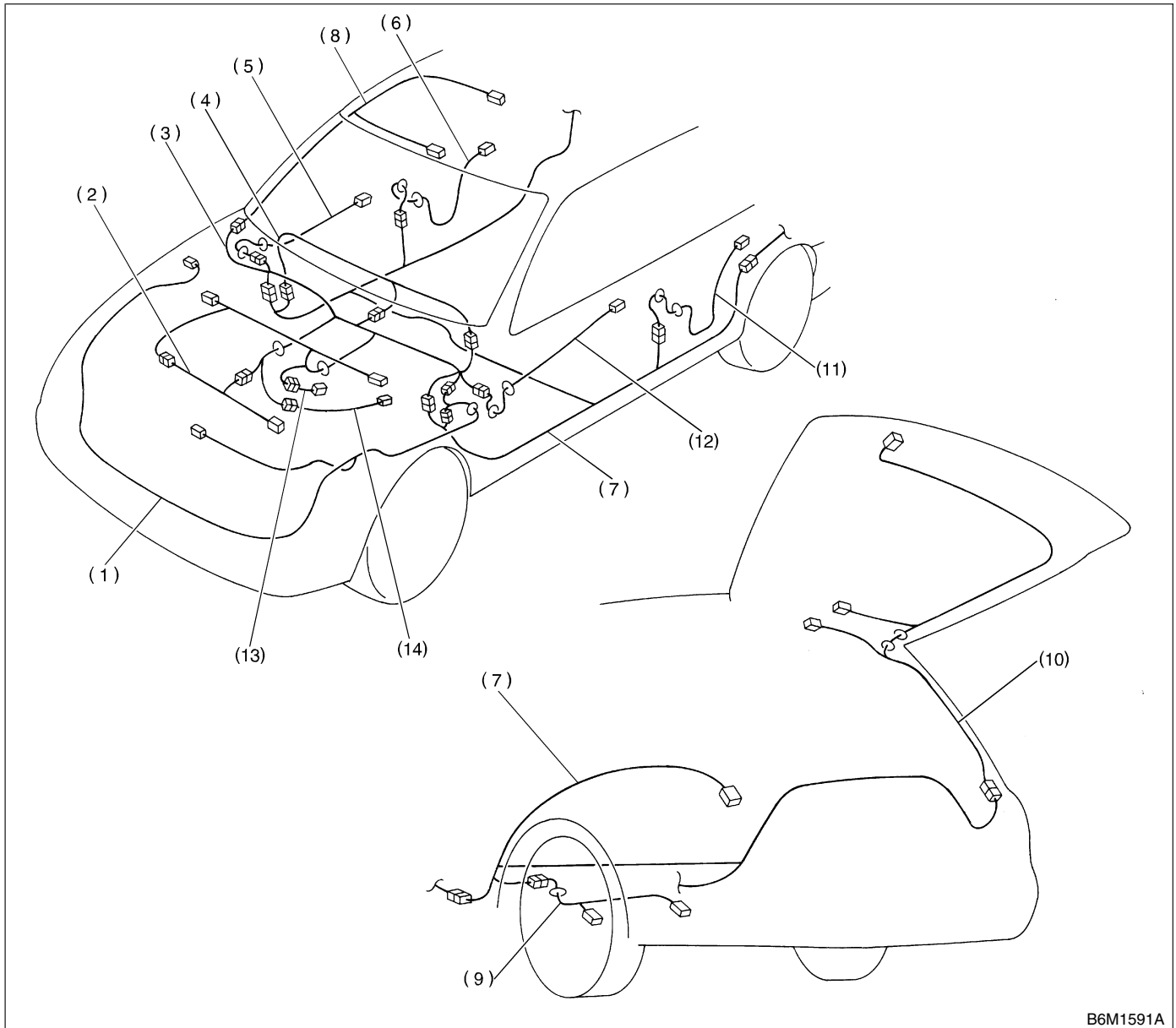

B6M1591A

- |                                     |                         |                              |
|-------------------------------------|-------------------------|------------------------------|
| (1) Front wiring harness            | (6) Rear door cord RH   | (11) Rear door cord LH       |
| (2) Engine wiring harness           | (7) Rear wiring harness | (12) Front door cord LH      |
| (3) Bulkhead wiring harness         | (8) Roof cord           | (13) Transmission cord       |
| (4) Instrument panel wiring harness | (9) Fuel tank cord      | (14) Rear oxygen sensor cord |
| (5) Front door cord RH              | (10) Rear gate cord     |                              |

## 4. RHD WAGON MODEL S903672A1306

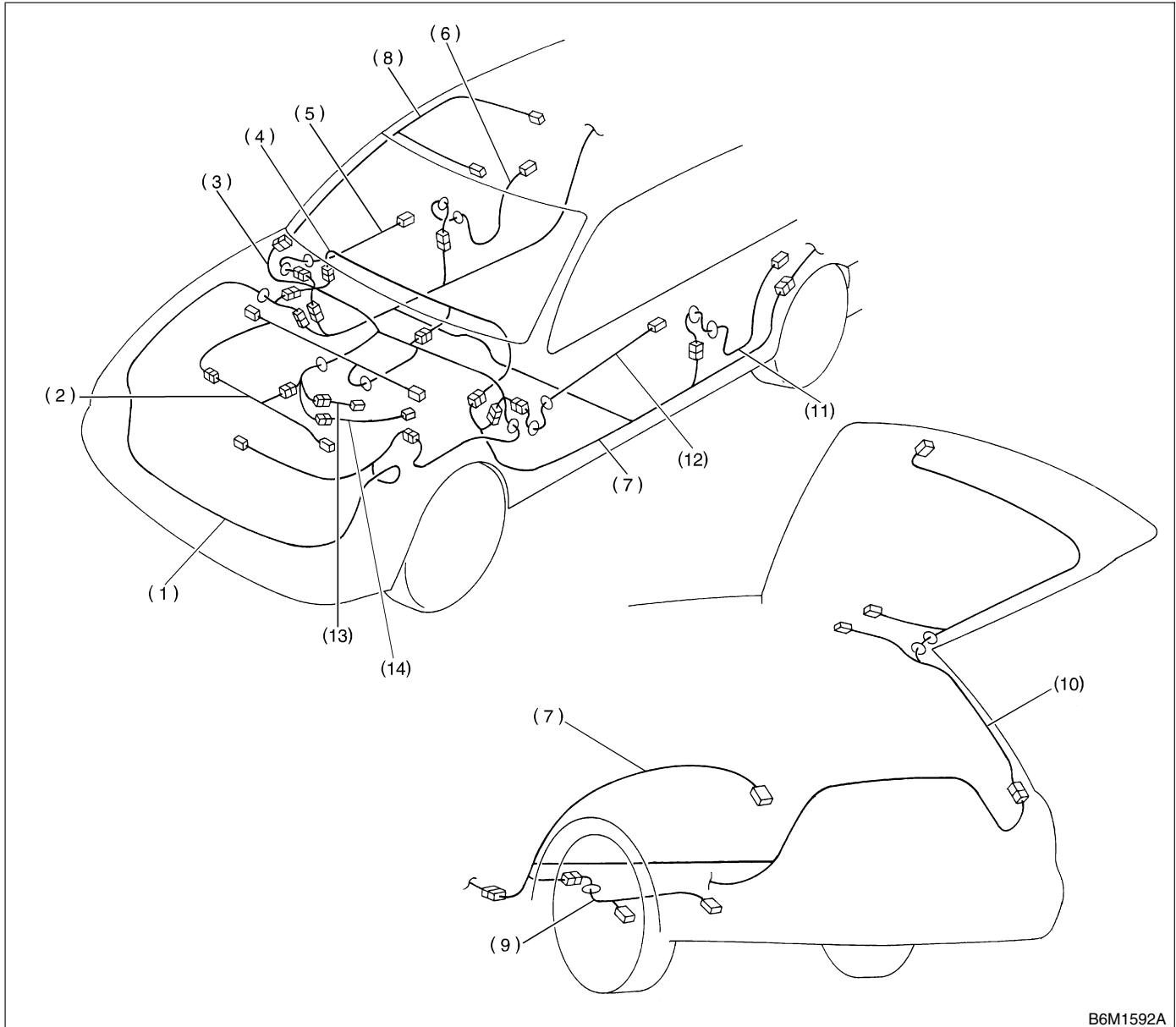

B6M1592A

- |                                     |                         |                              |
|-------------------------------------|-------------------------|------------------------------|
| (1) Front wiring harness            | (6) Rear door cord RH   | (11) Rear door cord LH       |
| (2) Engine wiring harness           | (7) Rear wiring harness | (12) Front door cord LH      |
| (3) Bulkhead wiring harness         | (8) Roof cord           | (13) Transmission cord       |
| (4) Instrument panel wiring harness | (9) Fuel tank cord      | (14) Rear oxygen sensor cord |
| (5) Front door cord RH              | (10) Rear gate cord     |                              |

# FRONT WIRING HARNESS

Wiring System

## 51. Front Wiring Harness S903445

### A: LOCATION S903445A13

#### 1. LHD MODEL S903445A1302

Connector				Connecting to	
No.	Pole	Color	Area	No.	Name
F3	2	Gray	B-1		Front turn signal light RH
F4	2	Blue	B-1		Front clearance light RH
F5	1	Black	C-1		Horn
F6	2	Blue	C-1		Front fog light RH
F7	3	Gray	C-1		Headlight RH
F16	2	Black	C-1		Sub fan motor (4-cylinder engine model)
	4	Gray	C-1		Sub fan motor (6-cylinder engine model)
F17	2	Black	C-2		Radiator main fan motor (4-cylinder engine model)
	4	Gray	C-2		Radiator main fan motor (6-cylinder engine model)
F19	2	Gray	C-3		Front turn signal light LH
F21	2	Blue	D-3		Front fog light LH
F22	2	Blue	C-3		Front clearance light LH
F23	3	Gray	C-2		Headlight LH
F25	1	★	C-2		Generator
F26	3	Green	C-2		
F27	4	Black	A-3		A/C fuse (Relay holder)
F28	4	Black	A-3		A/C sub fan relay (Relay holder-4 cylinder engine model)
	4	Black	A-4		A/C sub fan relay-1 (Relay holder-6 cylinder engine model)
F29	4	Black	A-4		A/C sub fan relay-2 (Relay holder-6 cylinder engine model)
F30	4	Black	A-3		Radiator main fan relay-2 (Relay holder-6 cylinder engine model)
F28	4	Black	A-3		A/C sub fan relay (Relay holder)
F31	4	Black	A-3		A/C relay (Relay holder)
F32	2	Green	B-3		Front washer motor
F33	2	★	B-3		Rear washer motor
F34	4	Black	C-3		SBF holder

Connector				Connecting to	
No.	Pole	Color	Area	No.	Name
F35	2	Black	B-4		M/B
F36	3	★	C-4		
F37	6	Black	C-4		
F38	1	★	C-4		
F39	8	Black	B-3		F/B
F40	9	Brown	C-4		
F41	7	Gray	B-4		
F44	8	★	B-4	B61	Bulkhead wiring harness
F45	66	Gray	B-3	B62	Bulkhead wiring harness (SMJ)
F46	4	★	B-4	B108	Bulkhead wiring harness (6-cylinder engine model)
F47	1	Black	C-2		Horn
F49	31	Black	B-2		ABS control module
F51	2	Black	B-2		Side turn signal light RH
F54	2	Black	B-4		Side turn signal light LH
F55	12	★	B-4	R49	Rear wiring harness
F58	3	Gray	D-2		Headlight leveler LH
F59	3	Gray	C-1		Headlight leveler RH
F62	3	Gray	B-1	F63	Shield joint connector (ABS)
F63	3	Gray	B-1	F62	
F65	4	Black	A-4		Front fog light relay (Relay holder)
F66	4	Black	A-3		Radiator main fan relay (Relay holder-4-cylinder engine model)
	4	Black	A-3		Radiator main fan relay-1 (Relay holder-6-cylinder engine model)
F67	2	Black	A-4		FWD switch (Relay holder-without VDC model)
	2	Black	A-4		VDC off switch (Relay holder with VDC model)
F66	4	Black	A-3		Radiator main fan relay (Relay holder)
F67	2	Black	A-4		FWD switch (Relay holder)
F68	4	Black	C-4		M/B
F73	1	★	B-2		ABS motor ground
F78	2	Black	C-2		Ambient sensor

# FRONT WIRING HARNESS

Wiring System

Connector				Connecting to	
No.	Pole	Color	Area	No.	Name
F82	1	Black	C-2		A/C magnet clutch (4-cylinder engine model)
	3	Black	C-2		A/C magnet clutch (6-cylinder engine model)
F87	83	Black	B-4		VDC module
F88	6	★	B-4		Shield joint connec- tor (VDC)
F89	2	Gray	B-1		Relay box (VDC)
F90	6	Black	B-2		
F91	16	Black	B-2		Hydraulic module (VDC)
F92	4	Gray	C-3		A/S compressor & discharge solenoid
F93	8	Gray	C-3		A/S solenoid
★: Non-colored					



# FRONT WIRING HARNESS

Wiring System

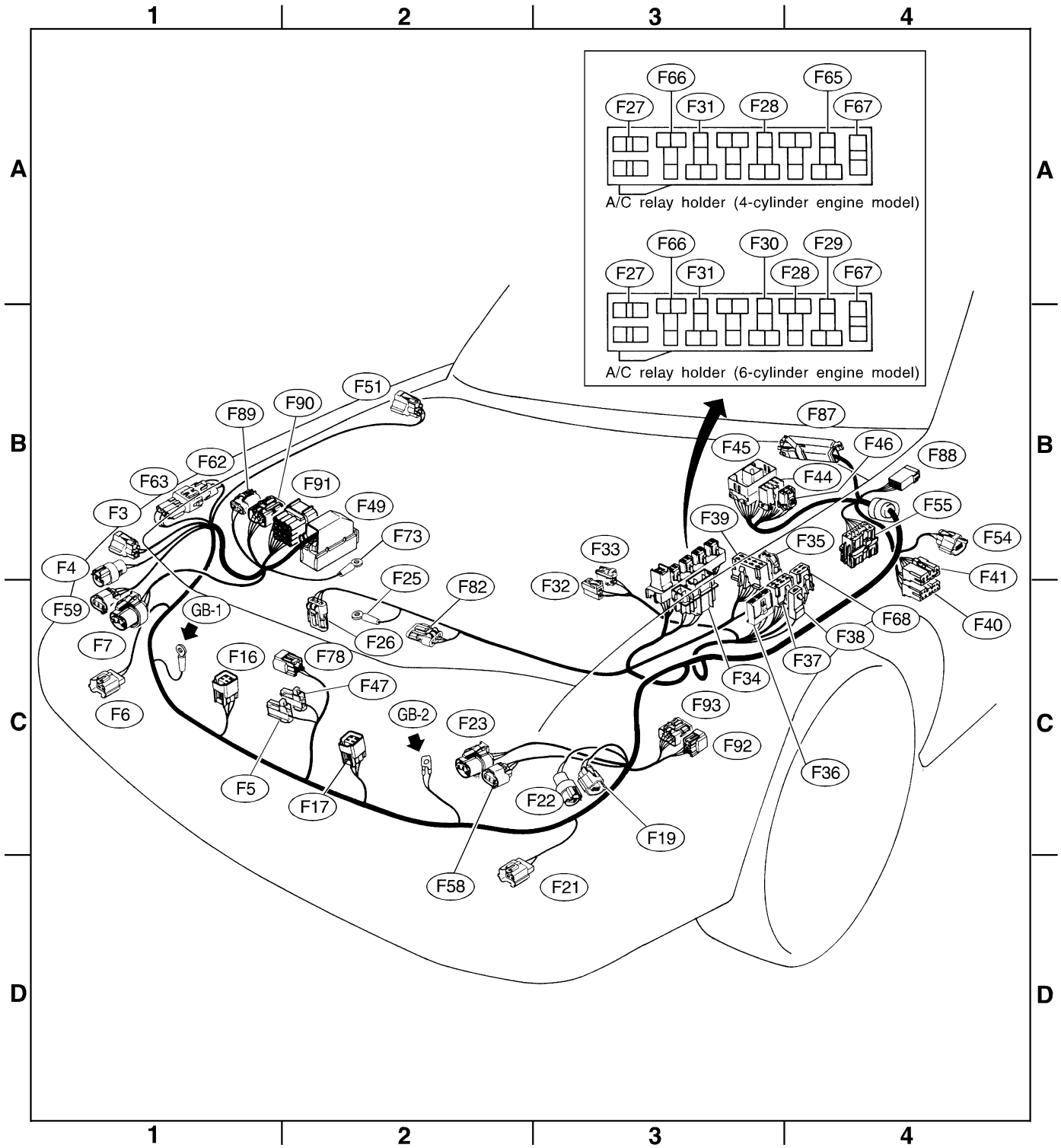

B6M1593A

# FRONT WIRING HARNESS

Wiring System

## 2. RHD MODEL S903445A1303

Connector				Connecting to	
No.	Pole	Color	Area	No.	Name
F3	2	Gray	B-1		Front turn signal light RH
F4	2	Blue	B-1		Front clearance light RH
F5	1	Black	C-2		Horn
F6	2	Blue	C-1		Front fog light RH
F7	3	Gray	C-1		Headlight RH
F16	2	Black	C-1		Sub fan motor (4-cylinder engine model)
	4	Gray	C-1		Sub fan motor (6-cylinder engine model)
F17	2	Black	C-2		Radiator main fan motor (4-cylinder engine model)
	4	Gray	C-2		Radiator main fan motor (6-cylinder engine model)
F19	2	Gray	C-3		Front turn signal light LH
F21	2	Blue	D-2		Front fog light LH
F22	2	Blue	C-3		Front clearance light LH
F23	3	Gray	C-2		Headlight LH
F25	1	★	C-2		Generator
F26	3	Green	C-2		
F27	4	Black	A-3		A/C fuse (Relay holder)
F28	4	Black	A-4		A/C sub fan relay (Relay holder-4-cylinder engine model)
	4	Black	A-4		A/C sub fan relay-1 (Relay holder-6-cylinder engine model)
F29	4	Black	A-4		A/C sub fan relay-2 (Relay holder-6-cylinder engine model)
F30	4	Black	A-4		Radiator main fan relay-2 (Relay holder-6-cylinder engine model)
F66	4	Black	A-3		Radiator main fan relay (Relay holder-4-cylinder engine model)
	4	Black	A-3		Radiator main fan relay-1 (Relay holder-6-cylinder engine model)
F28	4	Black	A-4		A/C sub fan relay (Relay holder)
F31	4	Black	A-3		A/C relay (Relay holder)
F34	4	Black	C-3		SBF holder
F35	2	Black	B-4		
F39	8	Black	B-3		M/B
F41	7	Gray	B-2		F/B
F44	6	★	B-3	B61	Bulkhead wiring harness
F45	66	Gray	B-3	B62	Bulkhead wiring harness (SMJ)
F47	1	Black	C-2		Horn
F49	31	Black	B-2		ABS control module
F51	2	Black	B-2		Side turn signal light RH
F55	12	★	B-2	R49	Rear wiring harness
F58	3	Gray	C-2		Headlight leveler LH
F59	3	Gray	C-1		Headlight leveler RH
F62	3	Gray	B-1	F63	Shield joint connector (ABS)
F63	3	Gray	B-1	F62	
F65	4	Black	A-4		Front fog light relay (Relay holder)
F66	4	Black	A-3		Radiator main fan relay (Relay holder-4-cylinder engine model)
	4	Black	A-3		Radiator main fan relay-1 (Relay holder-6-cylinder engine model)
F67	2	Black	A-4		FWD switch (Relay holder-without VDC model)
	2	Black	A-4		VDC off switch (Relay holder-with VDC model)
F73	1	★	B-2		ABS motor ground
F78	2	Black	C-2		Ambient sensor

# FRONT WIRING HARNESS

Wiring System

Connector				Connecting to	
No.	Pole	Color	Area	No.	Name
F79	2	Gray	C-2		A/C pressure switch (4-cylinder engine model)
	4	★	C-2		A/C pressure switch (6-cylinder engine model)
F82	1	Black	C-2		A/C magnet clutch
F83	2	Blue	C-2		Thermal protector (4-cylinder engine model)
	4	★	C-2		Thermal protector (6-cylinder engine model)
F86	1	Gray	C-3	B212	Bulkhead wiring harness
F87	83	Black	B-2		VDC module
F88	6	★	B-2		Shield joint connector (VDC)
F89	2	Gray	B-1		Relay box (VDC)
F90	6	Black	B-1		
F91	16	Black	B-2		Hydraulic module (VDC)

★: Non-colored

# FRONT WIRING HARNESS

Wiring System

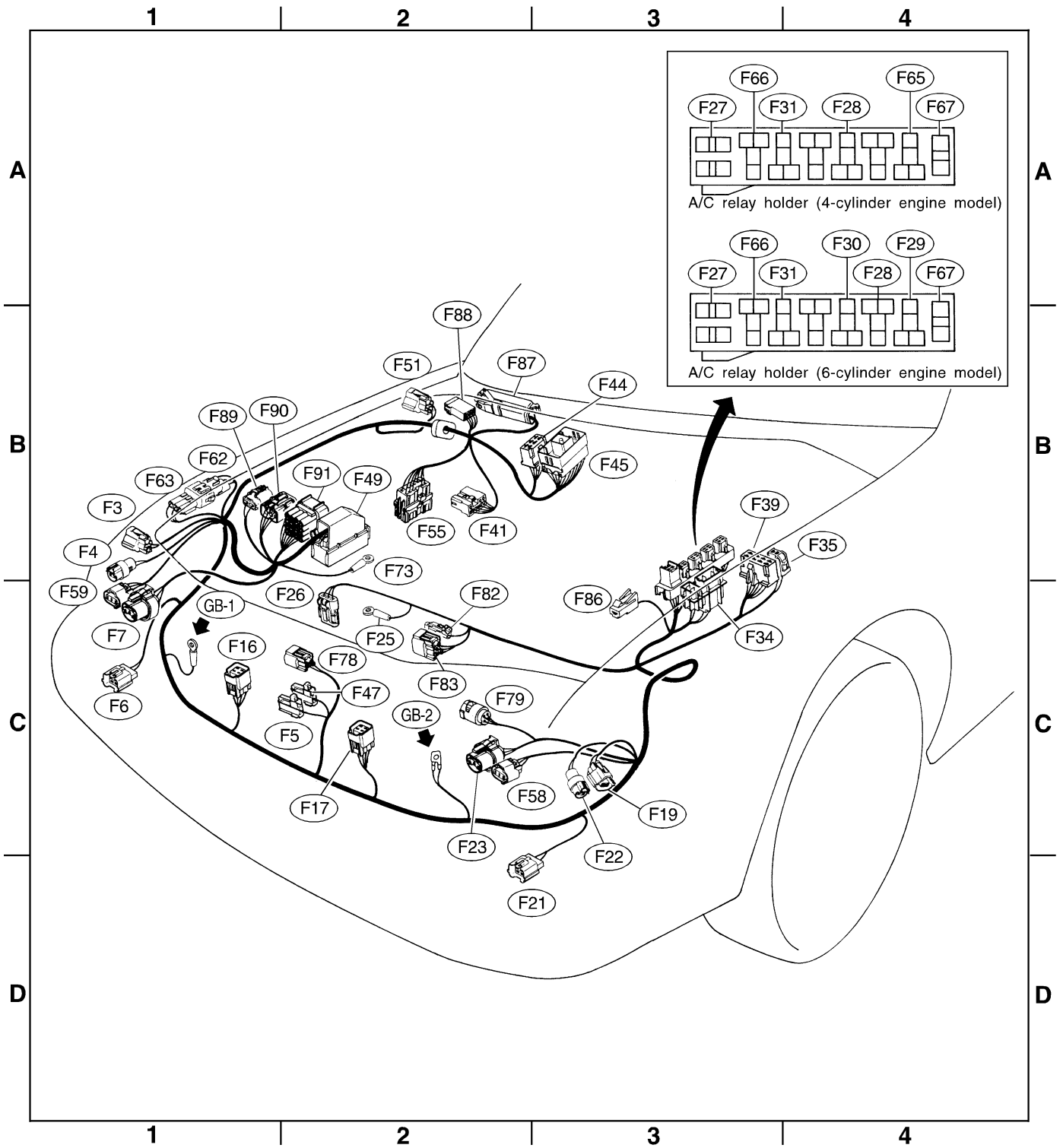

B6M1594A